



Filing Receipt

Received - 2022-05-10 11:36:48 AM

Control Number - 53330

ItemNumber - 6

PUC DOCKET NO. 53330

PETITION BY DENTON OLIVER CREEK, LP	§	BEFORE THE
FOR EXPEDITED RELEASE FROM	§	
SEWER CCN NO. 21059	§	PUBLIC UTILITY COMMISSION
HELD BY AQUA TEXAS, INC.	§	
IN DENTON COUNTY	§	OF TEXAS

**FIRST AMENDED PETITION BY DENTON OLIVER CREEK, LP FOR EXPEDITED
RELEASE PURSUANT TO TEXAS WATER CODE SECTION 13.2541**

TO THE PUBLIC UTILITY COMMISSION OF TEXAS:

Denton Oliver Creek, LP (“Petitioner”) files its First Amended Petition with the Public Utility Commission of Texas (the “PUC”) for expedited release from Aqua Texas, Inc.’s (“Aqua”) sewer certificate of convenience and necessity (“CCN”) No. 21059 pursuant to (i) Texas Water Code Section 13.2541; and (ii) 16 Texas Administrative Code Section 24.245, and in support shows as follows:

I. APPLICABLE REGULATIONS

Section 13.2541 of the Texas Water Code provides that the owner of a tract of land that is at least 25 acres and that is not receiving water or sewer service may petition for expedited release of the area from a CCN. *See* TEX. WATER CODE § 13.2541. For land that is located within a county with a population of at least one million, or a county adjacent to a county with a population of at least one million, the owner of the qualifying tract “is entitled to that release.” *Id.* The rule adopted by the PUC pursuant to Section 13.2541 provides the same, and it recognizes that Denton County is a county in which owners of at least 25 acres are entitled to expedited release. *See* 16 TEX. ADMIN. CODE § 24.245(h). Under Section 13.2541(c), the PUC “shall grant a petition not later than the 60th day after the date the landowner files the petition.” *See* TEX. WATER CODE § 13.2541(c).

II. REQUEST FOR EXPEDITED RELEASE

Petitioner owns approximately 570.976 acres of contiguous property in Denton County (the "Property"). The Property is within the boundaries of sewer CCN No. 21059, held by Aqua. Petitioner seeks a partial expedited release from sewer CCN. No. 21059 (the "Requested Area"). An Affidavit in support of this Petition is attached hereto as Exhibit "A." Exhibits "B" and "C" attached to this Petition are true and correct copies of a general location and detailed map of the Property. Petitioner is owner of this land as evidenced by the Special Warranty Deed, attached as Exhibit "D." Exhibit "E" attached to this Petition is a true and correct copy of the ALTA survey for the Property. Digital mapping of the Property has been previously submitted in this docket.

III. CONCLUSION AND PRAYER

Texas Water Code Section 13.2541 entitles Petitioner to expedited release of the Requested Area described herein. The Property is greater than 25 acres, is not receiving sewer service, and are entirely within Denton County. Under Section 13.2541, the PUC should grant this Petition no later than the 60th day after the date of filing. Petitioner respectfully requests that the PUC grant this Petition and issue an order under the authority of Section 13.2541 releasing all portions of the Requested Area that are within the boundaries of Sewer CCN No. 21059.

Respectfully submitted,

COATS | ROSE

By: 

Natalie B. Scott
State Bar No. 24027970
nscott@coatsrose.com
Terrace 2
2700 Via Fortuna, Suite 350
Austin, Texas 78746

(512) 469-7987 Telephone
(512) 469-9408 Telecopier

ATTORNEY FOR PETITIONER

CERTIFICATE OF SERVICE

I hereby certify that on this 10th day of May, 2022, a true and correct copy of the Petition by Denton Oliver Creek, LP for Expedited Release Pursuant to Texas Water Code Section 13.254(a-5) was sent, via certified mail, return receipt requested to the following recipients at the address indicated:

Aqua Texas, Inc.
1106 Clayton Lane
Austin, Texas 78723-3489

Via Certified Mail, RRR

Attorney for PUC:

Scott Miles
1701 N. Congress Avenue
P.O. Box 13326
Austin, Texas 78711-3326
Email: scott.miles@puc.texas.gov



Natalie B. Scott

EXHIBIT "A"

Affidavit of Justin Bono

PETITION BY DENTON OLIVER CREEK, LP	§	BEFORE THE
FOR EXPEDITED RELEASE FROM	§	
SEWER CCN NO. 21059	§	PUBLIC UTILITY COMMISSION
HELD BY AQUA TEXAS, INC.	§	
IN DENTON COUNTY	§	OF TEXAS

AFFIDAVIT OF JUSTIN BONO IN SUPPORT OF FIRST AMENDED PETITION FOR EXPEDITED RELEASE FROM SEWER CCN NO. 21059 HELD BY AQUA TEXAS, INC. PURSUANT TO TEXAS CODE SECTION 13.2541

STATE OF TEXAS §

COUNTY OF DENTON §

BEFORE ME, the undersigned notary, personally appeared Justin Bono, the affiant, a person who is known to me. After administering an oath, the affiant testified that:

1. “My name is Justin Bono, Manager of Astra Investments GP, LLC, a Texas limited liability company, the Managing General Partner of Denton Oliver Creek, LP, a Texas limited partnership, the Petitioner in the above-referenced matter. I am over the age of eighteen years, of sound mind, and am capable of making this affidavit. The facts stated in this affidavit are within my personal knowledge and are true and correct.

2. Petitioner owns approximately 570.976 acres of land (the “Property”), which is located within the boundaries of sewer CCN No. 21059 issued by Aqua Texas, Inc. Petitioner seeks a partial expedited release from sewer CCN. No. 21059 (the “Requested Area”). Exhibits “B” and “C” attached to this Petition are true and correct copies of a general location and detailed map of the Property. Petitioner is owner of this land as evidenced by the Special Warranty Deed, attached as Exhibit “D.” Exhibit “E” attached to this Petition is a true and correct copy of the ALTA survey for the Property. Digital mapping of the Property has been previously submitted in this docket.

3. The Requested Area is not receiving sewer service from Aqua Texas, Inc. or any other service provider. The Requested Area has not requested sewer service from Aqua Texas, Inc. or paid any fees or charges to initiate or maintain sewer service, and there are no billing records or other documents indicating an existing account for the Requested Area.

4. I request that the Public Utility Commission of Texas release the Requested Area from Sewer CCN No. 21059.”

FURTHER AFFIANT SAYETH NOT.



DENTON OLIVER CREEK, LP, a Texas
limited partnership

By: Astra Investments GP, LLC, a Texas
limited liability company, its Managing
General Partner

By: Justin Bono, Manager

SWORN TO AND SUBSCRIBED TO BEFORE ME by Justin Bono on 9 May, 2022.



Notary Public, State of Texas

EXHIBIT "B"

General Location Map

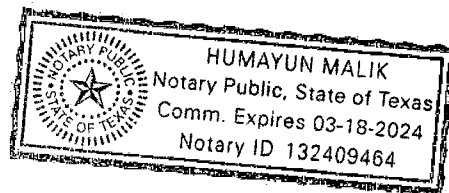
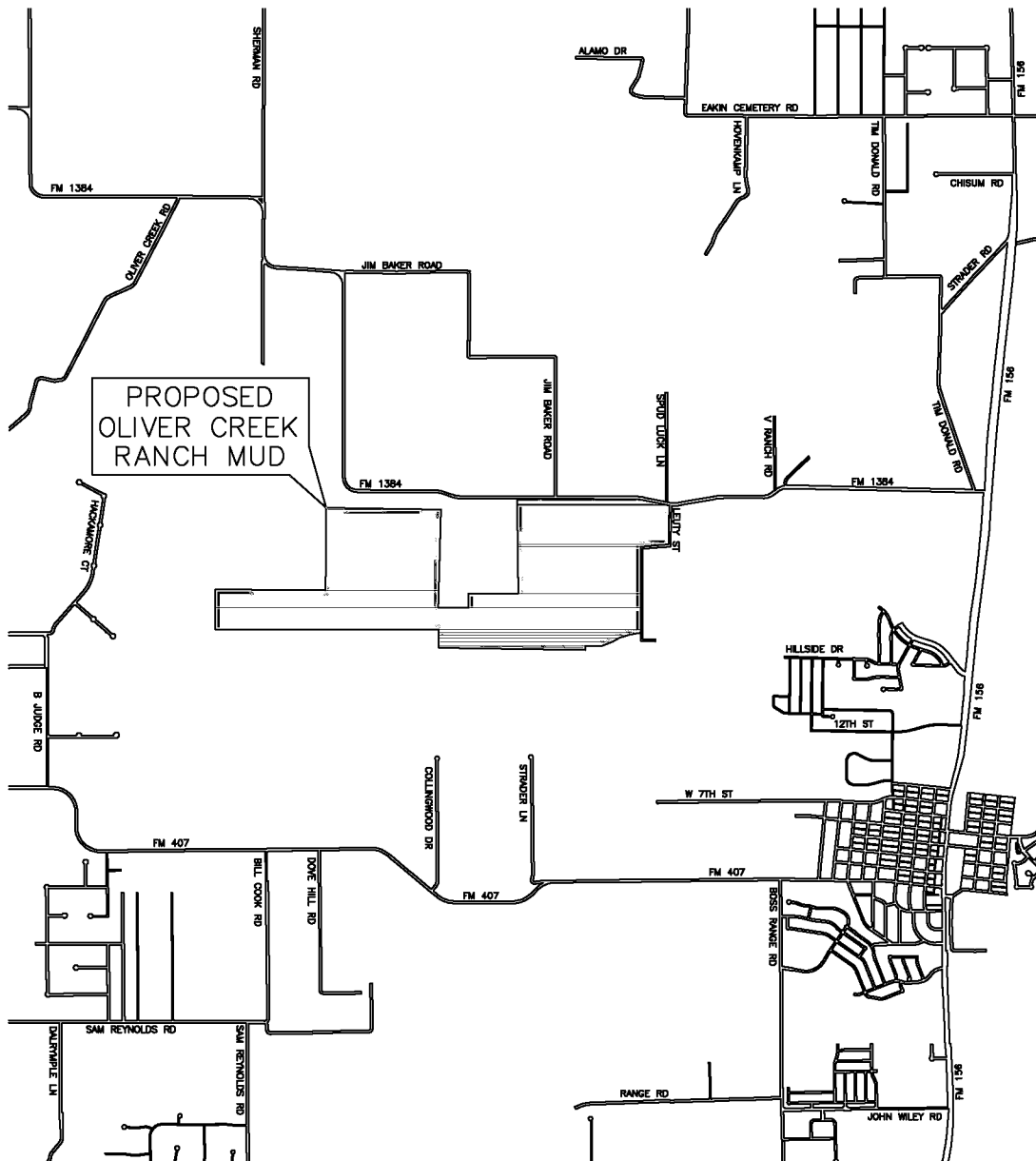

CIVIL ENGINEERS & SURVEYORS
FRISCO, TEXAS

BGE, Inc.

OLIVER CREEK RANCH MUNICIPAL UTILITY DISTRICT LOCATION MAP

Scale:

N.T.S.

Job No.:

8921-02

Date:

FEB., 2022

EXHIBIT “C”

Detailed Map

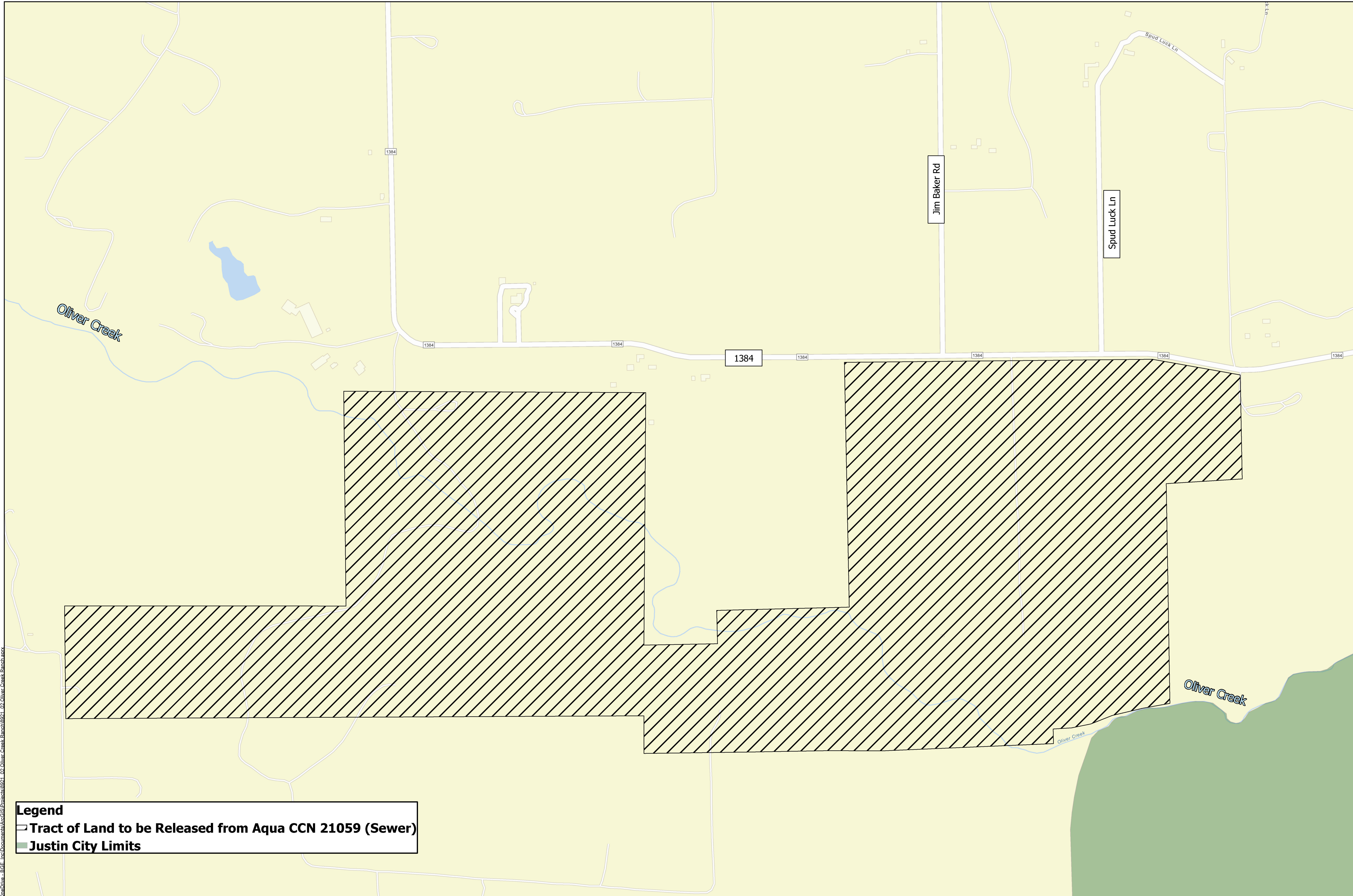

Tract of land for decertification is located in Denton County, northwest of Justin, TX, west of the FM 1384 and FM 156 intersection, south of FM 1384, and north of Oliver Creek.

Legend

-  Tract of Land to be Released from Aqua CCN 21059 (Sewer)
-  Justin City Limits

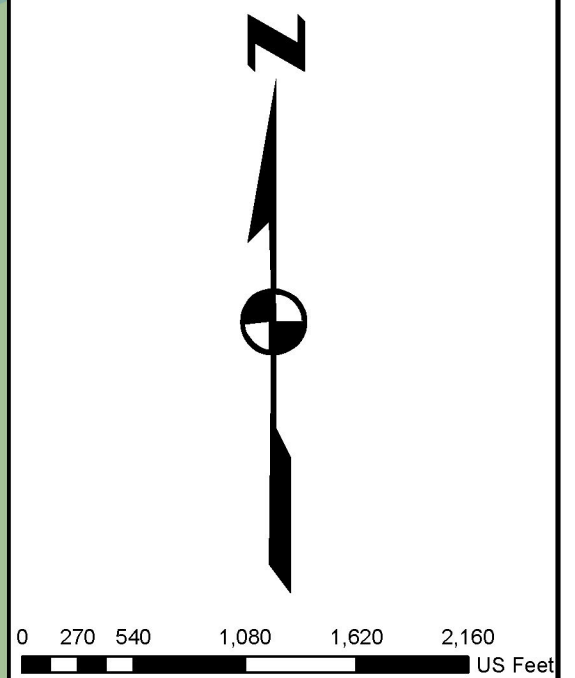

Disclaimer:
Every effort has been made to ensure the accuracy of the basemap data. BGE, Inc. assumes no liability or damages due to errors or omissions.

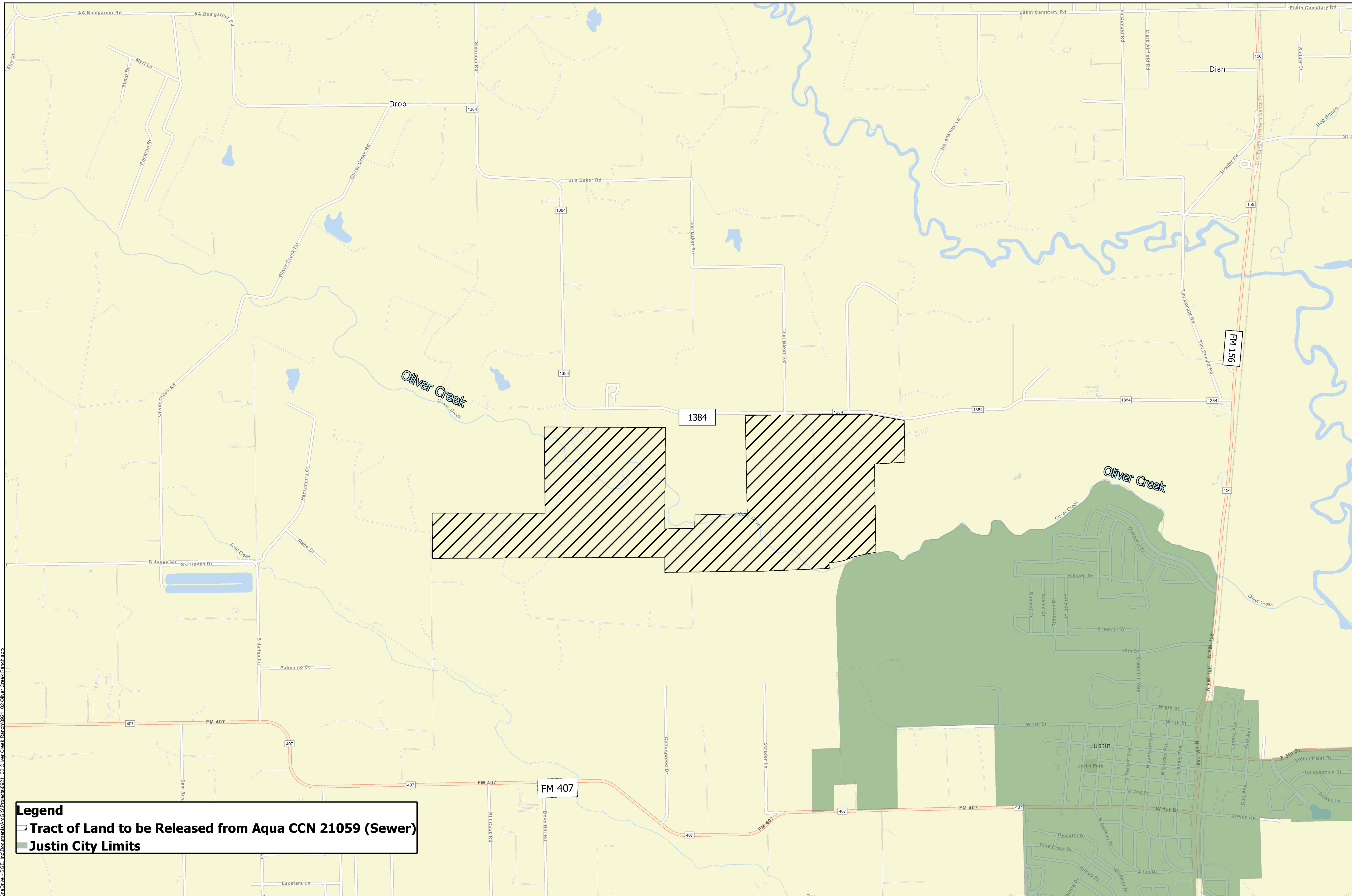

Legend
 [Hatched Box] Tract of Land to be Released from Aqua CCN 21059 (Sewer)
 [Green Box] Justin City Limits

Tract of land for decertification is located in Denton County, northwest of Justin, TX, west of the FM 1384 and FM 156 intersection, south of FM 1384, and north of Oliver Creek.



0 270 540 1,080 1,620 2,160 US Feet

Disclaimer:
 Every effort has been made to ensure the accuracy of the basemap data. BGE, Inc. assumes no liability or damages due to errors or omissions.

Tract of Land to be Released from Aqua CCN 21059 (Sewer)

EXHIBIT “D”

Special Warranty Deed

EXHIBIT "D"

Special Warranty Deed

Denton County
Juli Luke
County Clerk

Instrument Number: 229180

ERecordings-RP

DEED

Recorded On: December 17, 2021 04:10 PM

Number of Pages: 11

" Examined and Charged as Follows: "

Total Recording: \$66.00

***** THIS PAGE IS PART OF THE INSTRUMENT *****

Any provision herein which restricts the Sale, Rental or use of the described REAL PROPERTY because of color or race is invalid and unenforceable under federal law.

File Information:

Document Number: 229180
Receipt Number: 20211217000770
Recorded Date/Time: December 17, 2021 04:10 PM
User: Joy R
Station: Station 19

Record and Return To:

Corporation Service Company



STATE OF TEXAS
COUNTY OF DENTON

I hereby certify that this Instrument was FILED In the File Number sequence on the date/time printed hereon, and was duly RECORDED in the Official Records of Denton County, Texas.

Juli Luke
County Clerk
Denton County, TX

NOTICE OF CONFIDENTIALITY RIGHTS: IF YOU ARE A NATURAL PERSON, YOU MAY REMOVE OR STRIKE ANY OR ALL OF THE FOLLOWING INFORMATION FROM ANY INSTRUMENT THAT TRANSFERS AN INTEREST IN REAL PROPERTY BEFORE IT IS FILED FOR RECORD IN THE PUBLIC RECORDS: YOUR SOCIAL SECURITY NUMBER OR YOUR DRIVER'S LICENSE NUMBER.

SPECIAL WARRANTY DEED

STATE OF TEXAS §
 § KNOW ALL MEN BY THESE PRESENTS:
COUNTY OF DENTON §

THAT, GLENN AND LOUISE SHOOP FAMILY PARTNERSHIP, LTD, a Texas limited partnership ("**Grantor**"), for and in consideration of the sum of Ten and No/100 Dollars (\$10.00), and other good and valuable consideration, the receipt and sufficiency of which are hereby acknowledged, paid to Grantor by DENTON OLIVER CREEK, LP, a Texas limited partnership, having an address at 3625 Hall Street, Suite 700, Dallas, Texas 75219 ("**Grantee**") has GRANTED, BARGAINED, SOLD and CONVEYED, and by these presents does GRANT, BARGAIN, SELL and CONVEY unto Grantee, that certain land (the "**Land**") situated in Denton County, Texas, more particularly described on **Exhibit A** attached hereto and incorporated herein by reference for all purposes, together with (a) all improvements thereon, (b) all easements, rights and appurtenances pertaining thereto, (c) all rights, title, and interests of Grantor in and to adjacent streets, alleys, or rights-of-way, whether open or proposed, (d) any strips or gores between the above-described Land and any adjacent land, and (e) any land lying in or under the bed of any creek, stream or waterway, in, across, abutting or adjacent to the above-described Land.

Notwithstanding anything to the contrary contained or implied herein, Grantor hereby expressly (i) reserves all oil, gas and other minerals in, on or under the Land that may now or in the future be extracted or removed from the Land, and (ii) waives in favor of Grantee and its successors and assigns any and all rights to utilize the surface estate of the Property for any and all uses whatsoever including, but not limited to, drilling, extraction, production or other exploration or mining for oil, gas or other minerals or the storage or transportation thereof or any other use relating to such reserved oil, gas or other minerals except on existing pad sites. Nothing herein shall be construed as waiving, releasing or relinquishing any right, title or interest of Grantor in and to the Minerals. Additionally, the waiver of surface rights contained herein shall not be construed as a waiver of the right of Grantor to exploit, explore for, develop, mine, or produce the Minerals with wells drilled on the surface of lands other than the Land, including, but not limited to, directional or horizontal wells bottomed beneath or drilled through any part (other than the surface) of the Land or by pooling the oil, gas and mineral interests with lands adjoining the Land in accordance with the laws and regulations of the State of Texas. Operations for the exploration or recovery of the Minerals conducted on the surface and/or subsurface of other lands shall be permissible so long as all surface operations in connection therewith are located at points outside the surface of the Land, do not materially and adversely affect the surface of the Land or any improvements located thereon, and in no event shall such directional drilling or other subsurface activities intersect the boundaries of the Property at depths less than 600 feet below the surface of the Land.

This conveyance and the warranties of title contained herein are expressly made subject only to those certain encumbrances, easements and other matters more particularly described on **Exhibit B** attached hereto and incorporated herein by reference (the "**Permitted Exceptions**"), but only to the extent that such Permitted Exceptions are valid, subsisting and, in fact, affect the Property.

TO HAVE AND TO HOLD the Property (subject to the foregoing) unto Grantee and Grantee's successors and assigns forever, and Grantor does hereby bind Grantor and Grantor's successors and assigns to WARRANT and FOREVER DEFEND, all and singular, the Property unto Grantee and Grantee's successors and assigns, against every person whomsoever lawfully claiming or to claim the same or any part thereof, by, through or under Grantor, but not otherwise.

Ad valorem taxes relating to the Land have been prorated between Grantor and Grantee as of the date hereof, subject to reconciliation and adjustment after the date hereof pursuant to the terms and provisions of Real Estate Purchase and Sale Agreement by and between Seller and Purchaser relating to the Property.

[THE BALANCE OF THIS PAGE IS INTENTIONALLY BLANK

EXECUTED to be effective as of the 10 day of December, 2021.

GRANTOR:

GLENN AND LOUISE SHOOP FAMILY
PARTNERSHIP, LTD
a Texas limited partnership

By: Nancy Jeffery
Name: Nancy Jeffery
Title: Authorized Representative
Date: December 10, 2021

THE STATE OF ARKANSAS §
 §
COUNTY OF PULASKI §

BEFORE ME, the undersigned authority, on this day personally appeared Nancy Jeffery, Authorized Representative of GLENN AND LOUISE SHOOP FAMILY PARTNERSHIP, LTD, a Texas limited partnership, known to me to be the person whose name is subscribed to the foregoing instrument, and acknowledged to me that she executed the same for the purpose and consideration and in the capacity therein expressed.

GIVEN UNDER MY HAND AND SEAL OF OFFICE this 10 day of December, 2021.

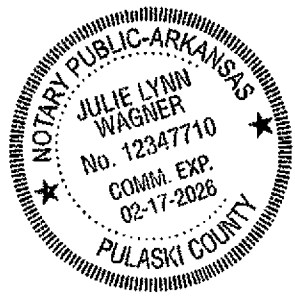

Julie Lynn Wagner
Notary Public in and for the State of Arkansas

AFTER RECORDING RETURN TO:

Bellinger & Suberg, L.L.P.
12221 Merit Drive, Suite 1750
Dallas, Texas 75251
Attention: Glen A. Bellinger

SEND TAX NOTICES TO:

Denton Oliver Greek, LP
3625 Hall Street, Suite 700
Dallas, Texas 75219
Attention: Justin Bono

EXHIBIT A
TO DEED

LEGAL DESCRIPTION OF THE LAND

BEING, all of that 570.976 acres (24,871,702 square foot) tract of land situated in the William C. Harrison Survey, Abstract Number 523; the M.E.P.&P. R.R. Co. Survey, Abstract Number 908; the William Reed Survey, Abstract Number 1071; the Joseph Sutton Survey, Abstract Number 1151; and the S.F. Reynolds Survey, Abstract Number 1627 in Denton County, Texas; being all of those tracts of land described as Tract III, Tract IV, Tract V, Tract VI, and Tract VII in General Warranty Deed to Glenn and Louise Shoop Family Partnership, Ltd. as recorded in Instrument Number 2005-17852 of the Official Records of Denton County, Texas; said 570.976 acre tract of land being more particularly described by metes and bounds as follows:

BEGINNING, at a 1/2-inch iron with "OWEN 5560" cap found for corner in the east line of said Tract VII; said point being in the south right-of-way line of F.M. 1384 (80-foot wide right-of-way); said point being the northwest corner of that tract of land described as Tract One in Warranty Deed to Henry A. Pennington, Janice K. Coomer and Gary Michael Pennington as recorded in Volume 1474, Page 811 of the Deed Records of Denton County, Texas;

THENCE, with the east line of said Tract VII, the following three (3) courses and distances:

South 00 degrees 21 minutes 00 seconds East, a distance of 973.41 feet to a 1/2-inch iron with "OWEN 5560" cap found for corner; said point being the southwest corner of said Pennington tract; said point being in the north line of that tract of land described in Special Warranty Deed to Susan H. Michaud, et al as recorded in Volume 4345 Page 516 and Volume 4345, Page 522 of said Deed Records;

South 87 degrees 10 minutes 00 seconds West, a distance of 712.46 feet to a 1/2-inch iron with "OWEN 5560" cap found at the northwest corner of said Michaud tract;

South 00 degrees 13 minutes 01 seconds East, with the west line of said Michaud tract, a distance of 2,055.21 feet to a point at the southeast corner of said Tract VII; said point being in the north line of that called 411.268 acre tract of land described in Special Warranty Deed with Reservation of Reserved Substances to Justin Timberbrook, LLC as recorded in Instrument Number 2016-55837 of said Official Records;

THENCE, with the south line of said Tract VII and the north line of said 411.268 acre tract, the following eleven (11) courses and distances:

South 80 degrees 38 minutes 21 seconds West, along an old barbed wire fence, at a distance of 24.5 feet passing a wood fence corner post found, continuing in all a total distance of 197.40 feet to a point for corner;

South 79 degrees 48 minutes 06 seconds West, along said fence, a distance of 122.22 feet to a point for corner;

South 77 degrees 15 minutes 37 seconds West, along said fence, a distance of 173.28 feet to a point for corner;

South 75 degrees 33 minutes 19 seconds West, along said fence, a distance of 59.27 feet to a point for corner;

South 70 degrees 53 minutes 37 seconds West, along said fence, a distance of 103.09 feet to a point for corner;

South 67 degrees 32 minutes 32 seconds West along said fence, a distance of 112.17 feet to a point for corner;

South 79 degrees 28 minutes 02 seconds West, along said fence, a distance of 146.75 feet to a wood fence corner post found for corner;

South 78 degrees 00 minutes 08 seconds West, along said fence, a distance of 72.98 feet to a wood fence corner post found for corner;

South 89 degrees 40 minutes 49 seconds West, departing said fence, a distance of 136.91 feet to a point for corner;

South 00 degrees 19 minutes 11 seconds East, a distance of 136.70 feet to a point for corner;

South 88 degrees 49 minutes 57 seconds West, a distance of 506.57 feet to a point at the northwest corner of said 411.268 acre tract; said point being the northeast corner of that called 241.210 acre tract of land described in Special Warranty Deed to Justin Timberbrook, LLC as recorded in Instrument Number 2017-5803 of said Official Records;

THENCE, with the south line of said Tract VII, Tract V and the north line of said 241.210 acre tract, the following five (5) courses and distances:

South 86 degrees 30 minutes 23 seconds West, a distance of 130.74 feet to a point for corner;

South 88 degrees 05 minutes 08 seconds West, a distance of 888.24 feet to a point for corner;

North 88 degrees 19 minutes 54 seconds West, a distance of 342.20 feet to a 3/8 inch iron rod found for corner;

South 89 degrees 52 minutes 01 seconds West, a distance of 690.08 feet to a 3/8 inch iron rod found for corner;

South 89 degrees 08 minutes 49 seconds West, a distance of 205.87 feet to a 5/8 inch iron rod found at the northwest corner of said 241.210 acre tract; said point being the northeast

corner of that called 18.000 acre tract of land described in General Warranty Deed to Keo Chanthalath, et al as recorded in Instrument Numbers 2012-136327 and 2013-2597 of said Official Records;

THENCE, North 89 degrees 44 minutes 49 seconds West, a distance of 418.46 feet to a 1/2 inch iron rod found at the northwest corner of said 18.000 acre tract; said point being the northeast corner of that tract of land described as Tract 1 in Special Warranty Deed to Justin Timberbrook, LLC as recorded in Instrument Number 2017-4977 of said Official Records;

THENCE, with the south line of said Tract V, Tract III, Tract VI and the north line of said Tract 1, the following three (3) courses and distances:

South 89 degrees 51 minutes 07 seconds West, a distance of 651.30 feet to a 1/2 inch iron rod found for corner;

North 00 degrees 38 minutes 39 seconds East, a distance of 352.67 feet to a 1/2 inch iron rod found for corner;

North 89 degrees 32 minutes 14 seconds West, at a distance of 987.44 feet passing a 1/2 inch iron rod with "COLEMAN RPLS 4001" cap found, at a distance of 2,777.28 passing a 1/2 inch iron rod with illegible cap found for corner, at a distance of 4,527.42 feet passing a 1/2 inch iron rod with "COLEMAN RPLS 4001" cap found, continuing in all a total distance of 5,409.40 feet to 1/2 inch iron rod with "COLEMAN RPLS 4001" cap found at the southwest corner of said Tract VI and the northwest corner of said Tract 1; said point being in the east line of that tract of land described in Special Warranty Deed to JNJDF, Ltd. as recorded in Instrument Number 2008-85490 of said Official Records;

THENCE, North 00 degrees 06 minutes 11 seconds East, with the west line of said Tract VI and with the east line of said JNJDF tract, a distance of 1,055.11 feet to a wood fence corner post found at the northwest corner of said Tract VI; said point being in the south line of that tract of land described as Tract 10 in Special Warranty Deed to Trustee of the Mark Wallace Exempt Family Trust, et al as recorded in Instrument Number 2019-157304 of said Official Records;

THENCE, South 89 degrees 13 minutes 25 seconds East, with the north line of said Tract VI and with the south line of said Tract 10 tract, a distance of 2,633.65 feet to a wood fence corner post found at the northeast corner of said Tract VI; said point being the southeast corner of said Tract 10; said post being in the west line of said Tract IV;

THENCE, North 00 degrees 07 minutes 19 seconds East, with the west line of said Tract IV and with the east line of said Tract 10, a distance of 2,009.39 feet to a wood fence corner post found at the northwest corner of said Tract IV; said point being in the south line of that tract of land described as Tract 11 in said Special Warranty Deed to Trustee of the Mark Wallace Exempt Family Trust;

THENCE, South 88 degrees 59 minutes 56 seconds East, with the north line of said Tract IV, a distance of 2,826.49 feet to a wood fence corner post found at the northeast corner of said Tract

III; said point being in the west line of that called 43.439 acre tract of land described in Special Warranty Deed to Billie Louise Brasher as recorded in Instrument Number 2021-12751 of said Official Records;

THENCE, South 01 degrees 10 minutes 06 seconds West, with the east line of said Tract III and with the west line of said 43.439 acre tract, a distance of 2,362.40 feet to a point at the northwest corner of said Tract V; from said point a 3/8-inch iron rod found bears South 49 degrees 42 minutes West, a distance of 1.4 feet;

THENCE, with the north line of said Tract V and the south line of said 43.439 acre tract, the following three (3) courses and distances:

North 89 degrees 41 minutes 24 seconds East, a distance of 689.40 feet to a point for corner;

North 00 degrees 40 minutes 55 seconds West, a distance of 311.78 feet to a point for corner;

North 89 degrees 19 minutes 09 seconds East, a distance of 1,240.70 feet to a wood fence corner post found at the northeast corner of said Tract V and the southeast corner of said 43.439 acre tract; said point being in the west line of said Tract VII;

THENCE, North 00 degrees 23 minutes 18 seconds West, with the west line of said Tract VII, a distance of 2,290.64 feet to a wood fence corner post found at the northwest corner of said Tract VII; said point being the northeast corner of that tract of land described as Tract Two in Special Warranty Deed to Peggy DeAnne Hatfield as recorded in Instrument Number 2021-12752 of said Official Records; said point being in the south line of said F.M. 1384;

THENCE, with the north line of said Tract VII and the south line of said F.M. 1384, the following five (5) calls:

South 89° 43' 00" East, a distance of 919.41 feet to a point for corner;

South 89° 59' 19" East, a distance of 1,874.35 feet to a point for corner at the beginning of a tangent curve to the right;

In a southeasterly direction, with said curve to the right, an arc length of 177.93 feet, having a radius of 911.89 feet, a central angle of 11° 10' 47", and a chord which bears South 84° 23' 56" East, 177.65 feet to a point for corner;

South 78° 48' 32" East, a distance of 700.66 feet to a 1/2-inch iron with "OWEN 5560" cap found for corner at the beginning of a tangent curve to the left;

In a southeasterly direction, with said curve to the left, an arc length of 44.41 feet, having a radius of 749.85 feet, a central angle of 03° 23' 36", and a chord which bears South 80° 30' 20" East, 44.40 feet to the POINT OF BEGINNING and containing an area of 570.976 acres or 24,871,702 square feet of land, more or less.

EXHIBIT B
TO DEED

PERMITTED EXCEPTIONS

1. All leases, grants, exceptions or reservations of coal, lignite, oil, gas and other minerals, together with all rights, privileges, and immunities relating thereto, appearing in the Public Records of Denton County, Texas.
2. Easement executed by Glen P. Shoop to Southwestern Gas Pipeline, Inc., dated May 16, 1994, recorded in/under Clerk's File Number 94-R0045628 of the Real Property Records of Denton County, Texas; and as noted on survey dated June 21, 2021, prepared by Rene Silvas, R.P.L.S.# 5921.
3. Easement executed by Glen P. Shoop to Mitchell Energy and Development, Corp., dated March 6, 1989, filed September 16, 1996, recorded in/under Clerk's File Number 96-R0064802 of the Real Property Records of Denton County, Texas; and as shown on survey dated June 21, 2021, prepared by Rene Silvas, R.P.L.S.# 5921.
4. Easement executed by Glen P. Shoop to Southwestern Gas Pipeline, Inc., filed August 18, 1998, recorded in/under Clerk's File Number 199800074674 of the Real Property Records of Denton County, Texas; and as shown on survey dated June 21, 2021, prepared by Rene Silvas, R.P.L.S.# 5921.
5. Easement executed by Glen P. Shoop to Southwestern Gas Pipeline, Inc., filed March 30, 1999, recorded in/under Clerk's File Number 199900029958 (Volume 4307, Page 1225) of the Real Property Records of Denton County, Texas; and as noted on survey dated June 21, 2021, prepared by Rene Silvas, R.P.L.S.# 5921
6. Easement executed by Glen P. Shoop to Southwestern Gas Pipeline, Inc., filed January 25, 2000, recorded in/under Clerk's File Number 200000007545 (Volume 4512, Page 1465) of the Real Property Records of Denton County, Texas; and as shown on survey dated June 21, 2021, prepared by Rene Silvas, R.P.L.S.# 5921.
7. Easement executed by Glen P. Shoop and Louise V. Shoop to Southwestern Gas Pipeline, Inc., May 15, 2001, recorded in/under Clerk's File Number 200100045865 (Volume 4837, Page 1856) of the Real Property Records of Denton County, Texas; and as noted on survey dated June 21, 2021, prepared by Rene Silvas, R.P.L.S.# 5921.
8. Easement executed by Glen P. Shoop and Louise V. Shoop to Cantera Resources, Inc., filed July 13, 2001, recorded in/under Clerk's File Number 20010070149 (Volume 4878, Page 100) of the Real Property Records of Denton County, Texas; and as noted on survey dated June 21, 2021, prepared by Rene Silvas, R.P.L.S.# 5921.
9. Easement and Right-of-Way executed by Glenn and Louise Shoop Family Partnership, LTD., to Crosstex North Texas Pipeline, LP, dated November 15, 2005, filed December 2, 2005, recorded in/under Clerk's File Number 200500149197 of the Real Property Records

of Denton County, Texas; and as shown on survey dated June 21, 2021, prepared by Rene Silvas, R.P.L.S.# 5921.

10. Right-of-Way agreement executed by Glenn P. Shoop to Southwestern Gas Pipeline, Inc, dated July 24, 2006, filed August 28, 2006, recorded in/under Clerk's File Number 2006-106037 of the Real Property Records of Denton County, Texas; and as shown on survey dated June 21, 2021, prepared by Rene Silvas, R.P.L.S.# 5921.
11. Right-of-Way agreement executed by Glenn P. Shoop to Southwestern Gas Pipeline, Inc, dated November 17, 2006, filed January 3, 2007, recorded in/under Clerk's File Number 200700001065 of the Real Property Records of Denton County, Texas; and as noted on survey dated June 21,2021, prepared by Rene Silvas, R.P.L.S.# 5921.
12. Easement and Right-of-Way executed by Glenn and Louise Shoop Family Partnership, LTD., to Energy Transfer Fuel, LP, dated February 21, 2007, filed February 26, 2007, recorded in/under Clerk's File Number 200700022528 of the Real Property Records of Denton County, Texas; and as shown on survey dated June 21, 2021, prepared by Rene Silvas, R.P.L.S.# 5921.
13. Right-of-Way agreement executed by Shoop Partnership GP, LLC to Southwestern Gas Pipeline, Inc, filed November 3, 2008, recorded in/under Clerk's File Number 200800118586 of the Real Property Records of Denton County, Texas; and as noted on survey dated June 21, 2021, prepared by Rene Silvas, R.P.L.S.# 5921.
14. Right-of-Way agreement executed by Glenn & Louise Shoop Family Partnership, Ltd. to Southwestern Gas Pipeline, Inc, filed December 4, 2008, recorded in/under Clerk's File Number 200800129064 of the Real Property Records of Denton County, Texas; and as shown on survey dated June 21, 2021, prepared by Rene Silvas, R.P.L.S.# 5921.
15. Right of Way Agreement by and between the Joy Nell Frazier, grantor, and Southwestern Gas Pipeline, Inc., grantee as set for and defined by the instrument recorded under Denton County Clerk's File No(s) 199400021053 of the Official Public Records of Denton County, Texas; and as noted on survey dated June 21, 2021, prepared by Rene Silvas, R.P.L.S.# 5921.
16. Easement granted to Enterprise Texas Pipeline LLC, a Texas limited liability company, as set for and defined by the instrument recorded under Denton County Clerk's File No(s) 200900029758 of the Official Public Records of Denton County, Texas; and as shown on survey dated June 21, 2021, prepared by Rene Silvas, R.P.L.S.# 5921.
17. Easements awarded to Enbridge Gathering (North Texas) L.P., as Plaintiff and the easements granted to the Glenn and Louise Shoop Family Partnership, Ltd., in the Judgement filed under Cause No. PR-2010-00178 of the Probate Records of Denton County, Texas, and as set forth and defined by the instrument recorded under Denton County Clerk's File No(s) 201200034816 of the Official Public Records of Denton County, Texas; and as shown on survey dated June 21, 2021, prepared by Rene Silvas, R.P.L.S.# 5921.

18. Right of Way Agreement by and between the Glenn and Louise Shoop Family Partnership, Ltd., grantor, and Southwestern Gas Pipeline, Inc., grantee, as set forth and defined by the instrument recorded under Denton County Clerk's File No(s) 201100101556 of the Official Public Records of Denton County, Texas; and as shown on survey dated June 21, 2021, prepared by Rene Silvas, R.P.L.S.# 5921.
19. Subject to the location of fences on the property as set out and shown on the survey dated June 21, 2021, made by Rene Silvas, Registered Professional Land Surveyor No. 5921.
20. Subject to the location of gas lines and gas appurtenances on subject property as set out and shown on the survey dated June 21, 2021, made by Rene Silvas, Registered Professional Land Surveyor No. 5921.

EXHIBIT “E”

ALTA survey

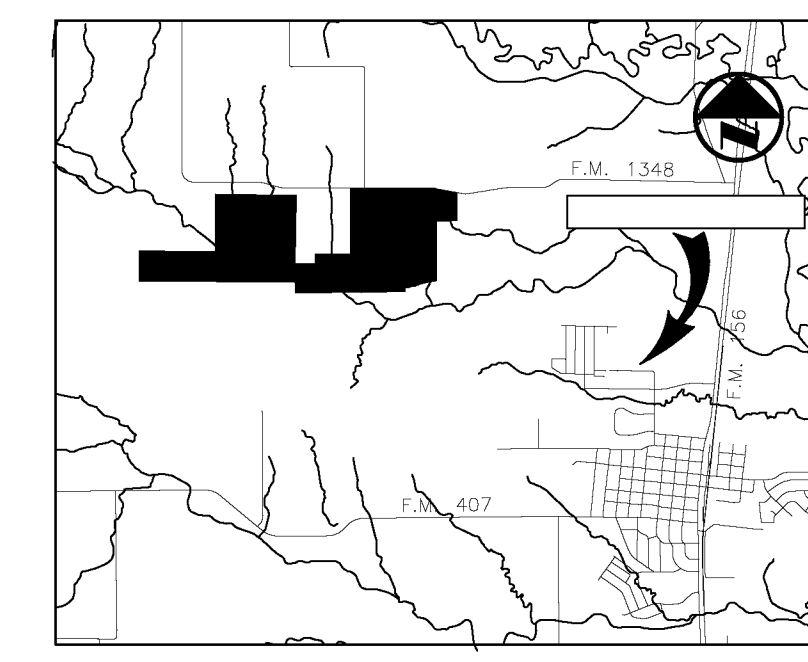

VICINITY MAP (NOT TO SCALE)

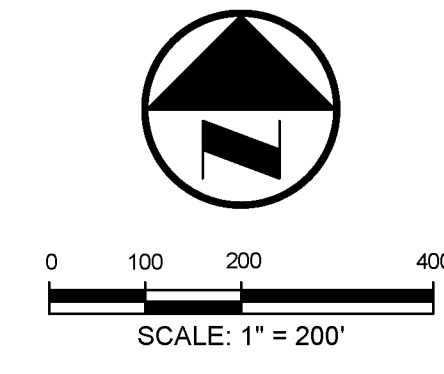

LEGEND

- 5/8-INCH IRON ROD W/ "BGE" CAP SET
- MONUMENT OF RECORD DIGNITY
- OFFICIAL PUBLIC RECORDS, DENTON COUNTY, TEXAS
- O.R.D.C.T.
- D.R.D.C.T.
- DEED RECORDS, DENTON COUNTY, TEXAS
- INST. INSTRUMENT
- VOL. VOLUME
- NO. NUMBER
- PG. PAGE
- P.O.B. POINT OF BEGINNING
- PROPERTY LINE
- EASEMENT LINE
- ABSTRACT LINE
- FLOODPLAIN LINE

GENERAL NOTES:

1. Bearing system for this survey is based on the Texas State Plane Coordinate System - NAD 83, North Central Zone 4202, based on observations made on June 3, 2021 with an applied combined scale factor of 1.0001063.
2. The floodplain boundaries shown hereon are approximate and are not depicted as a result of an on-the-ground survey. The subject tract lies with Zone X and Zone A as delineated on Flood Insurance Rate Map for Denton County, Texas and Incorporated Areas, Map Number 48121C04803 with Map Revised April 18, 2011.
Zone X - Areas determined to be outside the 0.2% annual chance floodplain
Zone A - No base flood elevations determined
3. This survey was prepared with the aid of a title commitment. A thorough search of county public deed records was performed for encumbrances, rights-of-way, limitations, restrictions, or encumbrances. The surveyor did not abstract the property and any valid claim that may affect, restrict, or otherwise encumber subject tract not found or shown hereon shall not create liability on the part of the Surveyor. This survey was made relying upon that certain commitment for title insurance issued by Fidelity National Title Insurance Company under G.F. number 780002298, effective date of November 28, 2021 and issued date of December 9, 2021.
4. The square footage value shown hereon is a mathematical value calculated from the boundary data shown hereon. This value in no way represents the precision of closure of this survey or the accuracy of corner monuments found or placed.
5. Fences depicted hereon are based on locations measured in the field; the dimensions less shown are at those particular locations labeled only; the fence lines may meander between said measured locations.
6. Oliver Creek shown on this survey based on publicly available aerial photography in accordance with Table A, Item 15.
7. There appear to be apparent gas line and gas appurtenance encroachments in multiple locations across the subject property. However, there are also multiple easements that are blanket in nature that may cover these.

SURVEYOR'S CERTIFICATE

To: Astra Investments II, LLC,
Denton Oliver Creek, LP,
Glenn and Louise Shoop Family Partnership, LTD,
National Title Group, LLC, and
Fidelity National Title Insurance Company.

This is to certify that this map or plat and the survey on which it is based were made in accordance with the 2021 Minimum Standard Detail Requirements for ALTA/NSPS Land Title Surveys, jointly established and adopted by ALTA and NSPS, and includes Items 2, 3, 4, 5, 13 & 15 of Table A thereof. The fieldwork was completed on June 21, 2021.

Date of Plat or Map: June 21, 2021

Rene Silvas
Rene Silvas, RPLS No. 8921

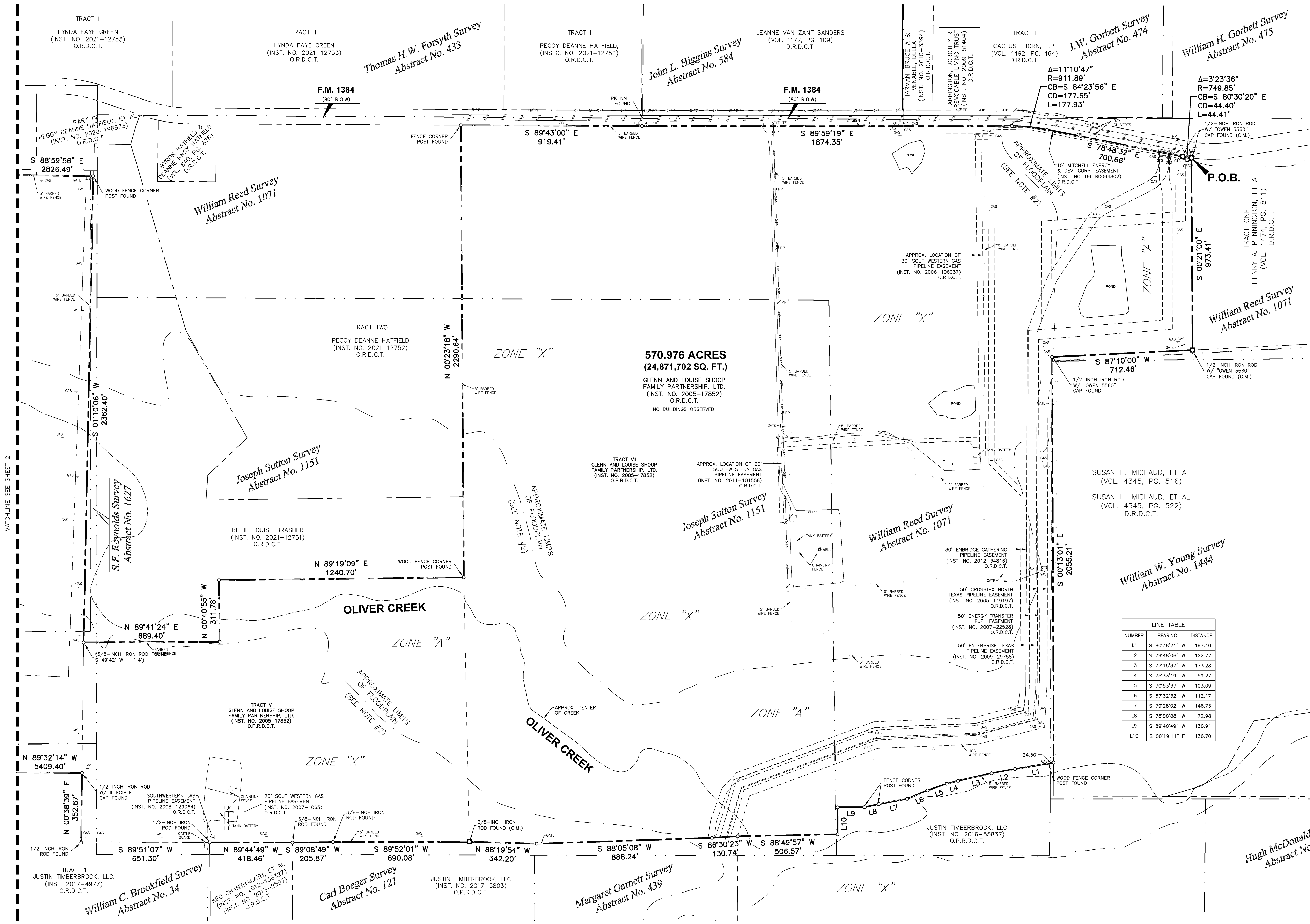

NUMBER	BEARING	DISTANCE
L1	S 80°38'21" W	197.40'
L2	S 79°48'06" W	122.22'
L3	S 77°15'37" W	173.28'
L4	S 75°33'19" W	59.27'
L5	S 70°53'37" W	103.09'
L6	S 67°32'32" W	112.17'
L7	S 79°28'02" W	146.75'
L8	S 78°00'08" W	72.98'
L9	S 89°40'49" W	136.91'
L10	S 00°19'11" E	136.70'

ALTA/NSPS LAND TITLE SURVEY
570.976 ACRES

BEING SITUATED IN THE
WILLIAM C. HARRISON SURVEY, ABSTRACT NO. 523,
M.E.P. & P. R.R. CO. SURVEY, ABSTRACT NO. 908,
WILLIAM REED SURVEY, ABSTRACT NO. 1071,
JOSEPH SUTTON SURVEY, ABSTRACT NO. 1151,
S.F. REYNOLDS SURVEY, ABSTRACT NO. 1627,
DENTON COUNTY, TEXAS

JUNE 21, 2021
SHEET 1 OF 2

CLIENT

ASTRA DEVELOPMENT
3625 Hall Street, Suite 720
Dallas, Texas 75219

SURVEYOR

BGE, Inc.
777 Main Street, Suite 1900, Fort Worth, TX 76102
Tel: 817-857-6130 • www.bgeinc.com
TBPLS Registration No. 10194416

Contact: Rene Silvas, R.P.L.S.
Telephone: (817) 752-4183 • Email: rsilvas@bgeinc.com

G:\TXM\Projects\Astra_Development\8921-05-Oliver_Creek_Ranch_ALTA_Survey\8921-05-ALTA.dwg 2021-12-10 11:38:18 AM

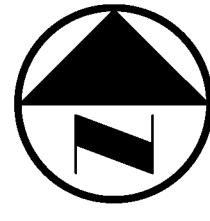

LEGEND

- C.I.R.S. 5/8-INCH IRON ROD W/ "BGE" CAP SET (C.M.) CONTROLLING MONUMENT
- O.R.D.C.T. OFFICIAL PUBLIC RECORDS, DENTON COUNTY, TEXAS
- D.R.D.C.T. DEED RECORDS, DENTON COUNTY, TEXAS
- INST. INSTRUMENT
- VOL. VOLUME
- NO. NUMBER
- PG. PAGE
- P.O.B. POINT OF BEGINNING
- PROPERTY LINE
- - - EASEMENT LINE
- ABSTRACT LINE
- - - FLOODPLAIN LINE

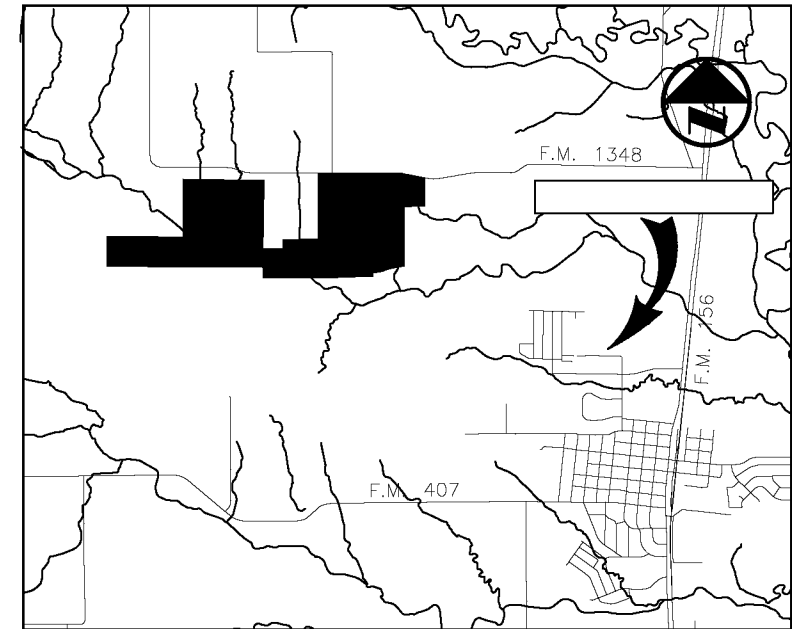

VICINITY MAP
(NOT TO SCALE)

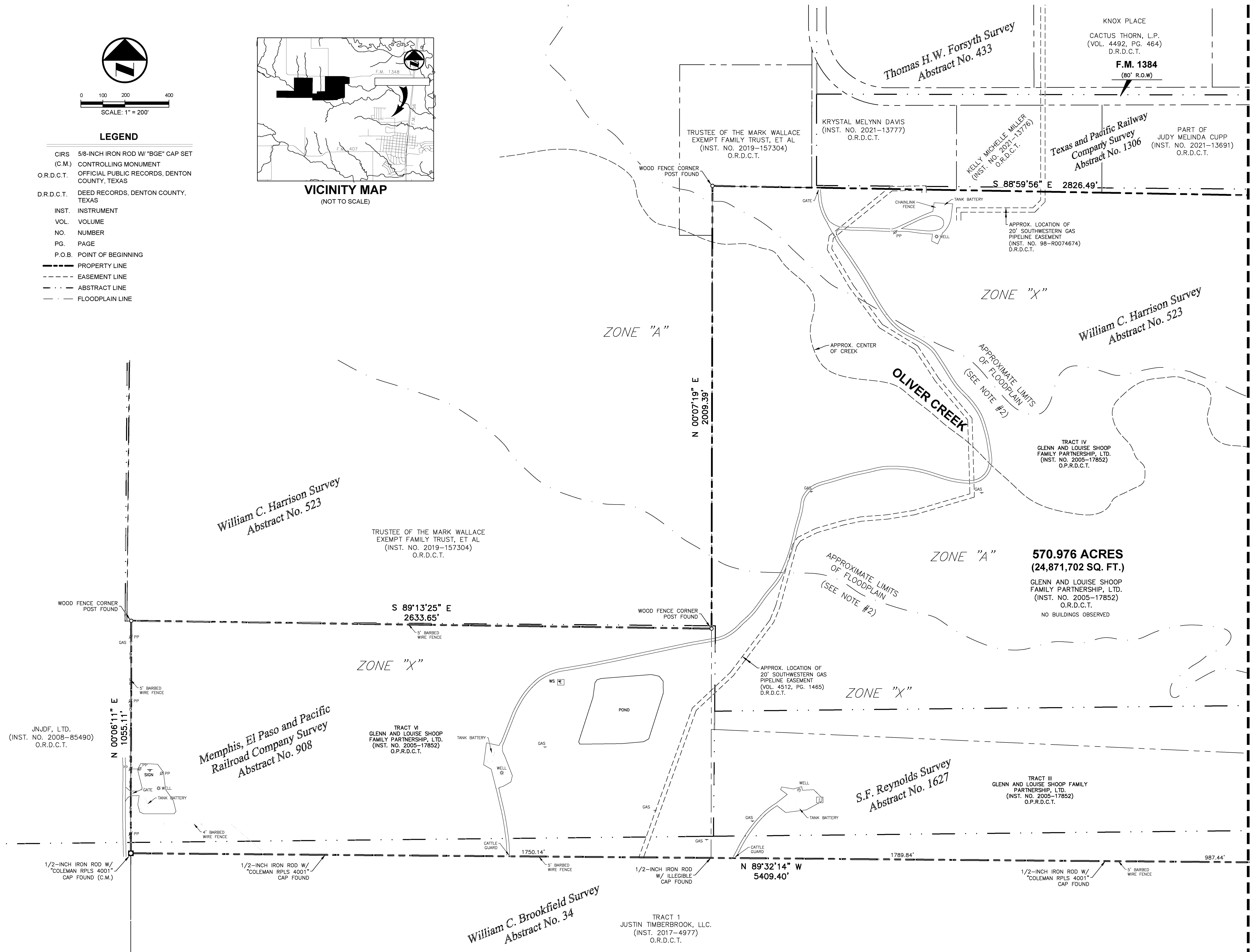

LEGAL DESCRIPTION:

BEING, all of that 570.976 acres (24,871,702 square foot) tract of land situated in the William C. Harrison Survey, Abstract Number 523, the M.E.P.&P. R.R. Co. Survey, Abstract Number 908, the William Reed Survey, Abstract Number 1071, the Joseph Sutton Survey, Abstract Number 1151, and the S.F. Reynolds Survey, Abstract Number 1627 in Denton County, Texas, being all of those tracts of land described as Tract VII, Tract VI, and Tract V in General Warranty Deed to Glenn and Louise Shoop Family Partnership, Ltd. as recorded in Instrument Number 2005-17852 of the Official Records of Denton County, Texas, said 570.976 acre tract of land being more particularly described by metes and bounds as follows:

BEGINNING, at a 1/2-inch iron with "OVEN 5560" cap found for corner in the east line of said Tract VII, said point being in the south right-of-way line of F.M. 1384 (80-foot wide right-of-way); said point being the northwest corner of that tract of land described as Tract One in Warranty Deed to Henry A. Pennington, Janice K. Coomer and Gary Michael Pennington as recorded in Volume 1474, Page 811 of the Deed Records of Denton County, Texas;

THENCE, with the east line of said Tract VII, the following three (3) courses and distances:

- South 00 degrees 21 minutes 00 seconds East, a distance of 973.41 feet to a 1/2-inch iron with "OVEN 5560" cap found for corner; said point being the southwest corner of said Pennington tract; said point being in the north line of that tract of land described in Special Warranty Deed to Susan H. Michael, et al as recorded in Volume 4345 Page 516 and Volume 4345, Page 522 of said Deed Records;
- South 87 degrees 10 minutes 00 seconds East, a distance of 712.46 feet to a 1/2-inch iron with "OVEN 5560" cap found at the northwest corner of said Michael tract;
- South 00 degrees 13 minutes 01 seconds East, with the west line of said Michael tract, a distance of 2,055.21 feet to a point at the southeast corner of said Tract VII; said point being in the north line of that called 411.268 acre tract of land described in Special Warranty Deed with Reservation of Reserved Substances to Justin Timberbrook, LLC as recorded in Instrument Number 2019-59857 of said Official Records;

THENCE, with the south line of said Tract VII and the north line of said 411.268 acre tract, the following eleven (11) courses and distances:

- South 89 degrees 38 minutes 21 seconds West, along an old barbed wire fence, at a distance of 24.5 feet passing a wood fence corner post found, continuing in all a total distance of 197.40 feet to a point for corner;
- South 79 degrees 48 minutes 06 seconds West, along said fence, a distance of 122.22 feet to a point for corner;
- South 77 degrees 15 minutes 37 seconds West, along said fence, a distance of 173.28 feet to a point for corner;
- South 75 degrees 33 minutes 19 seconds West, along said fence, a distance of 59.27 feet to a point for corner;
- South 70 degrees 53 minutes 37 seconds West, along said fence, a distance of 103.09 feet to a point for corner;
- South 67 degrees 32 minutes 32 seconds West along said fence, a distance of 112.17 feet to a point for corner;
- South 79 degrees 28 minutes 02 seconds West, along said fence, a distance of 146.75 feet to a wood fence corner post found for corner;
- South 78 degrees 00 minutes 08 seconds West, along said fence, a distance of 72.98 feet to a wood fence corner post found for corner;
- South 89 degrees 40 minutes 49 seconds West, departing said fence, a distance of 136.91 feet to a point for corner;
- South 00 degrees 19 minutes 11 seconds East, a distance of 136.70 feet to a point for corner;
- South 88 degrees 49 minutes 57 seconds West, a distance of 506.57 feet to a point at the northwest corner of said 411.268 acre tract; said point being the northeast corner of that called 241.210 acre tract of land described in Special Warranty Deed to Justin Timberbrook, LLC as recorded in Instrument Number 2017-5803 of said Official Records;

THENCE, with the south line of said Tract VII, Tract V and the north line of said 241.210 acre tract, the following five (5) courses and distances:

- South 86 degrees 30 minutes 23 seconds West, a distance of 130.74 feet to a point for corner;
- South 88 degrees 05 minutes 08 seconds West, a distance of 886.24 feet to a point for corner;
- North 88 degrees 19 minutes 54 seconds West, a distance of 342.20 feet to a 3/8 inch iron rod found for corner;
- South 89 degrees 52 minutes 01 seconds West, a distance of 690.06 feet to a 3/8 inch iron rod found for corner;
- South 89 degrees 08 minutes 49 seconds West, a distance of 206.87 feet to a 5/8 inch iron rod found at the northwest corner of said 241.210 acre tract; said point being the northeast corner of that called 18,000 acre tract of land described in General Warranty Deed to Ken Chantlath, et al as recorded in Instrument Numbers 2012-136327 and 2013-2597 of said Official Records;

THENCE, North 89 degrees 44 minutes 49 seconds West, a distance of 418.46 feet to a 1/2 inch iron rod found at the northwest corner of said 18,000 acre tract; said point being the northeast corner of that tract of land described as Tract 1 in Special Warranty Deed to Justin Timberbrook, LLC as recorded in Instrument Number 2017-4977 of said Official Records;

THENCE, with the south line of said Tract V, Tract VI and the north line of said Tract 1, the following three (3) courses and distances:

- South 89 degrees 51 minutes 07 seconds West, a distance of 651.30 feet to a 1/2 inch iron rod found for corner;
- North 00 degrees 38 minutes 39 seconds East, a distance of 352.67 feet to a 1/2 inch iron rod found for corner;
- North 89 degrees 32 minutes 14 seconds West, at a distance of 987.44 feet passing a 1/2 inch iron rod with "COLEMAN RPLS 4001" cap found, at a distance of 2,777.28 passing a 1/2 inch iron rod with illegible cap found for corner, at a distance of 4,527.42 feet passing a 1/2 inch iron rod with "COLEMAN RPLS 4001" cap found, continuing in all a total distance of 5,409.40 feet to 1/2 inch iron rod with "COLEMAN RPLS 4001" cap found at the southwest corner of said Tract VI and the northwest corner of said Tract 1; said point being in the east line of that tract of land described in Special Warranty Deed to JNUDF, Ltd. as recorded in Instrument Number 2008-85490 of said Official Records;

THENCE, North 00 degrees 06 minutes 11 seconds East, with the west line of said Tract VI and with the east line of said JNUDF tract, a distance of 1,051.11 feet to a wood fence corner post found at the northwest corner of said Tract VI; said point being in the south line of that tract of land described as Tract 10 in Special Warranty Deed to Trustee of the Mark Wallace Exempt Family Trust, et al as recorded in Instrument Number 2019-157304 of said Official Records;

THENCE, South 89 degrees 13 minutes 25 seconds East, with the north line of said Tract VI and with the south line of said Tract 10, a distance of 2,633.65 feet to a wood fence corner post found at the northeast corner of said Tract VI; said point being the southeast corner of said Tract 10; said point being in the west line of said Tract IV;

THENCE, North 00 degrees 07 minutes 19 seconds East, with the west line of said Tract IV and with the east line of said Tract 10, a distance of 2,009.39 feet to a wood fence corner post found at the northwest corner of said Tract IV; said point being in the south line of that tract of land described as Tract 11 in said Special Warranty Deed to Trustee of the Mark Wallace Exempt Family Trust;

THENCE, South 88 degrees 59 minutes 05 seconds East, with the north line of said Tract IV, a distance of 2,826.49 feet to a wood fence corner post found at the northeast corner of said Tract III; said point being in the west line of that called 43,439 acre tract of land described in Special Warranty Deed to Billie Louise Brasler as recorded in Instrument Number 2021-12751 of said Official Records;

THENCE, South 01 degrees 10 minutes 05 seconds West, with the east line of said Tract III and with the west line of said 43,439 acre tract, a distance of 2,362.40 feet to a point at the northwest corner of said Tract V; from said point a 3/8-inch iron rod found bears South 49 degrees 42 minutes West, a distance of 1.4 feet;

THENCE, with the north line of said Tract V and the south line of said 43,439 acre tract, the following three (3) courses and distances:

- North 89 degrees 41 minutes 24 seconds East, a distance of 689.40 feet to a point for corner;
- North 00 degrees 40 minutes 55 seconds West, a distance of 311.78 feet to a point for corner;
- North 89 degrees 19 minutes 09 seconds East, a distance of 1,240.70 feet to a wood fence corner post found at the northeast corner of said Tract V and the southeast corner of said 43,439 acre tract; said point being in the west line of said Tract VII;

THENCE, North 00 degrees 23 minutes 19 seconds West, with the west line of said Tract VII, a distance of 2,290.64 feet to a wood fence corner post found at the northwest corner of said Tract VI; said point being the northeast corner of that tract of land described as Tract Two in Special Warranty Deed to Peggy DeAnne Halford as recorded in Instrument Number 2021-12752 of said Official Records; said point being in the south line of said F.M. 1384;

THENCE, with the north line of said Tract VII and the south line of said F.M. 1384, the following five (5) calls:

- South 89° 43' 00" East, a distance of 919.41 feet to a point for corner;
- South 89° 59' 10" East, a distance of 1,874.35 feet to a point for corner at the beginning of a tangent curve to the right;
- In a southeasterly direction, with said curve to the right, an arc length of 177.93 feet, having a radius of 911.89 feet, a central angle of 11° 10' 47"; and a chord which bears South 84° 23' 56" East, 177.65 feet to a point for corner;
- South 78° 48' 32" East, a distance of 700.66 feet to a 1/2-inch iron with "OVEN 5560" cap found for corner at the beginning of a tangent curve to the left;
- In a southeasterly direction, with said curve to the left, an arc length of 44.41 feet, having a radius of 748.85 feet, a central angle of 03° 23' 36"; and a chord which bears South 80° 30' 20" East, 44.40 feet to the POINT OF BEGINNING and containing an area of 570.976 acres or 24,871,702 square feet of land, more or less.

- EASEMENT NOTES FOR SCHEDULE B:**
- 10.i. Right-of-Way Agreement recorded in Instrument 94-R0045628 of the Deed Records of Denton County, Texas is blanket in nature and contains an insufficient description to locate the easement on the subject property; however, there are gas pipeline markers and gas appurtenances on the subject property as shown hereon.
 - 10.g. Right-of-Way Agreement recorded in Instrument Number 96-R0064802 of the Deed Records of Denton County, Texas affects the subject property as shown hereon.
 - 10.h. Right-of-Way Agreement recorded in Instrument Number 98-R0074674 of the Deed Records of Denton County, Texas affects the subject property as shown hereon.
 - 10.i. Right-of-Way Agreement recorded in Instrument Number 99-R0029598 of the Deed Records of Denton County, Texas is blanket in nature and contains an insufficient description to locate the easement on the subject property; however, there are gas pipeline markers and gas appurtenances on the subject property as shown hereon.
 - 10.j. Right-of-Way Agreement recorded in Instrument Number 2005-149197 of the Deed Records of Denton County, Texas affects the subject property as shown hereon.
 - 10.k. Right-of-Way Agreement recorded in Instrument Number 4837, Page 1856 of the Deed Records of Denton County, Texas is blanket in nature and contains an insufficient description to locate the easement on the subject property; however, there are gas pipeline markers and gas appurtenances on the subject property as shown hereon.
 - 10.l. Right-of-Way Agreement recorded in Instrument Number 2005-149197 of the Official Records of Denton County, Texas is blanket in nature and contains an insufficient description to locate the easement on the subject property; however, there are gas pipeline markers and gas appurtenances on the subject property as shown hereon.
 - 10.m. Easement and Right-of-Way recorded in Instrument Number 2006-106037 of the Official Records of Denton County, Texas affects the subject property as shown hereon.
 - 10.n. Right-of-Way Agreement recorded in Instrument Number 2007-1005 of the Official Records of Denton County, Texas affects the subject property as shown hereon.
 - 10.o. Right-of-Way Agreement recorded in Instrument Number 2007-22528 of the Official Records of Denton County, Texas affects the subject property as shown hereon.
 - 10.q. Due to a vague description contained in Right-of-Way Agreement recorded in Instrument Number 2008-118586 of the Official Records of Denton County, Texas, the surveyor cannot locate the easement on the subject property; however, there are gas pipeline markers and gas appurtenances on the subject property as shown hereon.
 - 10.r. Right-of-Way Agreement recorded in Instrument Number 2008-128064 of the Official Records of Denton County, Texas affects the subject property as shown hereon.
 - 10.s. Right of Way Agreement recorded in Instrument Number 94-R0021053 of the Deed Records of Denton County, Texas is blanket in nature and contains an insufficient description to locate the easement on the subject property; however, there are gas pipeline markers and gas appurtenances on the subject property as shown hereon.
 - 10.u. Grant of Easement recorded in Instrument Number 2009-29758 of the Official Public Records of Denton County, Texas affects the subject property as shown hereon.
 - 10.v. Judgment recorded in Instrument Number 2012-34816 of the Official Public Records of Denton County, Texas affects the subject property as shown hereon.
 - 10.w. Due to a vague description contained in Right of Way Agreement recorded in Instrument Number 2011-101556 of the Official Public Records of Denton County, Texas, the surveyor cannot locate the easement on the subject property; however, there are gas pipeline markers and gas appurtenances on the subject property as shown hereon.

ALTANS/SPS LAND TITLE SURVEY
570.976 ACRES
 BEING SITUATED IN THE
 WILLIAM C. HARRISON SURVEY, ABSTRACT NO. 523,
 M.E.P.&P. R.R. CO. SURVEY, ABSTRACT NO. 908,
 WILLIAM REED SURVEY, ABSTRACT NO. 1071,
 JOSEPH SUTTON SURVEY, ABSTRACT NO. 1151,
 S.F. REYNOLDS SURVEY, ABSTRACT NO. 1627,
 DENTON COUNTY, TEXAS
 JUNE 21, 2021
 SHEET 2 OF 2

CLIENT
ASTRA DEVELOPMENT
 3625 Hall Street, Suite 720
 Dallas, Texas 75219

SURVEYOR
BGE, Inc.
 777 Main Street, Suite 1900, Fort Worth, TX 76102
 Tel: 817-857-6130 • www.bgeinc.com
 TBPLS Registration No. 10194416
 Contact: Renee Silvas, R.P.L.S.
 Telephone: (817) 752-4183 • Email: rsilvas@bgeinc.com

G:\TXM\Projects\Astra_Development\9921-05-Oliver_Creek_Ranch_ALTA_Survey\9921-05_ALTA.dwg 2021-12-10 10:14:42 rslvas

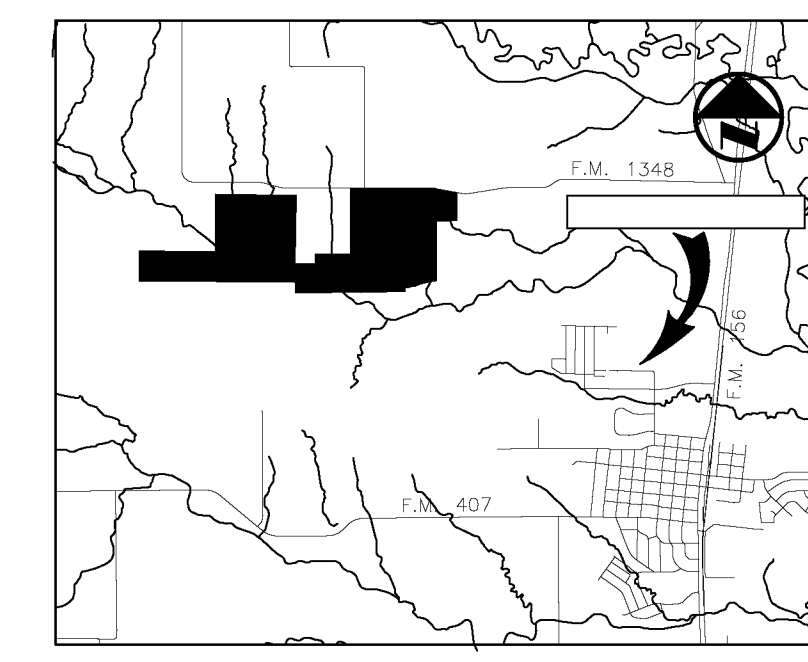

VICINITY MAP (NOT TO SCALE)

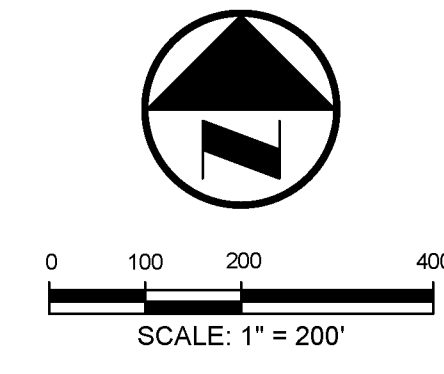

LEGEND

- 5/8-INCH IRON ROD W/ "BGE" CAP SET
- MONUMENT OF RECORD DIGNITY
- OFFICIAL PUBLIC RECORDS, DENTON COUNTY, TEXAS
- O.R.D.C.T.
- D.R.D.C.T.
- DEED RECORDS, DENTON COUNTY, TEXAS
- INST. INSTRUMENT
- VOL. VOLUME
- NO. NUMBER
- PG. PAGE
- P.O.B. POINT OF BEGINNING
- PROPERTY LINE
- EASEMENT LINE
- ABSTRACT LINE
- FLOODPLAIN LINE

GENERAL NOTES

1. Bearing system for this survey is based on the Texas State Plane Coordinate System - NAD 83, North Central Zone 4202, based on observations made on June 3, 2021 with an applied combined scale factor of 1.0001063.
2. The floodplain boundaries shown hereon are approximate and are not depicted as a result of an on-the-ground survey. The subject tract lies with Zone X and Zone A as delineated on Flood Insurance Rate Map for Denton County, Texas and Incorporated Areas, Map Number 48121C04803 with Map Revised April 18, 2011.
Zone X - Areas determined to be outside the 0.2% annual chance floodplain
Zone A - No base flood elevations determined
3. This survey was prepared with the aid of a title commitment. A thorough search of county public deed records was performed for encumbrances, rights-of-way, limitations, restrictions, or encumbrances. The surveyor did not abstract the property and any valid claim that may affect, restrict, or otherwise encumber subject tract not found or shown hereon shall not create liability on the part of the Surveyor. This survey was made relying upon that certain commitment for title insurance issued by Fidelity National Title Insurance Company under G.F. number 780002298, effective date of November 28, 2021 and issued date of December 9, 2021.
4. The square footage value shown hereon is a mathematical value calculated from the boundary data shown hereon. This value in no way represents the precision of closure of this survey or the accuracy of corner monuments found or placed.
5. Fences depicted hereon are based on locations measured in the field; the dimensions less shown are at those particular locations labeled only; the fence lines may meander between said measured locations.
6. Oliver Creek shown on this survey based on publicly available aerial photography in accordance with Table A, Item 15.
7. There appear to be apparent gas line and gas appurtenance encroachments in multiple locations across the subject property. However, there are also multiple easements that are blanket in nature that may cover these.

SURVEYOR'S CERTIFICATE

To: Astra Investments II, LLC,
Denton Oliver Creek, LP,
Glenn and Louise Shoop Family Partnership, LTD,
National Title Group, LLC, and
Fidelity National Title Insurance Company.

This is to certify that this map or plat and the survey on which it is based were made in accordance with the 2021 Minimum Standard Detail Requirements for ALTA/NSPS Land Title Surveys, jointly established and adopted by ALTA and NSPS, and includes Items 2, 3, 4, 5, 13 & 15 of Table A thereof. The fieldwork was completed on June 21, 2021.

Date of Plat or Map: June 21, 2021

Rene Silvas
Rene Silvas, RPLS No. 8921

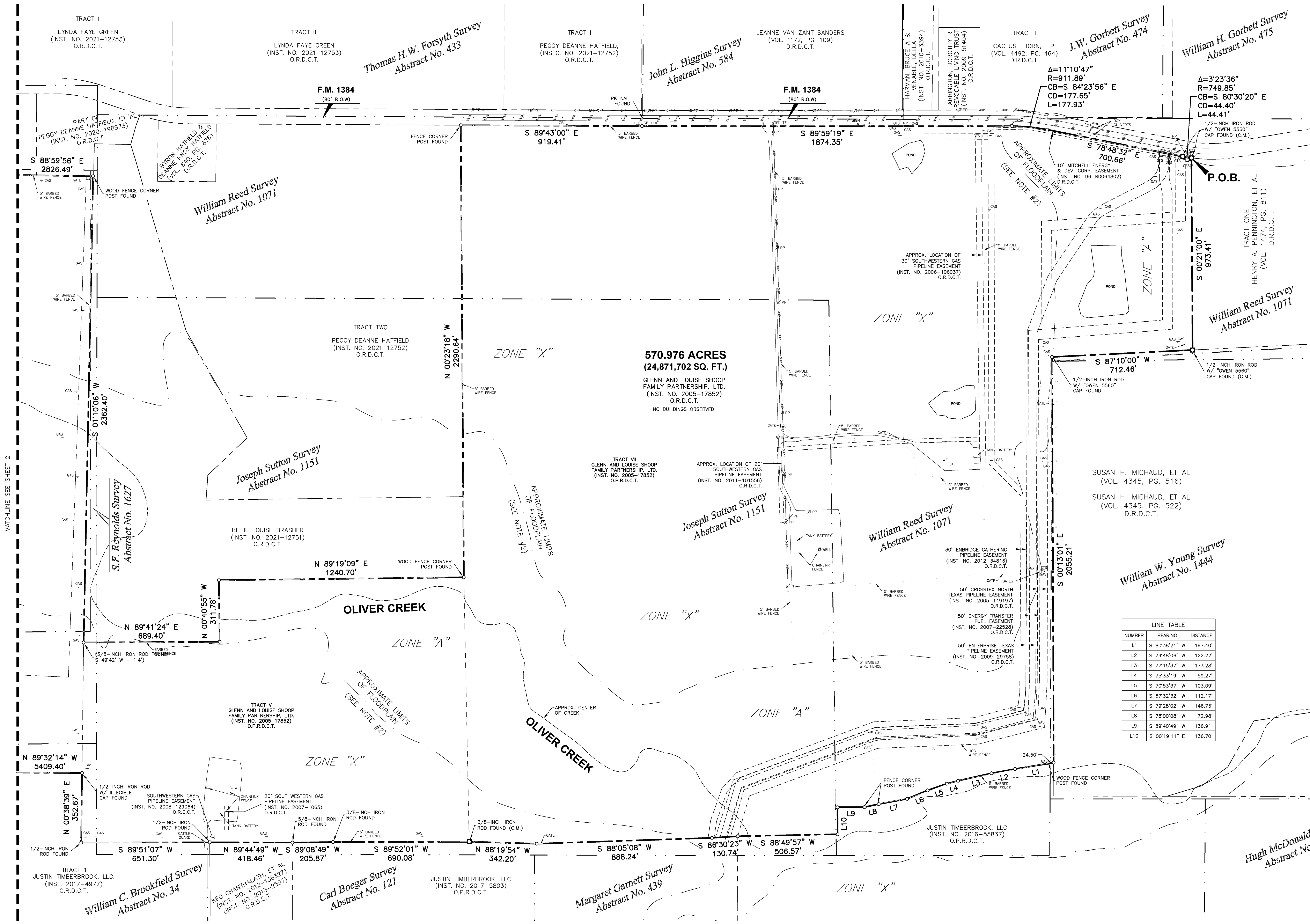

NUMBER	BEARING	DISTANCE
L1	S 80°38'21" W	197.40'
L2	S 79°48'06" W	122.22'
L3	S 77°15'37" W	173.28'
L4	S 75°33'19" W	59.27'
L5	S 70°53'37" W	103.09'
L6	S 67°32'32" W	112.17'
L7	S 79°28'02" W	146.75'
L8	S 78°00'08" W	72.98'
L9	S 89°40'49" W	136.91'
L10	S 00°19'11" E	136.70'

ALTA/NSPS LAND TITLE SURVEY
570.976 ACRES

BEING SITUATED IN THE
WILLIAM C. HARRISON SURVEY, ABSTRACT NO. 523,
M.E.P. & P. R.R. CO. SURVEY, ABSTRACT NO. 908,
WILLIAM REED SURVEY, ABSTRACT NO. 1071,
JOSEPH SUTTON SURVEY, ABSTRACT NO. 1151,
S.F. REYNOLDS SURVEY, ABSTRACT NO. 1627,
DENTON COUNTY, TEXAS

JUNE 21, 2021

SHEET 1 OF 2

CLIENT

ASTRA DEVELOPMENT
3625 Hall Street, Suite 720
Dallas, Texas 75219

SURVEYOR

BGE, Inc.
777 Main Street, Suite 1900, Fort Worth, TX 76102
Tel: 817-857-6130 • www.bgeinc.com
TBPLS Registration No. 10194416

Contact: Rene Silvas, R.P.L.S.
Telephone: (817) 752-4183 • Email: rsilvas@bgeinc.com

G:\TXM\Projects\Astra_Development\8921-05-Oliver_Creek_Ranch_ALTA_Survey\8921-05-ALTA.dwg 2021-12-10 11:38:18 (lbs)

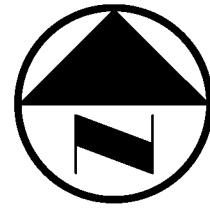

LEGEND

- C.I.R.S. 5/8-INCH IRON ROD W/ "BGE" CAP SET (C.M.) CONTROLLING MONUMENT
- O.R.D.C.T. OFFICIAL PUBLIC RECORDS, DENTON COUNTY, TEXAS
- D.R.D.C.T. DEED RECORDS, DENTON COUNTY, TEXAS
- INST. INSTRUMENT
- VOL. VOLUME
- NO. NUMBER
- PG. PAGE
- P.O.B. POINT OF BEGINNING
- PROPERTY LINE
- - - EASEMENT LINE
- ABSTRACT LINE
- - - FLOODPLAIN LINE

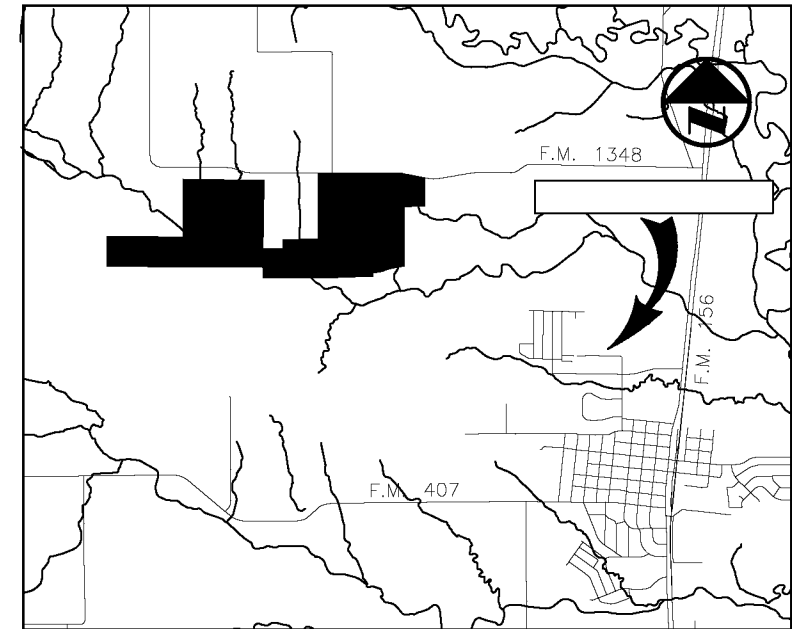

VICINITY MAP
(NOT TO SCALE)

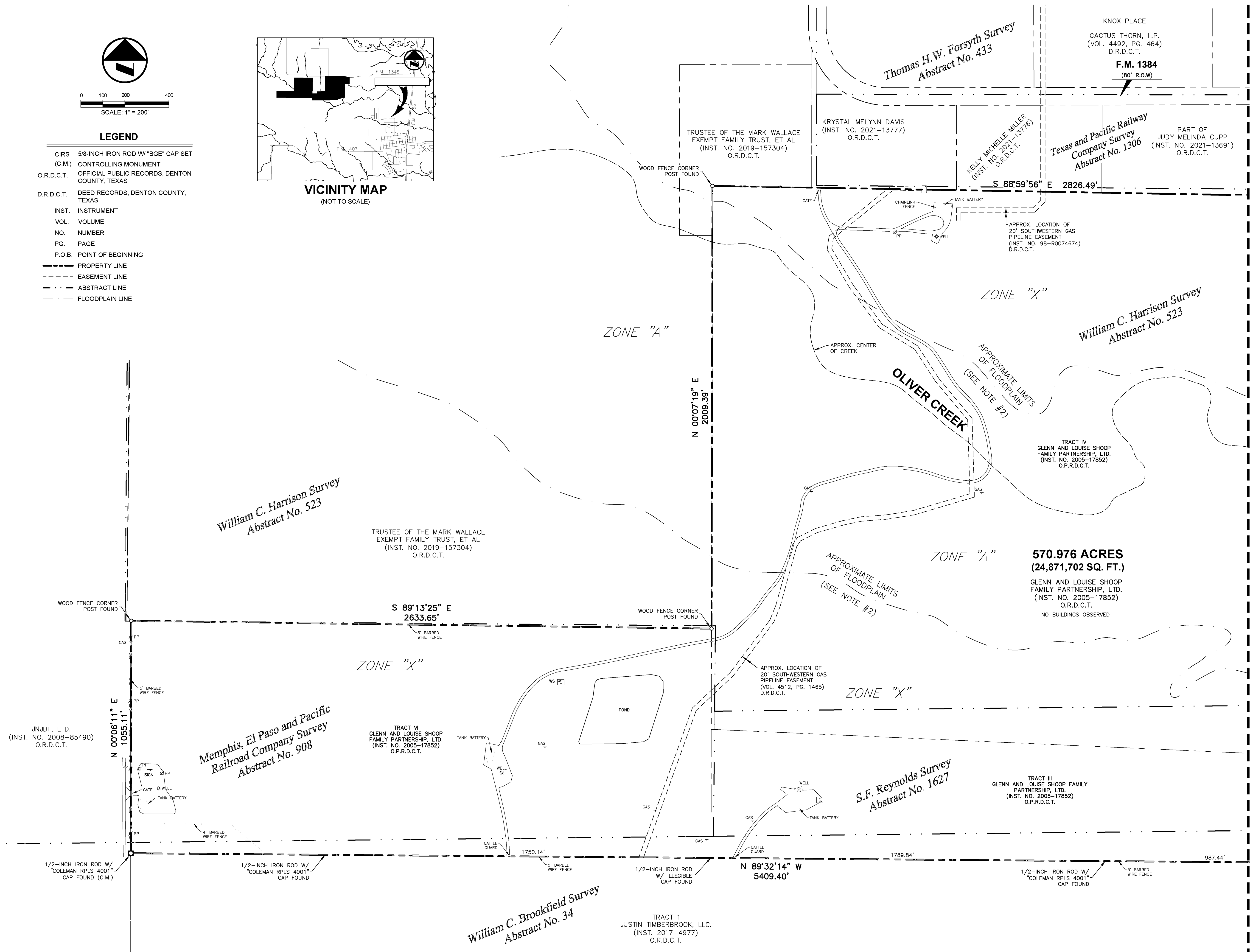

LEGAL DESCRIPTION:

BEING, all of that 570.976 acres (24,871,702 square foot) tract of land situated in the William C. Harrison Survey, Abstract Number 523, the M.E.P.&P. R.R. Co. Survey, Abstract Number 908, the William Reed Survey, Abstract Number 1071, the Joseph Sutton Survey, Abstract Number 1151, and the S.F. Reynolds Survey, Abstract Number 1627 in Denton County, Texas, being all of those tracts of land described as Tract VII, Tract VI, and Tract V in General Warranty Deed to Glenn and Louise Shoop Family Partnership, Ltd. as recorded in Instrument Number 2005-17852 of the Official Records of Denton County, Texas, said 570.976 acre tract of land being more particularly described by metes and bounds as follows:

BEGINNING, at a 1/2-inch iron with "OVEN 5560" cap found for corner in the east line of said Tract VII, said point being in the south right-of-way line of F.M. 1384 (80-foot wide right-of-way); said point being the northwest corner of that tract of land described as Tract One in Warranty Deed to Henry A. Pennington, Janice K. Coomer and Gary Michael Pennington as recorded in Volume 1474, Page 811 of the Deed Records of Denton County, Texas;

THENCE, with the east line of said Tract VII, the following three (3) courses and distances:

- South 00 degrees 21 minutes 00 seconds East, a distance of 973.41 feet to a 1/2-inch iron with "OVEN 5560" cap found for corner; said point being the southwest corner of said Pennington tract; said point being in the north line of that tract of land described in Special Warranty Deed to Susan H. Michael, et al as recorded in Volume 4345 Page 516 and Volume 4345, Page 522 of said Deed Records;
- South 87 degrees 10 minutes 00 seconds East, a distance of 712.46 feet to a 1/2-inch iron with "OVEN 5560" cap found at the northwest corner of said Michael tract;
- South 00 degrees 13 minutes 01 seconds East, with the west line of said Michael tract, a distance of 2,055.21 feet to a point at the southeast corner of said Tract VII; said point being in the north line of that called 411.268 acre tract of land described in Special Warranty Deed with Reservation of Reserved Substances to Justin Timberbrook, LLC as recorded in Instrument Number 2019-59857 of said Official Records;

THENCE, with the south line of said Tract VII and the north line of said 411.268 acre tract, the following eleven (11) courses and distances:

- South 89 degrees 38 minutes 21 seconds West, along an old barbed wire fence, at a distance of 24.5 feet passing a wood fence corner post found, continuing in all a total distance of 197.40 feet to a point for corner;
- South 79 degrees 48 minutes 06 seconds West, along said fence, a distance of 122.22 feet to a point for corner;
- South 77 degrees 15 minutes 37 seconds West, along said fence, a distance of 173.28 feet to a point for corner;
- South 75 degrees 33 minutes 19 seconds West, along said fence, a distance of 59.27 feet to a point for corner;
- South 70 degrees 53 minutes 37 seconds West, along said fence, a distance of 103.09 feet to a point for corner;
- South 67 degrees 32 minutes 32 seconds West along said fence, a distance of 112.17 feet to a point for corner;
- South 79 degrees 28 minutes 02 seconds West, along said fence, a distance of 146.75 feet to a wood fence corner post found for corner;
- South 78 degrees 00 minutes 08 seconds West, along said fence, a distance of 72.98 feet to a wood fence corner post found for corner;
- South 89 degrees 40 minutes 49 seconds West, departing said fence, a distance of 136.91 feet to a point for corner;
- South 00 degrees 19 minutes 11 seconds East, a distance of 136.70 feet to a point for corner;
- South 88 degrees 49 minutes 57 seconds West, a distance of 506.57 feet to a point at the northwest corner of said 411.268 acre tract; said point being the northeast corner of that called 241.210 acre tract of land described in Special Warranty Deed to Justin Timberbrook, LLC as recorded in Instrument Number 2017-5803 of said Official Records;

THENCE, with the south line of said Tract VII, Tract V and the north line of said 241.210 acre tract, the following five (5) courses and distances:

- South 86 degrees 30 minutes 23 seconds West, a distance of 130.74 feet to a point for corner;
- South 88 degrees 05 minutes 09 seconds West, a distance of 886.24 feet to a point for corner;
- North 88 degrees 19 minutes 54 seconds West, a distance of 342.20 feet to a 3/8 inch iron rod found for corner;
- South 89 degrees 52 minutes 01 seconds West, a distance of 690.06 feet to a 3/8 inch iron rod found for corner;
- South 89 degrees 08 minutes 49 seconds West, a distance of 205.87 feet to a 5/8 inch iron rod found at the northwest corner of said 241.210 acre tract; said point being the northeast corner of that called 18,000 acre tract of land described in General Warranty Deed to Ken Chantlath, et al as recorded in Instrument Numbers 2012-136327 and 2013-2597 of said Official Records;

THENCE, North 89 degrees 44 minutes 49 seconds West, a distance of 418.46 feet to a 1/2 inch iron rod found at the northwest corner of said 18,000 acre tract; said point being the northeast corner of that tract of land described as Tract 1 in Special Warranty Deed to Justin Timberbrook, LLC as recorded in Instrument Number 2017-4977 of said Official Records;

THENCE, with the south line of said Tract V, Tract VI and the north line of said Tract 1, the following three (3) courses and distances:

- South 89 degrees 51 minutes 07 seconds West, a distance of 651.30 feet to a 1/2 inch iron rod found for corner;
- North 00 degrees 38 minutes 39 seconds East, a distance of 352.67 feet to a 1/2 inch iron rod found for corner;
- North 89 degrees 32 minutes 14 seconds West, at a distance of 987.44 feet passing a 1/2 inch iron rod with "COLEMAN RPLS 4001" cap found, at a distance of 2,777.28 passing a 1/2 inch iron rod with illegible cap found for corner, at a distance of 4,527.42 feet passing a 1/2 inch iron rod with "COLEMAN RPLS 4001" cap found, continuing in all a total distance of 5,409.40 feet to 1/2 inch iron rod with "COLEMAN RPLS 4001" cap found at the southwest corner of said Tract VI and the northwest corner of said Tract 1; said point being in the east line of that tract of land described in Special Warranty Deed to J.N.D.F., Ltd. as recorded in Instrument Number 2008-85490 of said Official Records;

THENCE, North 00 degrees 06 minutes 11 seconds East, with the west line of said Tract VI and with the east line of said J.N.D.F. tract, a distance of 1,055.11 feet to a wood fence corner post found at the northwest corner of said Tract VI; said point being in the south line of that tract of land described as Tract 10 in Special Warranty Deed to Trustee of the Mark Wallace Exempt Family Trust, et al as recorded in Instrument Number 2019-157304 of said Official Records;

THENCE, South 89 degrees 13 minutes 25 seconds East, with the north line of said Tract VI and with the south line of said Tract 10, a distance of 2,633.65 feet to a wood fence corner post found at the northeast corner of said Tract VI; said point being the southeast corner of said Tract 10; said point being in the west line of said Tract IV;

THENCE, North 00 degrees 07 minutes 19 seconds East, with the west line of said Tract IV and with the east line of said Tract 10, a distance of 2,009.39 feet to a wood fence corner post found at the northwest corner of said Tract IV; said point being in the south line of that tract of land described as Tract 11 in said Special Warranty Deed to Trustee of the Mark Wallace Exempt Family Trust;

THENCE, South 88 degrees 59 minutes 05 seconds East, with the north line of said Tract IV, a distance of 2,826.49 feet to a wood fence corner post found at the northeast corner of said Tract III; said point being in the west line of that called 43,439 acre tract of land described in Special Warranty Deed to Billie Louise Brasler as recorded in Instrument Number 2021-12751 of said Official Records;

THENCE, South 01 degrees 10 minutes 05 seconds West, with the east line of said Tract III and with the west line of said 43,439 acre tract, a distance of 2,362.40 feet to a point at the northwest corner of said Tract V; from said point a 3/8-inch iron rod found bears South 49 degrees 42 minutes West, a distance of 1.4 feet;

THENCE, with the north line of said Tract V and the south line of said 43,439 acre tract, the following three (3) courses and distances:

- North 89 degrees 41 minutes 24 seconds East, a distance of 689.40 feet to a point for corner;
- North 00 degrees 40 minutes 55 seconds West, a distance of 311.78 feet to a point for corner;
- North 89 degrees 19 minutes 09 seconds East, a distance of 1,240.70 feet to a wood fence corner post found at the northeast corner of said Tract V and the southeast corner of said 43,439 acre tract; said point being in the west line of said Tract VII;

THENCE, North 00 degrees 23 minutes 19 seconds West, with the west line of said Tract VII, a distance of 2,290.64 feet to a wood fence corner post found at the northwest corner of said Tract VI; said point being the northeast corner of that tract of land described as Tract Two in Special Warranty Deed to Peggy DeAnne Halford as recorded in Instrument Number 2021-12752 of said Official Records; said point being in the south line of said F.M. 1384;

THENCE, with the north line of said Tract VII and the south line of said F.M. 1384, the following five (5) calls:

- South 89° 43' 00" East, a distance of 919.41 feet to a point for corner;
- South 89° 59' 10" East, a distance of 1,874.35 feet to a point for corner at the beginning of a tangent curve to the right;
- In a southeasterly direction, with said curve to the right, an arc length of 177.93 feet, having a radius of 911.89 feet, a central angle of 11° 10' 47"; and a chord which bears South 84° 23' 56" East, 177.65 feet to a point for corner;
- South 78° 48' 32" East, a distance of 700.66 feet to a 1/2-inch iron with "OVEN 5560" cap found for corner at the beginning of a tangent curve to the left;
- In a southeasterly direction, with said curve to the left, an arc length of 44.41 feet, having a radius of 749.85 feet, a central angle of 03° 23' 36"; and a chord which bears South 80° 30' 20" East, 44.40 feet to the POINT OF BEGINNING and containing an area of 570.976 acres or 24,871,702 square feet of land, more or less.

- EASEMENT NOTES FOR SCHEDULE B:**
- 10.i. Right-of-way Agreement recorded in Instrument 94-R0045628 of the Deed Records of Denton County, Texas is blanket in nature and contains an insufficient description to locate the easement on the subject property; however, there are gas pipeline markers and gas appurtenances on the subject property as shown hereon.
 - 10.g. Right-of-way Agreement recorded in Instrument Number 96-R0064802 of the Deed Records of Denton County, Texas affects the subject property as shown hereon.
 - 10.h. Right-of-way Agreement recorded in Instrument Number 98-R0074674 of the Deed Records of Denton County, Texas affects the subject property as shown hereon.
 - 10.i. Right-of-way Agreement recorded in Instrument Number 99-R0029598 of the Deed Records of Denton County, Texas is blanket in nature and contains an insufficient description to locate the easement on the subject property; however, there are gas pipeline markers and gas appurtenances on the subject property as shown hereon.
 - 10.j. Right-of-way Agreement recorded in Instrument Number 2005-149197 of the Deed Records of Denton County, Texas affects the subject property as shown hereon.
 - 10.k. Right-of-way Agreement recorded in Instrument Number 4837, Page 1856 of the Deed Records of Denton County, Texas is blanket in nature and contains an insufficient description to locate the easement on the subject property; however, there are gas pipeline markers and gas appurtenances on the subject property as shown hereon.
 - 10.l. Right-of-way Agreement recorded in Volume 4878, Page 100 of the Deed Records of Denton County, Texas is blanket in nature and contains an insufficient description to locate the easement on the subject property; however, there are gas pipeline markers and gas appurtenances on the subject property as shown hereon.
 - 10.m. Easement and Right-of-Way recorded in Instrument Number 2005-149197 of the Official Records of Denton County, Texas affects the subject property as shown hereon.
 - 10.n. Right-of-Way Agreement recorded in Instrument Number 2006-106037 of the Official Records of Denton County, Texas affects the subject property as shown hereon.
 - 10.o. Right-of-Way Agreement recorded in Instrument Number 2007-1005 of the Official Records of Denton County, Texas affects the subject property as shown hereon.
 - 10.p. Easement and Right-of-Way recorded in Instrument Number 2007-22528 of the Official Records of Denton County, Texas affects the subject property as shown hereon.
 - 10.q. Due to a vague description contained in Right-of-Way Agreement recorded in Instrument Number 2008-118586 of the Official Records of Denton County, Texas, the surveyor cannot locate the easement on the subject property; however, there are gas pipeline markers and gas appurtenances on the subject property as shown hereon.
 - 10.r. Right-of-Way Agreement recorded in Instrument Number 2008-129064 of the Official Records of Denton County, Texas affects the subject property as shown hereon.
 - 10.s. Right of Way Agreement recorded in Instrument Number 94-R0021053 of the Deed Records of Denton County, Texas is blanket in nature and contains an insufficient description to locate the easement on the subject property; however, there are gas pipeline markers and gas appurtenances on the subject property as shown hereon.
 - 10.u. Grant of Easement recorded in Instrument Number 2009-29758 of the Official Public Records of Denton County, Texas affects the subject property as shown hereon.
 - 10.v. Judgment recorded in Instrument Number 2012-34816 of the Official Public Records of Denton County, Texas affects the subject property as shown hereon.
 - 10.w. Due to a vague description contained in Right of Way Agreement recorded in Instrument Number 2011-101556 of the Official Public Records of Denton County, Texas, the surveyor cannot locate the easement on the subject property; however, there are gas pipeline markers and gas appurtenances on the subject property as shown hereon.

ALTANS/SPS LAND TITLE SURVEY
570.976 ACRES
 BEING SITUATED IN THE
 WILLIAM C. HARRISON SURVEY, ABSTRACT NO. 523,
 M.E.P.&P. R.R. CO. SURVEY, ABSTRACT NO. 908,
 WILLIAM REED SURVEY, ABSTRACT NO. 1071,
 JOSEPH SUTTON SURVEY, ABSTRACT NO. 1151,
 S.F. REYNOLDS SURVEY, ABSTRACT NO. 1627,
 DENTON COUNTY, TEXAS
 JUNE 21, 2021
 SHEET 2 OF 2

CLIENT
ASTRA DEVELOPMENT
 3625 Hall Street, Suite 720
 Dallas, Texas 75219

SURVEYOR
BGE, Inc.
 777 Main Street, Suite 1900, Fort Worth, TX 76102
 Tel: 817-857-6130 • www.bgeinc.com
 TBPLS Registration No. 10194416
 Contact: Renee Silvas, R.P.L.S.
 Telephone: (817) 752-4183 • Email: rsilvas@bgeinc.com

G:\TXM\Projects\Astra Development\8921-05-Oliver Creek Branch, ALTA, Survey\8921-05 ALTA.dwg 2021-12-10 10:14:42 rslvas