

Control Number: 35077



Item Number: 925

Addendum StartPage: 0

35077

RECEIVED

2019 MAR -1 PM 3:01

PUBLIC UTILITY COMMISSION
FILING CLERK

**FIRST AMENDED AND RESTATED
INTERCONNECTION AGREEMENT
BETWEEN
ELECTRIC TRANSMISSION TEXAS, LLC
AND
SHARYLAND UTILITIES, L.P.**

DATED: 2/28/2019 | 2:53 PM CST

925

**FIRST AMENDED AND RESTATED
INTERCONNECTION AGREEMENT
BETWEEN
ELECTRIC TRANSMISSION TEXAS, LLC
AND
SHARYLAND UTILITIES, L.P.**

This **First Amended and Restated Interconnection Agreement** (“Agreement”) is made and entered into as of 2/28/2019 | 2:53 PM CST (the “Execution Date”), by and between **Electric Transmission Texas, LLC** (“ETT”) and **Sharyland Utilities, L.P.** (“SU”) each sometimes hereinafter referred to individually as a “Party” or both referred to collectively as the “Parties.”

WITNESSETH

WHEREAS, each Party is the owner and operator of transmission facilities and is engaged in the business of transmitting electric energy to the general public within the ERCOT; and

WHEREAS, ETT and SU entered into that certain Interconnection Agreement executed as of July 28, 2016 (“Original Agreement”); and

WHEREAS, SU and Oncor Electric Delivery Company LLC (“Oncor”) have consummated transactions contemplated by that certain Agreement and Plan of Merger, dated as of July 21, 2017, by and among SU and Oncor and certain of their affiliates pursuant to which certain electric transmission and distribution assets have been transferred between the parties to that agreement (“2017 Asset Transfer”); and

WHEREAS, in order to reflect the effect of the 2017 Asset Transfer, which resulted in additional points of interconnection between ETT and SU, the Parties agree to amend and restate the Original Agreement to (1) add new Facility Schedule No. 2 Riley via the 2017 Asset Transfer; and (2) add new Facility Schedule No. 3 Clear Crossing via the 2017 Asset Transfer; and

WHEREAS, the Parties desire to amend and restate the Original Agreement to reflect the changes described in the previous paragraphs and to make certain other changes; and

WHEREAS, the Parties desire to interconnect their respective transmission systems in the respects, and under the terms and conditions set forth below.

NOW, THEREFORE, in consideration of the premises and of the mutual covenants and conditions herein set forth, the Parties agree as follows:

ARTICLE I – EFFECTIVE DATE AND TERM

1.1 This Agreement and all obligations hereunder, are expressly conditioned upon obtaining (without conditions, limitations or qualifications that are unacceptable to either Party) approval or authorization or acceptance for filing by any regulatory authority whose approval,

authorization or acceptance for filing is required by law. After execution by both Parties, ETT will file this Agreement with the PUCT. Both Parties hereby agree to support the approval of this Agreement before such regulatory authorities and to provide such documents, information, and opinions as may be reasonably required or requested by either Party in the course of approval proceedings.

1.2 Subject to Section 1.1, this Agreement shall become effective on the Execution Date (the “Effective Date”).

1.3 Unless otherwise mutually agreed, this Agreement shall remain in effect for a period of five (5) years from the Effective Date, and shall continue in effect thereafter for periods of two (2) years each unless canceled by either mutual agreement or by either Party upon at least twenty-four (24) months written notice to the other Party. Upon termination of this Agreement, each Party shall discontinue the use of the facilities of the other and shall disconnect the Points of Interconnection.

ARTICLE II – OBJECTIVE AND SCOPE

2.1 It is the intent of the Parties, by this Agreement, to state the terms and conditions under which the Parties’ transmission systems will be interconnected and to identify the facilities provided by each Party at the Points of Interconnection.

2.2 This Agreement shall apply to the ownership, construction, operation, and maintenance of those facilities that are specifically identified and described in the Facility Schedules that are attached hereto and incorporated herein. This Agreement does not obligate either Party to provide, or entitle either Party to receive, any service not expressly provided for herein. Each Party is responsible for making the arrangements necessary to receive any delivery service, ancillary service or other miscellaneous service that either Party may desire from the other Party or any third party.

2.3 This Agreement, including all attached Facility Schedules, constitutes the entire agreement and understanding between the Parties with regard to the interconnection of the facilities of the Parties at the Points of Interconnection expressly provided for in this Agreement; provided, however, the Parties acknowledge that in some cases they may enter into separate agreements regarding the construction, repair, upgrade, or demolition of certain facilities as contemplated by Section 4.4. The Parties are not bound by or liable for any statement, representation, promise, inducement, understanding, or undertaking of any kind or nature (whether written or oral) with regard to the subject matter hereof if not set forth or provided for herein. This Agreement replaces and supersedes all other agreements and undertakings, oral and written, between the Parties with regard to the subject matter hereof. It is expressly acknowledged that the Parties may have other agreements covering other services not expressly provided for herein; such agreements are unaffected by this Agreement.

ARTICLE III – DEFINITIONS

For purposes of this Agreement, the following definitions shall apply:

3.1 Agreement means this First Amended and Restated Interconnection Agreement with all exhibits, schedules and attachments applying hereto, including any schedules and attachments hereafter made and any amendments hereafter made.

3.2 ERCOT means the Electric Reliability Council of Texas, Inc., or its successor in function.

3.3 ERCOT Requirements means the ERCOT Nodal Operating Guides and ERCOT Nodal Protocols adopted by ERCOT and approved by the PUCT, including any attachments or exhibits referenced in the ERCOT Nodal Protocols, as amended from time to time, that contain the scheduling, operating, planning, reliability, and settlement (including customer registration) policies, rules, guidelines, procedures, standards, and criteria of ERCOT.

3.4 Facility Schedule(s) means the schedule(s) to this Agreement that identify the Point(s) of Interconnection and describe the agreement on ownership, control, operation, and maintenance responsibilities of the Parties at the Point(s) of Interconnection.

3.5 Good Utility Practice shall have the meaning described in the PUCT Rule 25.5 or its successor.

3.6 NERC means the North American Electric Reliability Corporation or its successor electric reliability organization.

3.7 NERC Reliability Standards means the mandatory electric reliability standards established and enforced by NERC.

3.8 Point(s) of Interconnection means the points where the Systems of the Parties are connected or may, by the closure of normally open switches, be connected.

3.9 PUCT means the Public Utility Commission of Texas or its successor in function.

3.10 System means the electrical transmission and/or distribution facilities and equipment of either Party.

ARTICLE IV – ESTABLISHMENT AND TERMINATION OF POINTS OF INTERCONNECTION

4.1 The Parties shall comply with any applicable NERC Reliability Standards that relate to the interconnection of their facilities at the locations identified and described in the Facility Schedules. Each Party shall provide to the other Party all information that may reasonably be required by the other Party to comply with NERC Reliability Standards, if any. Notwithstanding the foregoing, a Party shall not be required to disclose information which it deems confidential unless the Parties execute a confidentiality agreement to protect the confidential nature of such information.

4.2 The Parties agree to interconnect their facilities at the locations specified in Exhibit A and in accordance with the terms and conditions specified in this Agreement and as further described in the Facility Schedule(s). The Facility Schedule(s) shall specify the responsibilities of the Parties with respect to ownership, control, operation, and maintenance of the interconnection facilities.

4.3 Unless otherwise provided in a Facility Schedule, each Party shall, at each Point of Interconnection, at its own risk and expense, design, install, or cause the design and installation of the transmission or distribution facilities (including all apparatus and necessary protective devices) on its side of the Point of Interconnection, so as to reasonably minimize the likelihood of voltage and frequency abnormalities, originating in the System of one Party, from affecting or impairing the System of the other Party, or other electrical systems to which the System of such Party is interconnected. The Parties agree that all Points of Interconnection will be established in conformance with the ERCOT Requirements. The Parties agree to cause their Systems to be constructed in accordance with specifications at least equal to those provided by the National Electrical Safety Code, approved by the American National Standards Institute, in effect at the time of construction. Except as otherwise provided in the Facility Schedules, each Party will be responsible for the facilities it owns on its side of the Point of Interconnection.

4.4 From time to time, a Point of Interconnection may be added, changed, modified, or deleted from this Agreement as mutually agreed by the Parties and/or as ordered by a regulatory authority having jurisdiction thereof. The Parties shall enter into such agreements as the Parties mutually agree to address any related construction, repair, upgrade, or demolition activities. In addition, the Parties shall amend this Agreement to update Exhibit A and to update Facility Schedules or add new Facility Schedules, as applicable. Subject to regulatory approval, if required, either Party may terminate a Point of Interconnection on twelve (12) months advance written notice. Upon termination of a Point of Interconnection, each Party shall discontinue the use of the facilities of the other Party associated with the use of that Point of Interconnection and shall disconnect from that Point of Interconnection. The Parties agree to use reasonable efforts to coordinate the termination of a Point of Interconnection to minimize any disruption in service by either Party.

4.5 Subject to regulatory approval, if required, and unless otherwise mutually agreed, neither Party shall have the right to disconnect from the other Party at any Point of Interconnection specified on Exhibit A and a Facility Schedule, originally attached to this Agreement or added subsequent to the execution of this Agreement, except as set forth in Section 4.4 above, or upon failure to cure a Default pursuant to Article XIV of this Agreement.

4.6 For facilities not specified in the Facility Schedules, or if either Party makes changes or additions to the facilities at a Point of Interconnection, which may affect the operation or performance of the other Party's interconnection facilities, the Parties agree to notify the other Party, in writing, of such changes. Such changes shall be made in accordance with Good Utility Practice, ERCOT Requirements, the National Electrical Safety Code, other applicable codes, and standards in effect at the time of construction, and coordinated between the Parties.

4.7 Each Party agrees to provide current as-built drawings to the other Party of the facilities owned by that Party at each Point of Interconnection.

4.8 The Parties agree to coordinate and cooperate on assessments of the reliability impacts to their interconnected Systems for new facilities requesting connection to their Systems, in accordance with any applicable NERC Reliability Standards.

ARTICLE V - SYSTEM OPERATION AND MAINTENANCE

5.1 Unless otherwise provided by the Facility Schedules, each Party shall, at each Point of Interconnection, at its own risk and expense, operate and maintain the facilities (including all apparatus and necessary protective devices) it owns or hereafter may own, so as to reasonably minimize the likelihood of voltage and frequency abnormalities, originating in the System of one Party, from affecting or impairing the System of the other Party, or other electrical systems to which the Party is interconnected. The Parties agree that all Points of Interconnection will be operated and maintained in conformance with the ERCOT Requirements and Good Utility Practice.

5.2 Unless otherwise provided by the Facility Schedules, each Party, at its sole cost and expense, will be responsible for the operation, maintenance and inspection of all facilities it owns now or hereafter may own associated with each Point of Interconnection.

5.3 Unless otherwise provided by the Facility Schedules, each Party shall operate the facilities within its System. The operation of the System shall be such that power flows that enter and exit one Party's System do not have undue impacts on the other Party's System. Operational responsibility for facilities owned by one Party, but installed in another Party's substation or transmission line will be identified in the Facility Schedule for that particular Point of Interconnection.

5.4 During the term of this Agreement, the Parties will, consistent with Good Utility Practice, coordinate their operations to maintain continuity of services to their respective customers to the extent practicable. Planned facility maintenance by either Party that will cause a deviation from the normal power and energy flow at a Point of Interconnection will be scheduled at a mutually agreeable time. Except as otherwise permitted by the terms of this Agreement, no changes will be made in the normal operation of a Point of Interconnection without the mutual agreement of the Parties. The Parties will, to the extent necessary to support continuity of operations, coordinate the operation of protective devices on the facilities they operate in the proximity of the Points of Interconnection that might reasonably be expected to affect the operation of facilities on the other Party's System.

5.5 Each Party will provide the reactive requirements for its own System in accordance with the ERCOT Requirements. Each Party will provide the reactive requirements for its own System so as not to impose a burden on the other Party's System.

5.6 During periods of emergency conditions declared by ERCOT, or as necessary to restore customer service, either Party may operate equipment that is normally operated by the other Party, provided that authorization to do so must first be received from the Party that normally operates the equipment, such authorization not to be unreasonably withheld or delayed. It shall be considered reasonable for the Party that normally operates such equipment to deny such a request by the other Party if the withholding Party will provide such operation within the time frame called

for in the circumstances. Such operations by the other Party will be at no cost to the owner or normal operator of the equipment.

5.7 Each Party will determine the operating limits of the facilities that it owns and make such limits known to the other Party. The Party operating those facilities will operate within those limits in accordance with NERC and ERCOT requirements.

5.8 Unless otherwise provided in a Facility Schedule, for purposes of ERCOT under-frequency, under-voltage or emergency load shedding program requirements, the Parties agree that each Party will be obligated to communicate with ERCOT and account for the loads associated with the distribution breaker and feeder that it operates.

ARTICLE VI - RIGHTS OF ACCESS, EQUIPMENT INSTALLATION, AND REMOVAL

6.1 Each Party shall permit duly authorized representatives and employees of the other Party to enter upon its premises, with timely prior notice, for the purpose of inspecting, testing, repairing, renewing, or exchanging any or all of the equipment owned by such other Party that is located on such premises or for the purpose of performing any work necessary in the performance of this Agreement.

6.2 Each Party grants to the other Party permission to install, maintain, and/or operate, or cause to be installed, maintained, and/or operated, on its premises, the necessary equipment, apparatus, and devices required for the performance of this Agreement. Any such installation, maintenance, and operation to be performed, except in the case of emergencies, shall be performed only after a schedule of such activity has been submitted and agreed upon by the Parties.

6.3 Unless otherwise agreed in writing, any and all facilities placed or installed, or caused to be placed or installed by one Party on, or in, the premises of the other Party, shall be owned by and remain the property of the Party installing such facilities, regardless of the mode and manner of annexation or attachment to real property. Upon the termination of any Point of Interconnection under this Agreement, the Party owning such facilities placed or installed on the premises of the other Party, shall have the right 1) to sell such facilities to the other Party, if the other Party wishes to purchase such facilities, or 2) to enter the premises of the other Party and, within a reasonable time, remove such facilities, at no cost to the owner of the premises. If, upon the termination of any Point of Interconnection under this Agreement, facilities of a Party that are installed on the premises of the other Party are neither sold to the other Party nor removed by the owning Party within a reasonable time, such facilities shall be considered abandoned by the owning Party and may be disposed of by the other Party in the manner it shall determine appropriate; provided, however, that any net cost incurred by the disposing Party shall be reimbursed by the abandoning Party.

6.4 Each Party shall clearly mark their respective facilities with appropriate ownership identification.

6.5 Either Party may request the other Party to upgrade or modify its terminal facilities at a Point of Interconnection in accordance with the other Party's standard design of equipment, provided that the upgrade or modification is consistent with Good Utility Practice and, if

applicable, is approved by ERCOT. The requesting Party shall provide the other Party a minimum of twenty-four (24) months notice of the upgrade or modification of its terminal facilities at a Point of Interconnection, absent mutual acceptance of a shorter notice period. The Parties agree to use reasonable efforts to coordinate the upgrade or modification of terminal facilities at a Point of Interconnection to minimize any disruption in service by either Party.

ARTICLE VII – METERING AND RECORDS

7.1 Unless otherwise agreed in writing, all metering equipment required herein shall be selected, installed, tested, operated and maintained by the Party owning such metering equipment in accordance with Good Utility Practice and the ERCOT Requirements.

7.2 The Party that does not own the metering equipment shall be permitted to witness any testing, inspection, maintenance, or alteration of such metering equipment owned by the other Party. The owner of such equipment shall give reasonable advance notice of all tests and inspections so that representatives of the other Party may be present. After proper notification to the other Party, the owner may proceed with the scheduled tests or inspections regardless of whether a witness is present.

7.3 If any test or inspection of metering equipment shows that it does not meet the accuracy requirements established by the ERCOT Requirements, the meter or other equipment found to be inaccurate or defective shall be promptly repaired, adjusted, or replaced by the owner. Should metering equipment fail to register, the power and energy delivered and received shall be determined in accordance with the ERCOT Requirements.

7.4 As long as metering, telemetering or communications facilities are required by the ERCOT Requirements and are operated and maintained in accordance with the ERCOT Requirements, the Party owning these facilities shall allow the other Party to read the meter by means of the existing telemetering and communications facilities. The other Party shall be responsible for any incremental costs incurred by the owning Party to provide any meter reading capability over and above that which is required by the owning Party.

ARTICLE VIII – COMMUNICATION AND TELEMETERING FACILITIES

8.1 Unless otherwise agreed in writing, each Party shall provide, at its own expense, the necessary communication and telemetering facilities needed for the control and operation of its System.

8.2 All communication and telemetering facilities required herein shall be selected, installed, tested, operated, and maintained by the Party owning such equipment in accordance with Good Utility Practice and the ERCOT Requirements.

ARTICLE IX - INDEMNIFICATION

NOTWITHSTANDING THE PROVISIONS OF ARTICLE XIII, TO THE EXTENT PERMITTED BY LAW AND ONLY TO THE EXTENT RESULTING FROM A PARTY'S NEGLIGENCE OR OTHER FAULT IN THE DESIGN, CONSTRUCTION, OR OPERATION OF ITS FACILITIES DURING THE PERFORMANCE OF THIS

AGREEMENT, SUCH PARTY SHALL (I) ASSUME ALL LIABILITY FOR, AND SHALL INDEMNIFY THE OTHER PARTY AGAINST, ANY AND ALL MONETARY LOSSES SUFFERED BY THE OTHER PARTY OR DAMAGE TO SUCH OTHER PARTY'S PROPERTY, AND (II) INDEMNIFY THE OTHER PARTY AND ITS DIRECTORS, OFFICERS, EMPLOYEES, AND AGENTS AGAINST THIRD PERSONS' CLAIMS (AND SUCH INDEMNIFIED PERSON'S COSTS AND EXPENSES OF DEFENSE THEREOF) FOR INJURY TO OR DEATH OF ANY PERSON, DAMAGE TO PROPERTY OF ANY THIRD PERSON, OR DISRUPTION OF THE BUSINESS OF ANY THIRD PERSON. NOTHING IN THIS ARTICLE WILL CREATE AN OBLIGATION TO ASSUME, OR INDEMNIFY A PERSON FOR, (I) A PARTY'S COSTS AND EXPENSES, COURT COSTS, OR ATTORNEY FEES INCURRED IN PROSECUTING OR DEFENDING AN ACTION AGAINST THE OTHER PARTY, OR (II) DAMAGES FOR DISRUPTION OF THE OTHER PARTY'S BUSINESS, OR (III) AMOUNTS PAID BY THE OTHER PARTY IN SETTLEMENT OF CLAIMS; PROVIDED, HOWEVER, THAT THE LIMITATIONS OF LIABILITY SET FORTH IN (I) AND (II) SHALL NOT APPLY TO AN INDEMNIFYING PARTY'S GROSS NEGLIGENCE OR INTENTIONAL MISCONDUCT AND THE LIMITATION OF LIABILITY SET FORTH IN (I) SHALL NOT NEGATE ANY OBLIGATION TO PAY FOR SUCH COSTS UNDER CHAPTER 38 OF THE TEXAS CIVIL PRACTICE & REMEDIES CODE OR OTHER APPLICABLE STATUTES. THIS ARTICLE DOES NOT CREATE A LIABILITY ON THE PART OF EITHER PARTY TO A THIRD PERSON, BUT REQUIRES INDEMNIFICATION TO THE EXTENT SET FORTH HEREIN WHERE SUCH LIABILITY EXISTS. THIS ARTICLE WILL NOT BE APPLIED TO CREATE AN INDEMNIFICATION OBLIGATION THAT IS IN EXCESS OF ANY CONTRIBUTION OBLIGATION A PARTY HAS UNDER CHAPTER 33 OF THE TEXAS CIVIL PRACTICE & REMEDIES CODE.

ARTICLE X – NOTICES

10.1 Notices of an administrative nature, including but not limited to a notice of termination, notice of default, request for amendment, change to a Point of Interconnection, or request for a new Point of Interconnection, shall be forwarded to the designees listed below for each Party and shall be deemed properly given if delivered in writing in the manner described herein. Any such notice may be given by personal delivery to the Party entitled thereto by e-mail (with confirmation of receipt), by any courier service which guarantees overnight, receipted delivery, or by U.S. Certified or Registered Mail, return receipt requested, addressed to the Party entitled thereto, at:

If to ETT:

Electric Transmission Texas, LLC
Leo L. York, Vice President
400 W. 15th Street, Suite 800
Austin, Texas 78701-1677
512-391-6310
llyork@aep.com

With copy to:

Electric Transmission Texas, LLC
c/o American Electric Power Service Corporation
Director, System Interconnections
Robert Pennybaker
212 E. 6th Street
Tulsa, Oklahoma 74119
918-599-2723
rlpennybaker@aep.com

If to SU:

Sharyland Utilities, L.P.
Attention: Legal
1900 N. Akard Street
Dallas, Texas 75201
Tele: (214) 978-8958
kelly.frazier@sharyland.com

With copy to:

Sharyland Utilities, L.P.
Attention: Greg Boggs, Senior Vice President
6900 Interstate 40 West, Suite 100
Amarillo, Texas 79106
Tele: (806) 358-9070
greg.boggs@sharyland.com

10.2 The above listed names, titles, and addresses of either Party may be changed upon written notification to the other Party.

ARTICLE XI - SUCCESSORS AND ASSIGNS

11.1 Subject to the provisions of Section 11.2 below, this Agreement shall be binding upon and inure to the benefit of the permitted successors and assigns of the respective Parties.

11.2 Neither Party shall assign its interest in this Agreement in whole or in part without the prior written consent of the other Party. Such consent shall not be unreasonably withheld, provided that neither Party will be required to consent to any assignment which would, in its sole judgment and among other reasons, subject it to additional federal or state regulation, result in the imposition of additional costs of administration which the Party requesting consent to assignment does not agree to reimburse, or in any way diminish the reliability of its System, enlarge its obligations or otherwise create or maintain an unacceptable condition. The respective obligations of the Parties under this Agreement may not be changed, modified, amended, or enlarged, in whole or in part, by reason of the sale, merger, or other business combination of either Party with any

other person or entity. Notwithstanding the foregoing, a Party may assign, without the consent of the other Party, its interest in this Agreement, in whole or in part, to a successor to all or a substantial portion of the Party's transmission and distribution business; to any affiliate of the assigning Party with an equal or greater credit rating; to any transmission service provider with the legal authority and operational ability to satisfy the obligations of the assigning Party under this Agreement; or for collateral security purposes in connection with any financing or financial arrangements.

11.3 The several provisions of this Agreement are not intended to and shall not create rights of any character whatsoever in favor of any persons, corporations, or associations other than the Parties to this Agreement, and the obligations herein assumed are solely for the use and benefit of the Parties to this Agreement.

ARTICLE XII – GOVERNING LAW AND REGULATION

12.1 **THIS AGREEMENT SHALL IN ALL RESPECTS BE GOVERNED BY, INTERPRETED, CONSTRUED, AND ENFORCED IN ACCORDANCE WITH THE LAWS OF THE STATE OF TEXAS EXCEPT AS TO MATTERS EXCLUSIVELY CONTROLLED BY THE CONSTITUTION AND STATUTES OF THE UNITED STATES OF AMERICA.** This Agreement is subject to all valid applicable federal, state, and local laws, ordinances, rules, and regulations of duly constituted regulatory authorities having jurisdiction.

12.2 In the event that a regulatory authority having jurisdiction over the Parties orders a change in the terms of this Agreement, the Parties agree to negotiate in good faith a replacement term that will most nearly accomplish the purpose and intent of the original term consistent with the regulatory order. If the Parties cannot reach an agreement over the new term, and if the old term is an essential provision of this Agreement, either Party may elect to terminate this Agreement by providing sixty (60) days prior written notice of such election to the other Party. An election to terminate under this provision shall not affect either Party's duty to perform prior to the effective date of termination.

12.3 In the event any part of this Agreement is declared invalid by a court of competent jurisdiction, the remainder of this Agreement shall remain in full force and effect and shall constitute a binding agreement between the Parties; provided, however, that if either Party determines, in its sole discretion, that there is a material change in this Agreement by reason of any provision or application being finally determined to be invalid, illegal, or unenforceable, that Party may terminate this Agreement upon sixty (60) days prior written notice to the other Party. An election to terminate under this provision shall not affect either Party's duty to perform prior to the effective date of termination.

ARTICLE XIII – FORCE MAJEURE

Neither Party shall be considered in default with respect to any obligation hereunder, other than the payment of money, if prevented from fulfilling such obligations by reason of any cause beyond its reasonable control, including, but not limited to, an act of God, labor disturbance, act of the public enemy, war, insurrection, riot, fire, storm or flood, explosion, breakage or accident to machinery or equipment, a curtailment, order, regulation or restriction imposed by

governmental, military, or lawfully established civilian authorities, or by the making of necessary repairs upon the property or equipment of either Party (“Force Majeure”) and neither Party shall be liable to the other for damages that result from such a Force Majeure event. In the event of the occurrence of an event of Force Majeure, the affected Party shall notify the other Party of such Force Majeure as soon as reasonably possible after the determination that an event of Force Majeure has occurred. If performance by either Party has been prevented by such event, the affected Party shall promptly and diligently attempt to remove the cause of its failure to perform, except that neither Party shall be obligated to agree to any quick settlement of any strike or labor disturbance, that, in the affected Party's opinion, may be inadvisable or detrimental, or to appeal from any administrative or judicial ruling.

ARTICLE XIV - TERMINATION ON DEFAULT

14.1 The term “Default” shall mean the failure of either Party to perform any obligation in the time or manner provided in this Agreement. No Default shall exist where such failure to discharge an obligation (other than the payment of money) is the result of Force Majeure as defined in this Agreement or the result of an act or omission of the other Party. Upon a Default, the non-defaulting Party shall give written notice of such Default to the defaulting Party. Except as provided in Section 14.2, the defaulting Party shall have thirty (30) days from receipt of the Default notice within which to cure such Default; provided however, if such Default is not capable of cure within thirty (30) days, the defaulting Party shall commence such cure within thirty (30) days after Default notice and continuously and diligently complete such cure within ninety (90) days from receipt of the Default notice; and, if cured within such time, the Default specified in such Default notice shall cease to exist.

14.2 If a Default is not cured as provided in this Article, or if a Default is not capable of being cured within the period provided for herein, the non-defaulting Party shall have the right to terminate this Agreement by written notice at any time until cure occurs, and be relieved of any further obligation hereunder and, whether or not that Party terminates this Agreement, to recover from the defaulting Party all amounts due hereunder, plus all other damages and remedies to which it is entitled at law or in equity. The provisions of this Article will survive termination of this Agreement.

14.3 The failure of a Party to this Agreement to insist, on any occasion, upon strict performance of this Agreement will not be considered to waive the obligations, rights, or duties imposed upon the Parties by this Agreement.

ARTICLE XV - MISCELLANEOUS PROVISIONS

15.1 Any undertaking by a Party to the other Party under this Agreement shall not constitute the dedication of the electrical System or any portion thereof of that Party to the public or to the other Party, and it is understood and agreed that any such undertaking shall cease upon the termination of this Agreement.

15.2 IN NO EVENT SHALL EITHER PARTY BE LIABLE UNDER ANY PROVISION OF THIS AGREEMENT FOR ANY LOSSES, DAMAGES, COSTS OR EXPENSES FOR ANY SPECIAL, INDIRECT, INCIDENTAL, CONSEQUENTIAL, OR

PUNITIVE DAMAGES, INCLUDING BUT NOT LIMITED TO LOSS OF PROFIT OR REVENUE, LOSS OF THE USE OF EQUIPMENT, COST OF CAPITAL, COST OF TEMPORARY EQUIPMENT OR SERVICES, WHETHER BASED IN WHOLE OR IN PART IN CONTRACT, IN TORT (INCLUDING NEGLIGENCE), STRICT LIABILITY, OR ANY OTHER THEORY OF LIABILITY. THE LIMITATIONS OF LIABILITY SET FORTH IN THIS SECTION 15.2 ARE NOT INTENDED TO AND SHALL NOT IN ANY MANNER, LIMIT OR QUALIFY THE LIABILITIES AND OBLIGATIONS OF THE PARTIES UNDER ANY OTHER AGREEMENTS BETWEEN THE PARTIES.

15.3 Both Parties to this Agreement represent that there is no agreement or other obligation binding upon it, which, as such Party is presently aware, would limit the effectiveness or frustrate the purpose of this Agreement.

15.4 This Agreement may be amended only upon mutual agreement of the Parties, which amendment will not be effective until reduced in writing and executed by the Parties.

15.5 The descriptive headings of the various sections of this Agreement have been inserted for convenience of reference only and are to be afforded no significance in the interpretation or construction of this Agreement.

15.6 This Agreement will be executed in two or more counterparts, each of which is deemed an original, but all constitute one and the same instrument.

[Signatures are on next page]

IN WITNESS WHEREOF, the Parties have caused this Agreement to be executed by the undersigned authorized representatives.

Electric Transmission Texas, LLC

Sharyland Utilities, L.P.

By:

FFDF1B6D40524A3
<i>Kip M. Fox</i>
DocuSigned By: Kip M. Fox

Name: Kip M. Fox
Title: President

By: *Greg Boggs*_____

Name: Greg Boggs
Title: Senior Vice President *KRF*

Date: 2/28/2019 | 2:53 PM CST

Date: 02/05/2019

EXHIBIT A

FACILITY SCHEDULE NO.	LOCATION OF POINT(S) OF INTERCONNECTION (# of Points)	INTERCONNECTION VOLTAGE (kV)	ORIGINAL EFFECTIVE DATE, PRIOR AMENDMENT DATES OR TERMINATION DATE
1	N. Edinburg to Palmito Tie Line (1)	345	July 28, 2016
2	Riley (4)	345	November 7, 2017
3	Clear Crossing (2)	345	November 7, 2017

FACILITY SCHEDULE NO. 1

1. **Name:** N. Edinburg to Palmito Tie Line
2. **Facility Location:** The Point of Interconnection and change of ownership is located in Cameron County, approximately 0.41 mile north of US 281 on the west side of FM 2556 Road, north of Santa Maria, TX, at SU's 345 kV transmission structure 47/6 (26° 05' 04.09 N., 97° 50' 59.99 W.). More specifically, the Point of Interconnection is where SU's jumpers physically connect to ETT's four-hole pad on ETT's 345 kV transmission line conductors at SU's 345 kV transmission structure (47/6) and where ETT's optical ground wire ("OPGW") is terminated in SU's fiber splice box at structure (47/6).
3. **Delivery Voltage:** 345 kV
4. **Metered Voltage:** N/A
5. **Loss Adjustment Due To Meter Location:** None
6. **Normal Operation of Interconnection:** Closed
7. **One-Line Diagram Attached:** Yes
8. **Facilities Ownership Responsibilities of the Parties:**
 - A. **ETT agrees that it owns the following facilities:**
 - i. One (1) approximately 47.86 circuit miles of 345 kV transmission line from the North Edinburg substation to the Point of Interconnection at SU's 345 kV transmission structure 47/6, and the associated right of way, structures, conductors, insulators, connectors and hardware.
 - ii. The 345 kV dead-end insulator assembly associated with ETT's 345 kV transmission line, including four-hole pads at SU's 345 kV transmission structure 47/6.
 - iii. The OPGW from the North Edinburg substation to SU's fiber splice box at SU's 345 kV transmission structure 47/6.
 - iv. One (1) Palmito substation multiplexer and power supply within SU's Palmito substation
 - B. **SU agrees that it owns the following facilities:**
 - i. One (1) approximately 47.1 circuit miles of 345 kV transmission line from the Palmito substation to the Point of Interconnection at SU's 345 kV transmission structure 47/6, and the associated right of way, structures, conductors, insulators, connectors and hardware.
 - ii. The 345 kV dead-end structure 47/6
 - iii. The conductor jumpers and jumper assemblies at SU's 345 kV transmission structure 47/6.
 - iv. The OPGW from the Palmito substation to SU's fiber splice box at SU's 345 kV transmission structure 47/6

- v. Both Parties' OPGW attachment hardware at five (5) feet intervals at SU's 345 kV transmission structure 47/6.
- vi. The fiber splice box at SU's 345 kV transmission structure 47/6.

9. Facility Operation Responsibilities of the Parties:

Each Party will operate all the facilities it owns.

10. Facility Maintenance Responsibilities of the Parties:

Each Party is responsible for the maintenance of the facilities it owns.

11. Estimated Peak Load: N/A

12. Other Terms and Conditions:

- A. Each Party will attach their OPGW to the top of SU's 345 kV transmission structure 47/6 and route their OPGW down to the splice box.
- B. SU will perform the OPGW splice between the Parties at SU's 345 kV transmission structure 47/6.
- C. ETT will perform the bi-directional, end-to-end testing of the OPGW from the North Edinburg substation to the Palmito substation.
- D. Fiber circuits twenty-five (25) through twenty-eight (28) within the OPGW are reserved for line protection use by both Parties.
- E. ETT shall have exclusive right of use of fiber circuits one (1) through twenty-two (22) within the OPGW from the North Edinburg substation to SU's Palmito substation.
- F. SU shall have exclusive right of use of fiber circuits twenty-three (23), twenty-four (24), and twenty-nine (29) through forty-eight (48) within the OPGW from the North Edinburg substation to SU's Palmito substation.

[The remainder of this page intentionally left blank]

FACILITY SCHEDULE NO. 1 (continued)
One-Line Diagram

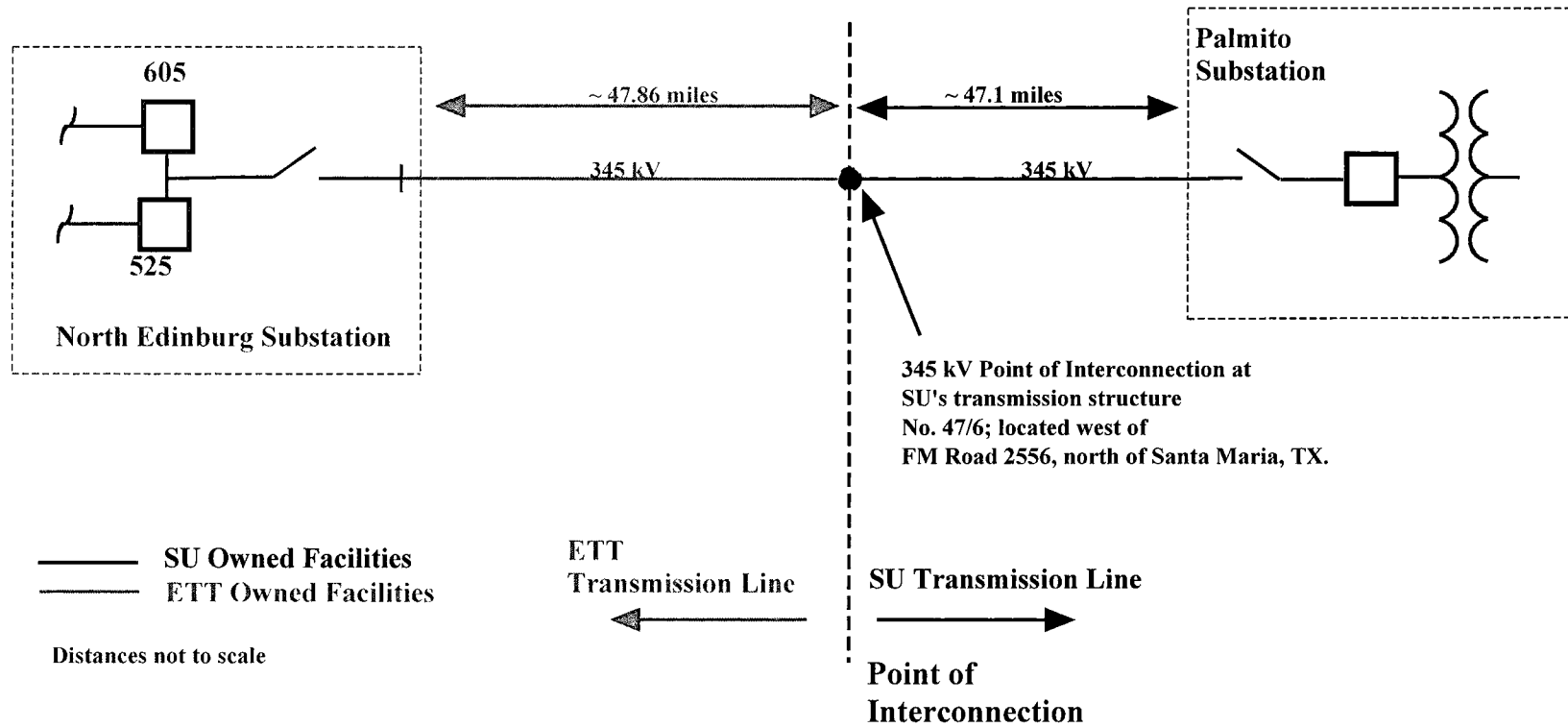

FACILITY SCHEDULE NO. 2

1. **Name:** Riley
2. **Facility Location:** ETT's Riley Switching Station ("Station") is located in Wilbarger County at 12108 FM 2897, Oklaunion, Texas 76373. There are four (4) Points of Interconnection within the Station at i) ETT's outbound dead-end structure ("ETT's Bowman No.1 Dead-end") that terminates the Station to SU's Riley to Bowman No. 1, 345 kV transmission circuit ("Bowman Circuit No.1"); ii) ETT's outbound dead-end structure ("ETT's Bowman No.2 Dead-end") that terminates the Station to SU's Riley to Bowman No.2, 345 kV transmission circuit ("Bowman Circuit No.2"); iii) ETT's outbound dead-end structure ("ETT's Krum West No.1 Dead-end") that terminates the Station to SU's Riley to Krum West No.1, 345 kV transmission circuit ("Krum West Circuit No.1"); and iv) ETT's outbound dead-end structure ("ETT's Krum West No.2 Dead-end") that terminates the Station to SU's Riley to Krum West No.2, 345 kV transmission circuit ("Krum West Circuit No.2") (the dead-end structures collectively, "ETT's Dead-end Structures") (the transmission lines collectively, "SU's Transmission Lines"). More specifically the Points of Interconnection are where the terminal lugs on the ends of ETT's jumpers originating from the Station's 345 kV bus physically connect to SU's Transmission Lines at SU's compression dead-end terminal lugs on the line-side of ETT's Dead-end Structures.
3. **Delivery Voltage:** 345 kV
4. **Metered Voltage:** 345 kV
5. **Loss Adjustment Due To Meter Location:** None
6. **Normal Operation of Interconnection:** Closed
7. **One Line Diagram Attached:** Yes
8. **Facilities Ownership Responsibilities of the Parties:**
 - A. **SU agrees that it owns the following facilities:**
 - i. that portion of the Riley to Bowman 345 kV transmission line consisting of two (2) 345 kV transmission circuits (Bowman Circuit No.1 and Bowman Circuit No.2) from the Station to structure (13/2) along the Riley to Bowman 345 kV transmission line, including associated structures, conductors, insulators, connectors, hardware
 - ii. one (1) 7/16 inch steel shield wire on Bowman Circuit No.2 from structure (13/2) to ETT's Bowman No.2 Dead-end
 - iii. one (1) optical ground wire ("OPGW") on Bowman Circuit No.1 from structure (13/2) to SU's dead-end structure (1/2) located approximately 750 feet outside the Station fence
 - iv. one (1) 7/16 inch steel shield wire from SU's dead-end structure (1/2) to ETT's Bowman No.1 Dead-end

- v. that portion of the Riley to Krum West 345 kV transmission line consisting of two (2) 345 kV transmission circuits (Krum West Circuit No.1 and Krum West Circuit No.2) from the Station to structure (14/1) along the Riley to Krum West transmission line, including associated structures, conductors, insulators, connectors, and hardware
- vi. one (1) 7/16 inch steel shield wire on Krum West Circuit No.1 from structure (14/1) to ETT's Krum West No.1 Dead-end
- vii. one (1) OPGW on Krum West Circuit No.2 from structure (14/1) to SU's dead-end structure (1/1) located approximately 680 feet outside the Station fence
- viii. one (1) 7/16 inch steel shield wire from SU's dead-end structure (1/1) to ETT's Krum West No.2 Dead-end

B. ETT agrees that it owns the following facilities:

- i. the Station and all the facilities within it, except for those facilities in the Station identified as being furnished and owned by SU in Section 8 above
- ii. ETT's Dead-end Structures
- iii. 345 kV bus jumpers connecting to SU's Transmission Lines at ETT's Dead-end Structures, including associated connectors
- iv. Hand holes as required for pulling and coil storage of fiber cables

9. Facility Operation Responsibilities of the Parties:

Each Party will operate all the facilities it owns.

10. Facility Maintenance Responsibilities of the Parties:

Each Party is responsible for the maintenance of the facilities it owns.

11. Estimated Peak Load: N/A

12. Supplemental Terms and Conditions:

12.1 The Parties agree to the following conditions:

- a) no fiber optic cable with metallic members shall be extended into the Station control house (fiber optic cable with metallic members includes, but is not limited to, optical ground wire ("OPGW"), fiber optic cable with an integral trace wire, and metallic-armored fiber optic cable)
- b) fiber optic entrance cable systems shall each include all-dielectric fiber optic entrance cable, the necessary outdoor splice boxes, trays and fusion splice sleeves and the necessary indoor splice housing, trays, fusion splice sleeves, fiber pigtails and fiber distribution panel ("FDP")
- c) each Party shall, at its sole expense, perform splicing of all fibers it owns, including the fibers in transition splices and port terminations in FDPs associated with OPGW and OPGW jumpers
- d) SU shall perform the splicing at the interface point between SU's fiber cables and ETT's fiber cables.

- 12.2 Each Party shall provide station operational data for facilities it owns or controls to ERCOT via Inter-control Center Communications Protocol (ICCP), or other methods acceptable to ERCOT.
- 12.3 Any grounding connections between the Station and SU's telecommunications facilities shall meet ETT's specifications.
- 12.4 Each Party has adopted formal switching procedures that govern safety related issues concerning the operation of its switches connected to these Points of Interconnection and has provided a copy of these procedures to the other Party. Each Party agrees to comply with the aforementioned switching procedures of the other Party applicable to the Points of Interconnection and will notify the other Party in writing of any changes to its procedures relating to the Points of Interconnection.

[The remainder of this page is intentionally left blank]

FACILITY SCHEDULE NO. 2 (continued) One Line Diagram

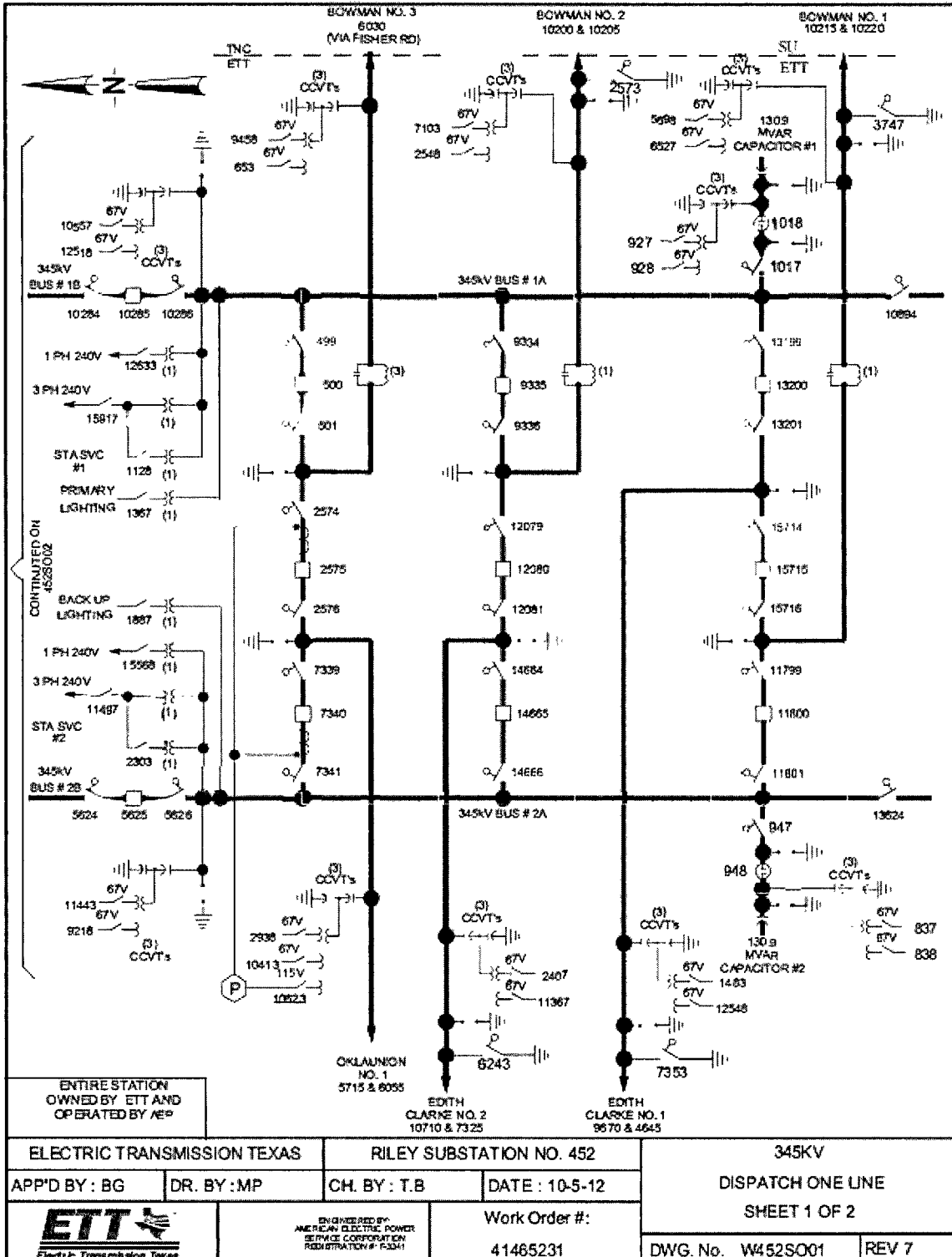

FACILITY SCHEDULE NO. 2 (continued) One Line Diagram

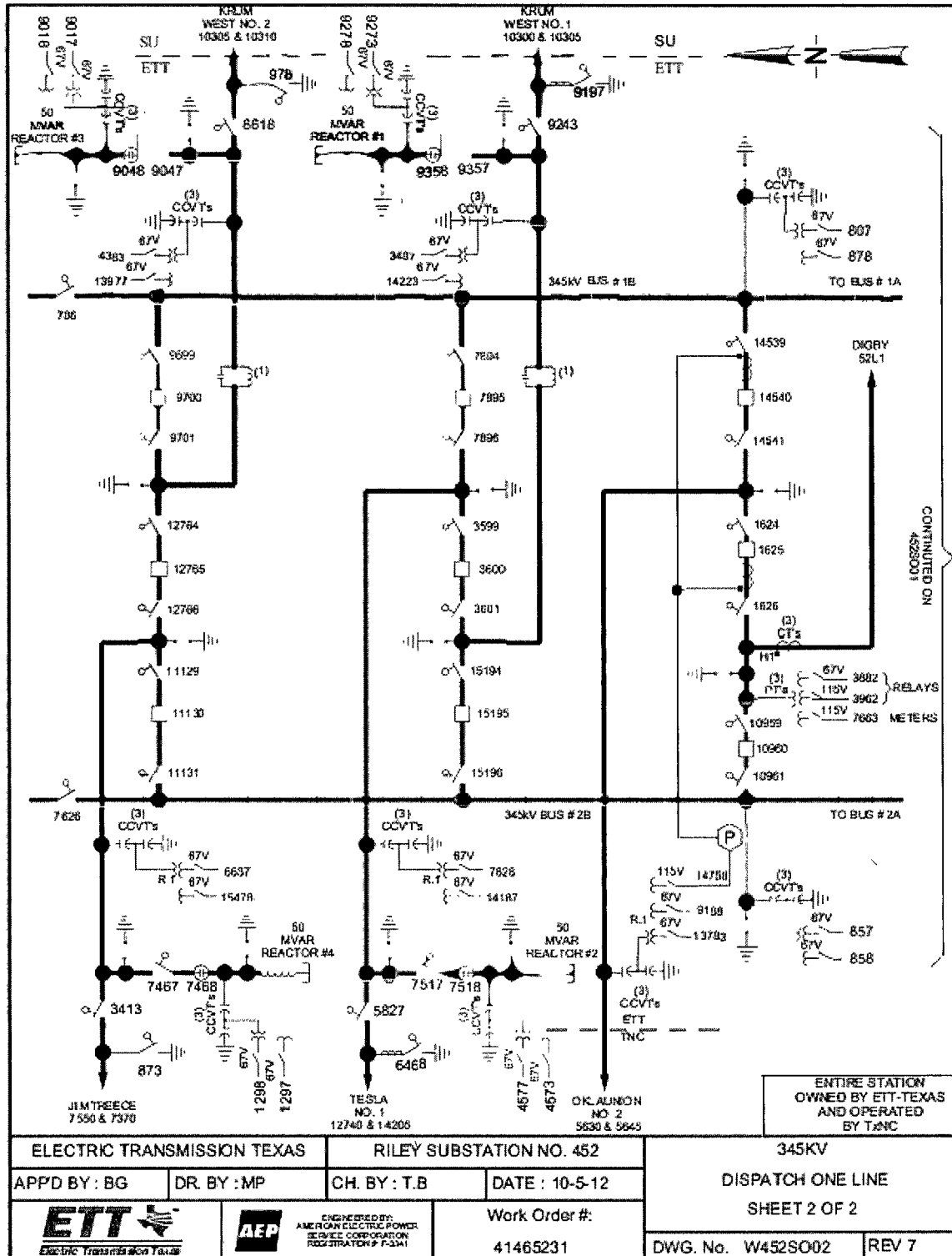

FACILITY SCHEDULE NO. 2 (continued) One Line Diagram

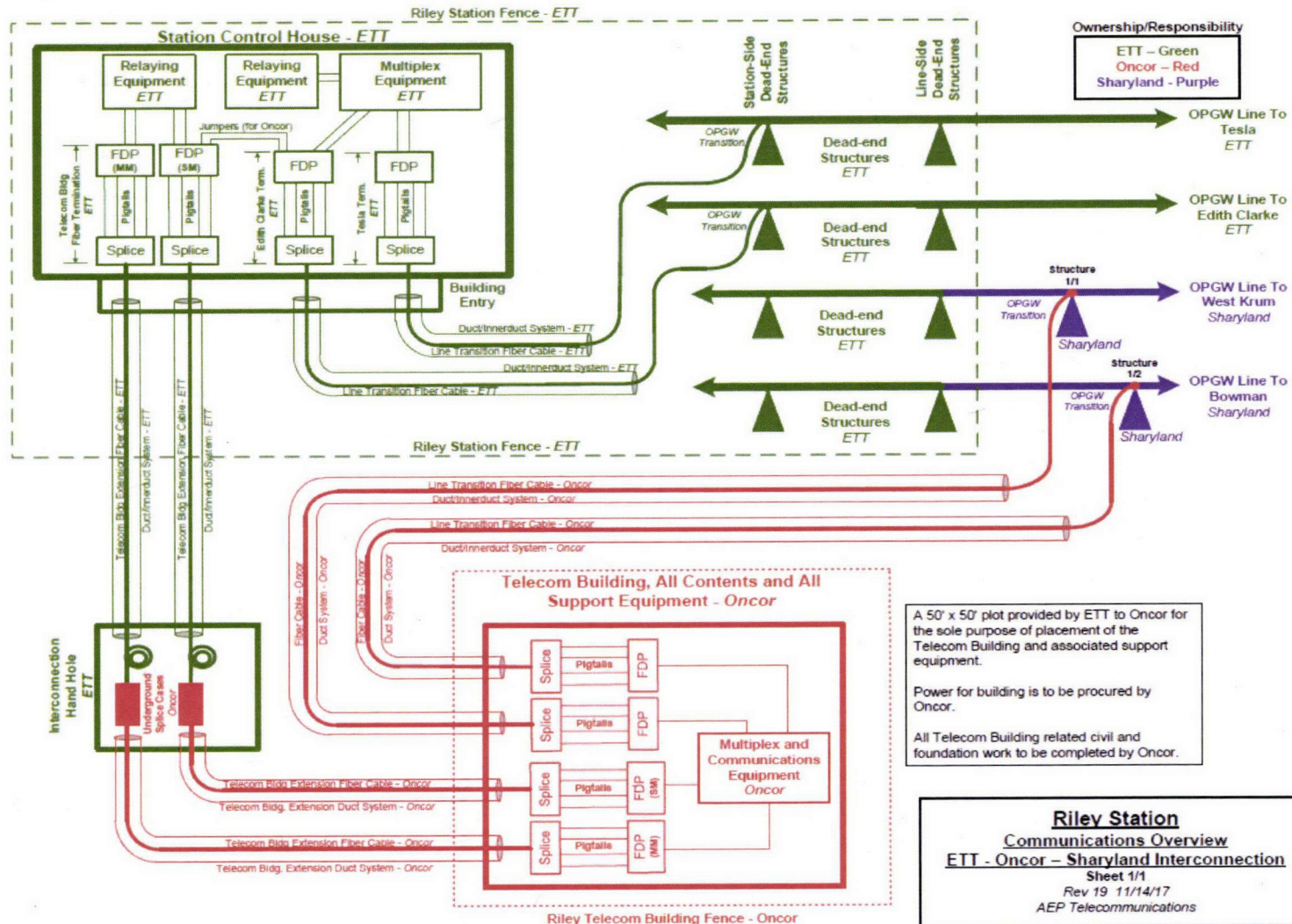

FACILITY SCHEDULE NO. 3

1. **Name:** Clear Crossing
2. **Facility Location:** ETT's Clear Crossing Switching Station ("Station") is located in Haskell County at 11780 Loop Road, Haskell, Texas 79521, (33° 00' 06" N., 99° 36' 24" W.). There are two (2) Points of Interconnection within the Station at i) ETT's north 345 kV dead-end structure that terminates the Station to SU's Clear Crossing to Willow Creek north 345 kV transmission circuit ("Willow Creek Circuit No.1") and ii) ETT's south 345 kV dead-end structure that terminates the Station to SU's Clear Crossing to Willow Creek south 345 kV transmission circuit ("Willow Creek Circuit No.2"), (ETT's north and south 345 kV dead-end structures collectively, "ETT's Dead-end Structures"), (Willow Creek Circuit No.1 and Willow Creek Circuit No.2 collectively, "SU's Transmission Circuits"). More specifically the Points of Interconnection are where the terminal lugs on the end of ETT's jumpers originating from the Station's 345 kV bus physically connect to SU's Transmission Circuits at SU's compression dead-end terminal lugs on the line-side of ETT's Dead-end Structures.
3. **Delivery Voltage:** 345 kV
4. **Metered Voltage:** 345 kV
5. **Loss Adjustment Due To Meter Location:** None
6. **Normal Operation of Interconnection:** Yes
7. **One Line Diagram Attached:** Yes
8. **Facilities Ownership Responsibilities of the Parties:**
 - A. **SU agrees that it owns the following facilities:**
 - i. that portion of the Clear Crossing to Willow Creek 345 kV transmission line consisting of SU's Transmission Circuits from the Station to structure (61/6) along the Clear Crossing to Willow Creek transmission line, including associated structures, conductors, insulators, connectors, hardware
 - ii. one (1) 7/16 inch steel shield wire on Willow Creek Circuit No.1
 - iii. one (1) optical ground wire ("OPGW") on Willow Creek No.2 from structure (61/6) to SU's south 345 kV dead-end structure (1/1B) located approximately 300 feet outside the Station fence
 - iv. one (1) 7/16 inch steel shield wire from SU's south 345 kV dead-end structure (1/1B) to ETT's south 345 kV dead-end structure
 - B. **ETT agrees that it owns the following facilities:**
 - i. the Station and all the facilities within it, except SU's Transmission Circuits which extend into the Station
 - ii. ETT's Dead-end Structures
 - iii. the 345 kV jumpers connecting to SU's Transmission Circuits at ETT's Dead-end Structures, including associated connectors
 - iv. Hand holes as required for pulling and coil storage of fiber cables

9. Facility Operation Responsibilities of the Parties:

Each Party will operate all the facilities it owns

10. Facility Maintenance Responsibilities of the Parties:

Each Party is responsible for the maintenance of the facilities it owns.

11. Estimated Peak Load: N/A

12. Supplemental Terms and Conditions:

12.1 The Parties agree to the following conditions:

- a) no fiber optic cable with metallic members shall be extended into the Station control house (fiber optic cable with metallic members includes, but is not limited to, optical ground wire (“OPGW”), fiber optic cable with an integral trace wire, and metallic-armored fiber optic cable)
- b) fiber optic entrance cable systems shall each include all-dielectric fiber optic entrance cable, the necessary outdoor splice boxes, trays and fusion splice sleeves and the necessary indoor splice housing, trays, fusion splice sleeves, fiber pigtailed and fiber distribution panels (“FDPs”)
- c) each Party shall, at its sole expense, perform splicing of all fibers it owns, including the fibers in transition splices and port terminations in FDPs associated with OPGW and OPGW jumpers
- d) SU shall perform the splicing at the interface point between SU’s fiber cables and ETT’s fiber cables.

12.2 Each Party shall provide station operational data for facilities it owns or controls to ERCOT via Inter-control Center Communications Protocol (ICCP), or other methods acceptable to ERCOT.

12.3 Any grounding connections between the Station and SU’s telecommunications facilities shall meet ETT’s specifications.

12.4 ETT shall grant land rights to SU for (i) SU’s Transmission Circuits and associated facilities; (ii) SU’s telecommunications facilities; and (iii) access rights related to such facilities.

12.5 Each Party has adopted formal switching procedures that govern safety related issues concerning the operation of its switches connected to these Points of Interconnection and has provided a copy of these procedures to the other Party. Each Party agrees to comply with the aforementioned switching procedures of the other Party applicable to the Points of Interconnection and will notify the other Party in writing of any changes to its procedures relating to the Points of Interconnection.

FACILITY SCHEDULE NO. 3 (continued) One Line Diagram

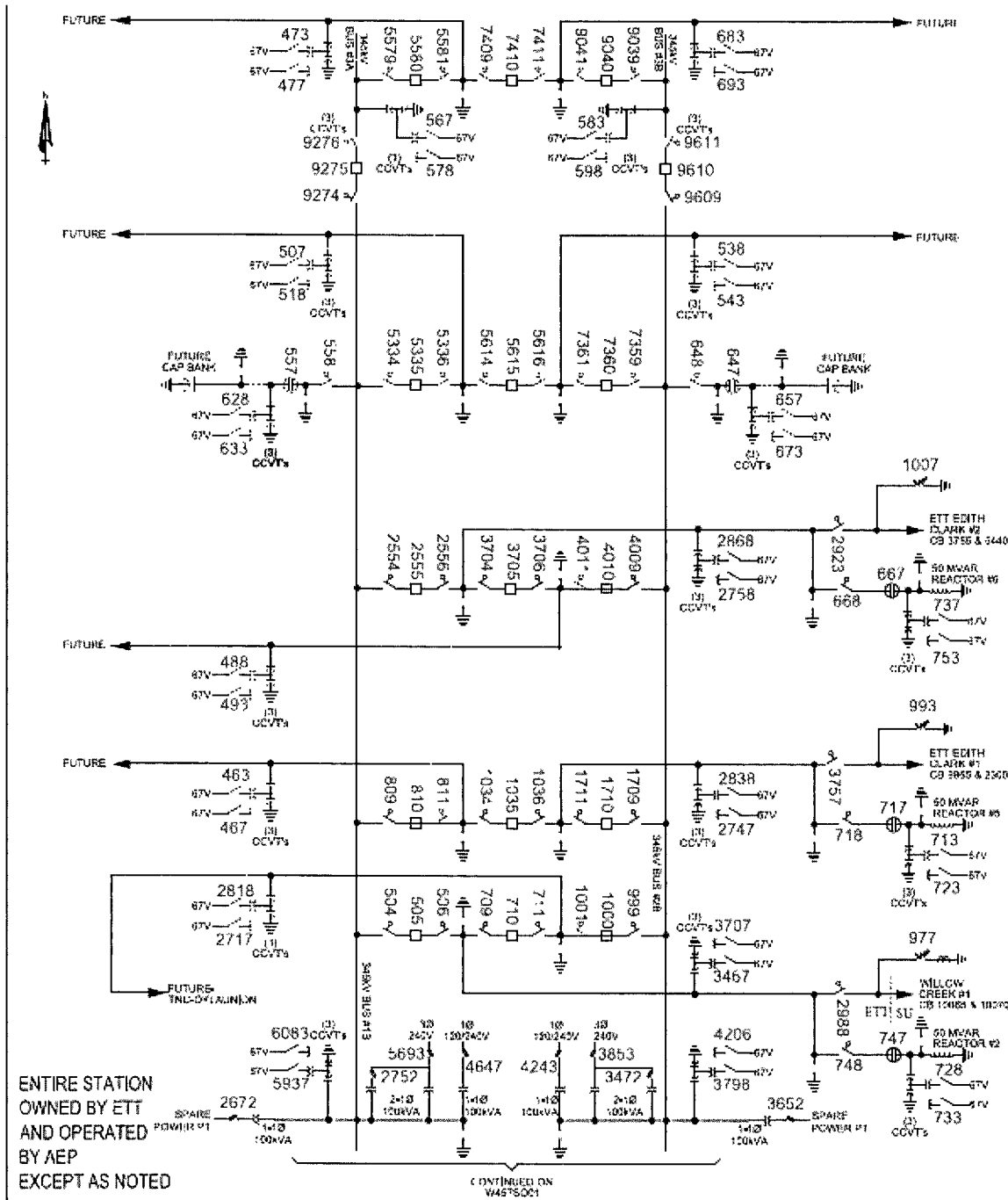

ENTIRE STATION
OWNED BY ETT
AND OPERATED
BY AEP
EXCEPT AS NOTED

CONTINUED ON
W457S001

ELECTRIC TRANSMISSION TEXAS		CLEAR CROSSING STATION		345KV	
APP'D BY : RJW	DR. BY : DJM	CH. BY : DJM	DATE : 10/19/13	ONE LINE DIAGRAM	
		DIVISION: AMERICAN ELECTRIC POWER SERVICE CORPORATION 8201 STRATTON WY #3341		SHEET 2 OF 2	
				Work Order #: 41575550	

FACILITY SCHEDULE NO. 3 (continued) One Line Diagram

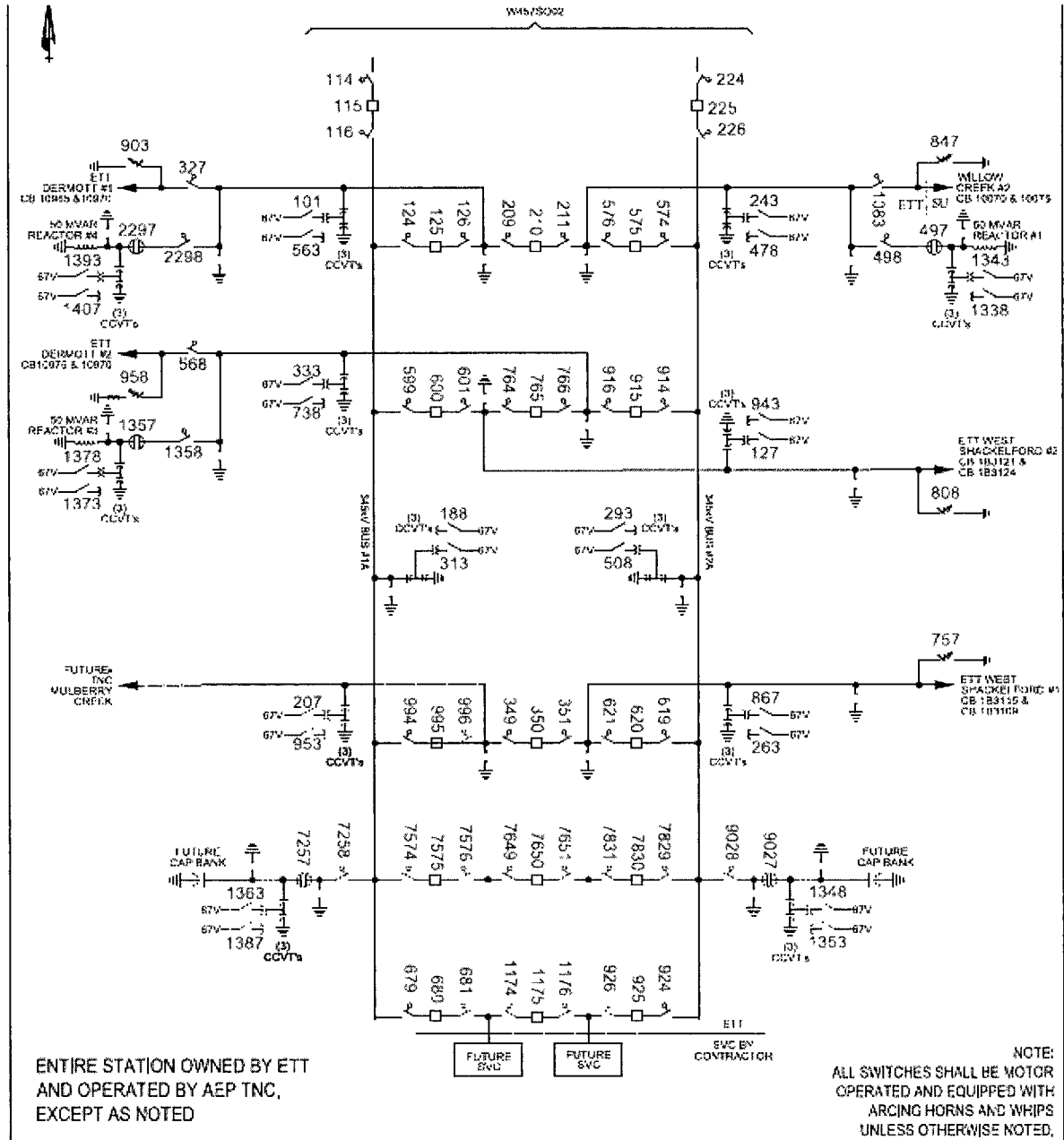

ELECTRIC TRANSMISSION TEXAS		CLEAR CROSSING STATION		345kV	
APP'D BY : RJW	DR. BY : DJM	CH. BY : DJM	DATE : 10/19/13	ONE LINE DIAGRAM	
		ENGINEERED BY AMERICAN ELECTRIC POWER BRIDGE CORPORATION REGISTRATION # 104447 3344		SHEET 1 OF 2	
				Work Order #: 41575550	

FACILITY SCHEDULE NO. 3 (continued) One Line Diagram

