



Control Number: 35077



Item Number: 233

Addendum StartPage: 0

11/17/23 Fri 3:02
FILING CLERK

Project No. 35077

**ERCOT STANDARD GENERATION
INTERCONNECTION AGREEMENT**

Between

LCRA Transmission Services Corporation

and

RRE Austin Solar, LLC

May 16, 2011

333

**ERCOT STANDARD GENERATION
INTERCONNECTION AGREEMENT**

Between

LCRA TRANSMISSION SERVICES CORPORATION

and

RRE AUSTIN SOLAR, LLC

May 16, 2011

A handwritten signature or mark, possibly initials, located in the lower-left quadrant of the page.

TABLE OF CONTENTS

| | |
|--|-----------|
| ERCOT STANDARD GENERATION INTERCONNECTION AGREEMENT | 1 |
| Exhibit "A" Terms and Conditions of the ERCOT Standard Generation Interconnection Agreement | 3 |
| ARTICLE 1. DEFINITIONS | 3 |
| ARTICLE 2. TERMINATION | 5 |
| ARTICLE 3. REGULATORY FILINGS | 6 |
| ARTICLE 4. INTERCONNECTION FACILITIES ENGINEERING, PROCUREMENT, AND CONSTRUCTION | 6 |
| ARTICLE 5. FACILITIES AND EQUIPMENT | 11 |
| ARTICLE 6. OPERATION AND MAINTENANCE | 15 |
| ARTICLE 7. DATA REQUIREMENTS | 17 |
| ARTICLE 8. PERFORMANCE OBLIGATION | 19 |
| ARTICLE 9. INSURANCE | 20 |
| ARTICLE 10. MISCELLANEOUS | 22 |
| Exhibit "B" Time Schedule | 31 |
| Exhibit "C" Interconnection Details | 32 |
| Exhibit "D" Notice and EFT Information of the ERCOT Standard Generation Interconnection Agreement | 43 |
| Exhibit "E" Security Arrangement Details | 44 |

ERCOT STANDARD GENERATION INTERCONNECTION AGREEMENT

This Standard Generation Interconnection Agreement is made and entered into this 16th day of May, 2011, between LCRA Transmission Services Corporation, a Texas non-profit corporation ("Transmission Service Provider") and RRE Austin Solar, LLC, a Texas limited liability company ("Generator"), hereinafter individually referred to as "Party," and collectively referred to as "Parties." In consideration of the mutual covenants and agreements herein contained, the Parties hereto agree as follows:

Transmission Service Provider represents that it is a public utility that owns and operates facilities for the transmission and distribution of electricity. Generator represents that it will own and operate the Plant. Pursuant to the terms and conditions of this Agreement, Transmission Service Provider shall interconnect Generator's Plant with Transmission Service Provider's System consistent with the results of the Facilities Study Agreement executed between the Parties on 08/02/2010.

This Agreement applies only to the Plant and the Parties' interconnection facilities as identified in Exhibit "C."

This Agreement shall become effective on May 16, 2011, subject to Governmental Authority approval, if required, and shall continue in full force and effect until terminated in accordance with Exhibit "A."

This Agreement will be subject to the following, all of which are incorporated herein:

- A. The "Terms and Conditions of the ERCOT Standard Generation Interconnection Agreement" attached hereto as Exhibit "A";
- B. The ERCOT Requirements (unless expressly stated herein, where the ERCOT Requirements are in conflict with this Agreement, the ERCOT Requirements shall prevail);
- C. The PUCT Rules (where the PUCT Rules are in conflict with this Agreement, the PUCT Rules shall prevail);
- D. The Time Schedule attached hereto as Exhibit "B";
- E. The Interconnection Details attached hereto as Exhibit "C";
- F. The notice requirements attached hereto as Exhibit "D"; and
- G. The Security Arrangement Details attached hereto as Exhibit "E."

- Remainder of Page Intentionally Left Blank -

IN WITNESS WHEREOF, the Parties have executed this Agreement in duplicate originals, each of which shall constitute and be an original effective Agreement between the Parties.

RRE Austin Solar, LLC

By: Daven Mehta

Signature: *Daven Mehta*

Title: Chief Executive Officer

Date: 05/16/2011

LCRA Transmission Services Corporation

By: Ray Pfefferkorn, P.E.

Signature: *Ray Pfefferkorn*

Title: Transmission Engineering Manager

Date: 5/20/11



Exhibit "A"
**Terms and Conditions of the ERCOT
Standard Generation Interconnection Agreement**

ARTICLE 1. DEFINITIONS

Capitalized terms shall have the meanings as set forth below, except as otherwise specified in the Agreement:

- 1.1 "CCN" shall mean a Certificate of Convenience and Necessity issued by the PUCT.
- 1.2 "Commercial Operation" shall mean the date on which Generator declares that the construction of the Plant has been substantially completed, Trial Operation of the Plant has been completed, and the Plant is ready for dispatch.
- 1.3 "Control Area" shall have the meaning ascribed thereto in PUCT Rule 25.5(19) or its successor.
- 1.4 "ERCOT" shall mean the Electric Reliability Council of Texas, Inc.
- 1.5 "ERCOT Requirements" means the ERCOT Operating Guides, ISO Generation Interconnection Procedures as well as any other documents adopted by the ISO or ERCOT relating to the interconnection and operation of generators and transmission systems in ERCOT as amended from time to time, and any successors thereto. Any requirement in the foregoing documents imposed upon generation entities or generation facilities shall become the responsibility of the Generator, and any requirements imposed on transmission providers or transmission facilities shall become the responsibility of the TSP.
- 1.6 "Facilities Study" shall have the meaning as described in PUCT Rule 25.198(d) or its successor.

- 1.7 “Facilities Study Agreement” shall mean an agreement executed by the Parties relating to the performance of the Facilities Study.
- 1.8 “GIF” shall mean Generator’s interconnection facilities as described in Exhibit “C.”
- 1.9 “Good Utility Practice” shall have the meaning described in PUCT Rule 25.5(56) or its successor.
- 1.10 “Governmental Authority(ies)” shall mean any federal, state, local or municipal body having jurisdiction over a Party.
- 1.11 “In-Service Date” shall be the date, as reflected in Exhibit “B,” that the TIF will be ready to connect to the GIF.
- 1.12 “ISO” shall mean the ERCOT Independent System Operator.
- 1.13 “Plant” shall mean the electric generation facility owned and operated by the Generator, as specified in Exhibit “C.”
- 1.14 “Point of Interconnection” shall mean the location(s) where the GIF connects to the TIF as negotiated and defined by the Parties and as shown on Exhibit “C” of this Agreement.
- 1.15 “PUCT” shall mean the Public Utility Commission of Texas.
- 1.16 “PUCT Rules” shall mean the Substantive Rules of the PUCT.
- 1.17 “Reasonable Efforts” shall mean the use of Good Utility Practice and the exercise of due diligence.
- 1.18 “System Protection Equipment” shall mean those facilities located within the TIF and the GIF as described in Section 5.6 and Exhibit “C.”
- 1.19 “System Security Study” shall have the meaning as described in PUCT Rule 25.198c or its successor.

1.20 “TCOS” shall mean the TSP’s transmission cost of service as allowed by the applicable Governmental Authority.

1.21 “TIF” shall mean the TSP’s interconnection facilities as described in Exhibit “C” to this Agreement.

1.22 “Trial Operation” shall mean the process by which the Generator is engaged in on-site test operations and commissioning of the Plant prior to Commercial Operation.

1.23 “TSP” shall mean the Transmission Service Provider.

1.24 “TSP System” shall mean the electric transmission facilities, including the TIF, and all associated equipment and facilities owned and/or operated by the TSP.

ARTICLE 2. TERMINATION

2.1 Termination Procedures. This Agreement may be terminated as follows:

A. the Generator may terminate this Agreement after giving the TSP thirty (30) days advance written notice; or

B. the TSP may terminate this Agreement (subject to Governmental Authority approval, if required) on written notice to the Generator if the Generator’s Plant has not achieved Commercial Operation within one year after the scheduled Commercial Operation date reflected in Exhibit “B”; or

C. either Party may terminate this Agreement in accordance with Section 10.6.

2.2 Termination Costs. If a Party elects to terminate the Agreement pursuant to Section 2.1 above, the Generator shall pay all costs incurred (or committed to be incurred) by TSP, as of the date of the other Party’s receipt of such notice of termination, that are the responsibility of the Generator under this Agreement. In the event of termination by either Party, both Parties shall use commercially reasonable efforts to mitigate the damages and charges that they may incur as

a consequence of termination. The provisions of the Sections 2.2 and 2.3 shall survive termination of the Agreement.

2.3 Disconnection. Upon termination of this Agreement, the Parties will disconnect the GIF from the TIF.

ARTICLE 3. REGULATORY FILINGS

3.1 Filing. The TSP shall file this executed Agreement with the appropriate Governmental Authority, if required. Any portions of this Agreement asserted by Generator to contain competitively sensitive commercial or financial information shall be filed by the TSP identified as “confidential” under seal stating, for the TSP’s showing of good cause, that Generator asserts such information is confidential information and has requested such filing under seal. If requested by the TSP, Generator shall provide the TSP, in writing, with the Generator’s basis for asserting that the information referred to in this Section 3.1 is competitively sensitive information, and the TSP may disclose such writing to the appropriate Governmental Authority.

3.2 Regulatory Approvals. Unless exempt, the TSP shall timely request ISO and all regulatory approvals necessary for it to carry out its responsibilities under this Agreement. Such approvals shall include any CCN required for the construction of the TIF.

ARTICLE 4. INTERCONNECTION FACILITIES ENGINEERING, PROCUREMENT, AND CONSTRUCTION

4.1 Options. The Generator shall select one of the following options (subsection A or subsection B) and include the selected option in Exhibit “B” for completion of the TIF:

A. The TSP shall design, procure, and construct the TIF, using Reasonable Efforts to complete the TIF by the In-Service Date reflected in Exhibit “B.” The TSP will utilize its own resources and will contract for additional resources, as reasonably necessary, to meet the In-Service Date. Such resources shall include, as the TSP believes is reasonable, use of other

contractors, other equipment suppliers, other material suppliers, additional contract personnel, additional payments to contractors for expedited work, and premiums paid to equipment and material suppliers for expedited delivery. The TSP shall not be required to undertake any initiative which is inconsistent with its standard safety practices, its material and equipment specifications, its design criteria and construction procedures, its labor agreements, applicable laws and regulations, and ERCOT Requirements. In the event the TSP reasonably expects that it will not be able to complete the TIF by the In-Service Date, the TSP will promptly provide written notice to the Generator and will undertake Reasonable Efforts to meet the earliest date thereafter.

B. (i) The TSP shall design, procure, and construct the TIF by the In-Service Date reflected in Exhibit "B." The Parties acknowledge that the In-Service Date was either agreed upon through good faith negotiations or designated by the Generator upon failure of the Parties to agree. In the process of negotiating the In-Service Date, Generator will request a date upon which it reasonably expects it will be ready to begin use of the TIF and upon which it reasonably expects to begin doing so. Any date designated by the Generator shall in no event be less than fifteen months from the date that all conditions of Sections 4.2 and 4.3 have been satisfied. The designated In-Service Date will be extended day for day for each day that the ISO refuses to grant clearances to install equipment. If the TSP fails to complete the TIF by the In-Service Date reflected in Exhibit "B," the TSP shall pay the Generator liquidated damages in accordance with this Section 4.1.B.

(ii) The Parties agree that actual damages to the Generator, in the event the TIF are not completed by the In-Service Date, may include Generator's fixed operation and maintenance costs and lost opportunity costs. Such actual damages are uncertain and

impossible to determine at this time. The Parties agree that, because of such uncertainty, any liquidated damages paid by the TSP to the Generator shall be an amount equal to ½ of 1% of the actual cost of the TIF, per day. However, in no event shall the total liquidated damages exceed 20% of the actual cost of the TIF. The Parties agree that such liquidated damages are less than the Generator's actual damages. The Parties agree that the foregoing payments will be made by the TSP to the Generator as just compensation for the damages caused to the Generator, which actual damages are uncertain and impossible to determine at this time, and as reasonable liquidated damages, but not as a penalty or a method to secure performance of this Agreement.

(iii) The TSP shall apply to have the full costs of the TIF included in TCOS. If the PUCT issues a final, appealable order excluding from TCOS any portion of the TIF costs, including higher contractor and vendor costs due to liquidated damage provisions in those contracts and insurance costs to cover liquidated damages, which costs may have been reasonably incurred but which the PUCT finds should not be recovered through TCOS, the Generator shall reimburse the TSP for such costs in an amount not to exceed the difference between the TSP's estimate of the cost of the TIF under section 4.1.A and the TSP's estimate of the cost of the TIF under Section 4.1.B as reflected in Exhibit "C." Such costs shall be estimated using Good Utility Practice.

(iv) No liquidated damages shall be paid to Generator if the Generator is not ready to commence use of the TIF for the delivery of power to the Plant for Trial Operation or export of power from the Plant on the In-Service Date, unless the Generator would have been able to commence use of the TIF for the delivery of power to the Plant for Trial Operation or export of power from the Plant but for TSP's delay.

(v) If the In-Service Date has been designated by the Generator upon a failure of the Parties to agree on the In-Service Date, the TSP may, at its option, require the Generator to subcontract with the TSP for all or part of the design, procurement and construction of the TIF in accordance with the TSP's standard subcontractor agreements. In such event, the TSP shall be subject to the payment of liquidated damages to the Generator only if the In-Service Date is not met solely due to the TSP's failure to complete the portion of the TIF for which the TSP has retained responsibility. It is the intent of this subsection to give the TSP full control of the contents and quality of the TIF. To the extent the Generator acts as a subcontractor to the TSP, the following will apply: 1) The Generator shall engineer, procure equipment, and construct the TIF (or portions thereof) using Good Utility Practice and using standards and specifications provided in advance by the TSP; 2) In its engineering, procurement and construction of the TIF, the Generator shall comply with all requirements of law to which the TSP would be subject in the engineering, procurement or construction of the TIF; 3) The TSP shall review and approve the engineering design, acceptance tests of equipment, and the construction of the TIF; 4) The TSP shall have the right to approve and accept for operation the TIF in accordance with the standards and specifications provided in advance by the TSP, such approval and acceptance shall not be unreasonably withheld, conditioned, or delayed; 5) Should any phase of the engineering, equipment procurement, or construction of the TIF, including selection of subcontractors, not meet the standards and specifications provided by the TSP, and therefore be deemed unacceptable, then the Generator shall be obligated to remedy that portion of the TIF or selection of subcontractors that is deemed unacceptable, the TSP's approval of the Generator's selection of subcontractors will not be unreasonably withheld, conditioned or delayed; and 6) Once the TIF is accepted for operation by the TSP, then the TSP shall reimburse the Generator

for the reasonable and necessary costs incurred by the Generator to complete the TIF, not to exceed the amount specified in the subcontract. Such reimbursement shall be made within thirty days after receipt of the invoice, unless otherwise agreed to by the Parties.

4.2 Equipment Procurement. If responsibility for construction of the TIF is borne by the TSP, then the TSP shall commence design of the TIF and procure necessary equipment within a reasonable time after all of the following conditions are satisfied:

A. The TSP has completed the Facilities Study pursuant to the Facilities Study Agreement;

B. The TSP has received written authorization to proceed with design and procurement from the Generator by the date specified in Exhibit "B"; and

C. The Generator has provided security to the TSP in accordance with Section 8.3 by the dates specified in Exhibit "B."

4.3 Construction Commencement. The TSP shall commence construction of the TIF as soon as practicable after the following additional conditions are satisfied:

A. Approval of the appropriate Governmental Authority has been obtained for any facilities requiring regulatory approval;

B. Necessary real property rights, if any, have been obtained;

C. The TSP has received written authorization to proceed with construction from the Generator by the date specified in Exhibit "B"; and

D. The Generator has provided security to the TSP in accordance with Section 8.3 by the dates specified in Exhibit "B."

4.4 Work Progress. The Parties will keep each other advised periodically as to the progress of their respective design, procurement and construction efforts. If, at any time, the Generator

becomes aware that the completion of the TIF will not be required until after the specified In-Service Date, the Generator will promptly provide written notice to the TSP of a new, later In-Service Date.

4.5 Conditions Precedent Delay. To the extent this Agreement incorporates a specified In-Service Date and the Generator fails to satisfy conditions precedent under Sections 4.2 and 4.3 so that the TSP may meet the In-Service Date, the Parties will negotiate in good faith to establish a new schedule for completion of the TIF.

ARTICLE 5. FACILITIES AND EQUIPMENT

5.1 Information Exchange. The Parties shall exchange information and mutually agree upon the design and compatibility of the Parties' interconnection facilities. The Parties shall work diligently and in good faith to make any necessary design changes to ensure compatibility of the GIF to the TSP System.

5.2 GIF Construction. Generator agrees to cause the GIF to be designed and constructed in accordance with Good Utility Practice, ERCOT Requirements and the National Electrical Safety Code in effect at the time of construction. Within one-hundred and twenty (120) days after Commercial Operation, unless the Parties agree on another mutually acceptable deadline, the Generator shall deliver to the TSP the following "as-built" drawings, information and documents for the GIF: a one-line diagram, a site plan showing the Plant and the GIF, plan and elevation drawings showing the layout of the GIF, a relay functional diagram, relaying AC and DC schematic wiring diagrams and relay settings for all facilities associated with the Generator's main-power transformers, the facilities connecting the Generator to the main power transformers and the GIF, and the impedances (determined by factory tests) for the associated main power transformers and the generators.

5.3 TIF Construction. The TSP agrees to cause the TIF to be designed and constructed in accordance with Good Utility Practice, ERCOT Requirements and the National Electrical Safety Code in effect at the time of construction.

5.4 Equipment Changes. For facilities not described in Exhibit "C," if either Party makes equipment changes to the Plant, the GIF, the TIF or the TSP System which it knows will affect the operation or performance of the other Party's interconnection facilities, the Parties agree to notify the other Party, in writing, of such changes. Such changes shall be made in accordance with ERCOT Requirements and coordinated between the Parties.

5.5 Metering, Telemetry and Communications Requirements.

A. Metering and telemetry of data will be accomplished in accordance with ERCOT Requirements. The specific metering, telemetry and communications equipment to be installed and data to be telemetered are described in Exhibit "C."

B. At the Point of Interconnection, the metering and telemetry equipment shall be owned by the TSP. However, the TSP shall provide the Generator with metering and telemetry values in accordance with ERCOT Requirements.

C. A minimum set of inputs to the telemetry equipment are specified in Exhibit "C." Additional sets of inputs may be subsequently mutually agreed upon.

D. The TSP will notify the Generator at least five (5) working days in advance of any planned maintenance, inspection, testing, or calibration of the metering equipment, unless otherwise agreed to in writing. The Generator, or its designated representative, shall have the right to be present for these activities and to receive copies of any documents related to the procedures and results.

E. Prior to the connection of the GIF to the TIF, acceptance tests will be performed by the owning Party to ensure the proper functioning of all metering, telemetry and communications equipment associated with the Point of Interconnection and both Parties' interconnection facilities, and to verify the accuracy of data being received by the TSP, the Control Area(s) in which the Plant and the TSP are located and the Generator. All acceptance tests will be performed consistent with ERCOT Requirements.

F. The TSP shall, in accordance with Good Utility Practice and ERCOT Requirements, specify communications facilities, including those necessary to transmit data from the metering equipment to the TSP, that are necessary for the effective operation of the Plant and the GIF with the TSP System. Such communication facilities shall be included in Exhibit "C." The Generator shall make arrangements to procure and bear the cost of such facilities.

G. Any changes to the meters, telemetry equipment, voltage transformers, current transformers, and associated panels, hardware, conduit and cable, which will affect the data being received by the other Party must be mutually agreed to by the Parties.

H. Each Party will promptly advise the other Party if it detects or otherwise learns of any metering, telemetry or communications equipment errors or malfunctions that require the attention and/or correction by the other Party. The Party owning such equipment shall correct such error or malfunction as soon as reasonably feasible in accordance with ERCOT Requirements.

5.6 System Protection and Other Controls Requirements.

A. Each Party's facilities shall be designed to isolate any fault, or to correct or isolate any abnormality, that would negatively affect the other Party's system or other entities connected to the TSP System.

B. The Generator shall be responsible for protection of its facilities consistent with ERCOT Requirements.

C. Each Party's protective relay design shall incorporate the necessary test switches to perform the tests required in Section 5.6.F. The required test switches will be placed such that they allow operation of lockout relays while preventing breaker failure schemes from operating and causing unnecessary breaker operations and tripping the Generator's units.

D. Recording equipment shall be installed to analyze all system disturbances in accordance with ERCOT Requirements.

E. Each Party will test, operate and maintain System Protection Equipment in accordance with ERCOT Requirements. Each Party will provide reasonable notice to the other Party of any testing of its System Protection Equipment allowing such other Party the opportunity to have representatives present during testing of its System Protection Equipment.

F. Prior to the In-Service Date, and again prior to Commercial Operation, each Party or its agent shall perform a complete calibration test and functional trip test of the System Protection Equipment. At intervals suggested by Good Utility Practice or at intervals described in the ERCOT Requirements if so defined therein, and following any apparent malfunction of the System Protection Equipment, each Party shall perform both calibration and functional trip tests of its System Protection Equipment. These tests do not require the tripping of any in-service generation unit. These tests do, however, require that all protective relays and lockout contacts be activated.

5.7 No Annexation. Any and all equipment placed on the premises of a Party shall be and remain the property of the Party providing such equipment regardless of the mode and manner of annexation or attachment to real property, unless otherwise mutually agreed by the Parties.

ARTICLE 6. OPERATION AND MAINTENANCE

6.1 Operation and Maintenance of Interconnection Facilities. The Parties agree to operate and maintain their systems in accordance with Good Utility Practice, National Electrical Safety Code, the ERCOT Requirements, PUCT Rules and all applicable laws and regulations. Subject to any necessary ISO approval, each Party shall provide necessary equipment outages to allow the other Party to perform periodic maintenance, repair or replacement of its facilities. Such outages shall be scheduled at mutually agreeable times, unless conditions exist which a Party believes, in accordance with Good Utility Practice, may endanger persons or property. No changes will be made in the normal operation of the Point of Interconnection without the mutual agreement of the Parties except as otherwise provided herein. All testing of the Plant that affects the operation of the Point of Interconnection shall be coordinated between the TSP, the Control Area(s) in which the Plant and the TSP are located, and the Generator and will be conducted in accordance with ERCOT Requirements.

6.2 Control Area Notification. At least six months before Trial Operation, the Generator shall notify the TSP in writing of the Control Area in which it will be located. If the Generator elects to be located in a Control Area other than the Control Area in which the TSP is located, all necessary agreements, including but not limited to remote control area generator interchange agreements, if applicable, and appropriate measures under such agreements, shall be executed and implemented prior to the placement of the Plant in the other Control Area. The Parties will

diligently cooperate with one another to enable such agreements to be executed and implemented on a schedule necessary to meet the Trial Operation date specified in Exhibit "B."

6.3 Land Rights and Easements. Terms and conditions addressing the rights of the TSP and the Generator regarding any facilities located on the other Party's property shall be addressed in a separate, duly executed and recorded easement agreement between the Parties. Prior to Commercial Operation, the Parties will mutually agree upon procedures to govern access to each other's property as necessary for the Parties to fulfill their obligations hereunder.

6.4 Service Interruption. The Parties recognize that the interruption of service provisions of the PUCT Rules give TSP the right to disconnect the TSP System from the Plant under the conditions specified therein. The Generator will promptly disconnect the Plant from the TSP System when required by and in accordance with the PUCT Rules and ERCOT Requirements.

6.5 Switching and Clearance.

A. Any switching or clearances needed on the TIF or the GIF will be done in accordance with ERCOT Requirements.

B. Any switching and clearance procedure necessary to comply with Good Utility Practice or ERCOT Requirements that may have specific application to the Plant shall be addressed in Exhibit "C."

6.6 Start-Up and Synchronization. Consistent with ERCOT Requirements and the Parties' mutually acceptable procedure, the Generator is responsible for the proper synchronization of the Plant to the TSP System.

6.7 Routine Operational Communications. On a timely basis, the Parties shall exchange all information necessary to comply with ERCOT Requirements.

6.8 Blackstart Operations. If the Plant is capable of blackstart operations, Generator will coordinate individual Plant start-up procedures consistent with ERCOT Requirements. Any blackstart operations shall be conducted in accordance with the blackstart criteria included in the ERCOT Requirements and the TSP Blackstart Plan on file with the ISO. Notwithstanding this section, the Generator is not required to have blackstart capability by virtue of this Agreement. If the Generator will have blackstart capability, then Generator shall provide and maintain an emergency communication system that will interface with the TSP during a blackstart condition.

6.9 Power System Stabilizers. The Generator shall procure, install, maintain and operate power system stabilizers if required to meet ERCOT Requirements and as described in Exhibit "C."

ARTICLE 7. DATA REQUIREMENTS

7.1 Data Acquisition. The acquisition of data to realistically simulate the electrical behavior of system components is a fundamental requirement for the development of a reliable interconnected transmission system. Therefore, the TSP and the Generator shall be required to submit specific information regarding the electrical characteristics of their respective facilities to each other as described below in accordance with ERCOT Requirements.

7.2 Initial Data Submission by TSP. The initial data submission by the TSP shall occur no later than 120 days prior to Trial Operation and shall include transmission system data necessary to allow the Generator to select equipment and meet any system protection and stability requirements.

7.3 Initial Data Submission by Generator. The initial data submission by the Generator, including manufacturer data, shall occur no later than 90 days prior to the Trial Operation and

shall include a completed copy of the following forms contained in the ISO's Generation Interconnection Procedure: (1) Plant Description/Data and (2) Generation Stability Data. It shall also include any additional data provided to the ISO for the System Security Study. Data in the initial submissions shall be the most current Plant design or expected performance data. Data submitted for stability models shall be compatible with the ISO standard models. If there is no compatible model, the Generator will work with an ISO designated consultant to develop and supply a standard model and associated data.

7.4 Data Supplementation. Prior to Commercial Operation, the Parties shall supplement their initial data submissions with any and all "as-built" Plant data or "as-tested" performance data which differs from the initial submissions or, alternatively, written confirmation that no such differences exist. Subsequent to Commercial Operation, the Generator shall provide the TSP any data changes due to equipment replacement, repair, or adjustment. The TSP shall provide the Generator any data changes due to equipment replacement, repair, or adjustment in the directly connected substation or any adjacent TSP-owned substation that may affect the GIF equipment ratings, protection or operating requirements. The Parties shall provide such data no later than 30 days after the date of the actual change in equipment characteristics. Also, the Parties shall provide to each other a copy of any additional data later required by the ISO concerning these facilities.

7.5 Data Exchange. Each Party shall furnish to the other Party real-time and forecasted data as required by ERCOT Requirements. The Parties will cooperate with one another in the analysis of disturbances to either the Plant or the TSP's System by gathering and providing access to any information relating to any disturbance, including information from oscillography, protective relay targets, breaker operations and sequence of events records.

ARTICLE 8. PERFORMANCE OBLIGATION

- 8.1 Generator's Cost Responsibility. The Generator will acquire, construct, operate, test, maintain and own the Plant and the GIF at its sole expense. In addition, the Generator may be required to make a contribution in aid of construction in the amount set out in and for the facilities described in Exhibit "C," if any, in accordance with PUCT Rules.
- 8.2 TSP's Cost Responsibility. The TSP will acquire, own, operate, test, and maintain the TIF at its sole expense, subject to the provisions of Section 4.1.B and the contribution in aid of construction provisions of Section 8.1 of this Agreement.
- 8.3 Financial Security Arrangements. The TSP may require the Generator to pay a reasonable deposit or provide another means of security, to cover the costs of planning, licensing, procuring equipment and materials, and constructing the TIF. The required security arrangements shall be specified in Exhibit "E." Within five business days after the Plant achieves Commercial Operation, the TSP shall return the deposit or security to the Generator. However, the TSP may retain an amount to cover the incremental difference between the TSP's actual out of pocket costs associated with the choice of Section 4.1.B over Section 4.1.A, pending a final PUCT Order as contemplated in Section 4.1.B(iii). If the Plant has not achieved Commercial Operation within one year after the scheduled Commercial Operation date identified in Exhibit "B" or if the Generator terminates this Agreement in accordance with Section 2.1 and the TIF are not required, the TSP may, subject to the provisions of Section 2.2, retain as much of the deposit or security as is required to cover the costs it incurred in planning, licensing, procuring equipment and materials, and constructing the TIF. If a cash deposit is made pursuant to Exhibit "E," any repayment of such cash deposit shall include interest at a rate

applicable to customer deposits as established from time to time by the PUCT or other Governmental Authority.

ARTICLE 9. INSURANCE

9.1 Each Party shall, at its own expense, maintain in force throughout the period of this Agreement and until released by the other Party the following minimum insurance coverages, with insurers authorized to do business in Texas:

A. Employers Liability and Worker's Compensation Insurance providing statutory benefits in accordance with the laws and regulations of the State of Texas. The minimum limits for the Employer's Liability insurance shall be One Million Dollars (\$1,000,000) each accident bodily injury by accident, One Million Dollars (\$1,000,000) each employee bodily injury by disease, and One Million Dollars (\$1,000,000) policy limit bodily injury by disease.

B. Commercial General Liability Insurance including premises and operations, personal injury, broad form property damage, broad form blanket contractual liability coverage (including coverage for the contractual indemnification) products and completed operations coverage, coverage for explosion, collapse and underground hazards, independent contractors coverage, coverage for pollution to the extent normally available and punitive damages to the extent normally available and a cross liability endorsement, with minimum limits of One Million Dollars (\$1,000,000) per occurrence/One Million Dollars (\$1,000,000) aggregate combined single limit for personal injury, bodily injury, including death and property damage.

C. Comprehensive Automobile Liability Insurance for coverage of owned, non-owned and hired vehicles, trailers or semi-trailers designed for travel on public roads, with a minimum combined single limit of One Million Dollars (\$1,000,000) per occurrence for bodily injury, including death, and property damage.

D. Excess Public Liability Insurance over and above the Employer's Liability, Commercial General Liability and Comprehensive Automobile Liability Insurance coverage, with a minimum combined single limit of Three Million Dollars (\$3,000,000) per occurrence/Three Million Dollars (\$3,000,000) aggregate.

E. The Commercial General Liability Insurance, Comprehensive Automobile Liability Insurance, and Excess Public Liability Insurance policies shall name the other Party, its parent, associated and affiliated companies and their respective directors, officers, agents, servants and employees ("Other Party Group") as additional insured. All policies shall contain provisions whereby the insurers waive all rights of subrogation in accordance with the provisions of this Agreement against the Other Party Group and provide thirty (30) days advance written notice to Other Party Group prior to anniversary date of cancellation or any material change in coverage or condition.

F. The Commercial General Liability Insurance, Comprehensive Automobile Liability Insurance and Excess Public Liability Insurance policies shall contain provisions that specify that the policies are primary and shall apply to such extent without consideration for other policies separately carried and shall state that each insured is provided coverage as though a separate policy had been issued to each, except the insurer's liability shall not be increased beyond the amount for which the insurer would have been liable had only one insured been covered. Each Party shall be responsible for its respective deductibles or retentions.

G. The Commercial General Liability Insurance, Comprehensive Automobile Liability Insurance and Excess Public Liability Insurance policies, if written on a Claims First Made basis, shall be maintained in full force and effect for two (2) years after termination of

this Agreement, which coverage may be in the form of tail coverage or extended reporting period coverage if agreed by the Parties.

H. The requirements contained herein as to the types and limits of all insurance to be maintained by the Parties are not intended to and shall not in any manner, limit or qualify the liabilities and obligations assumed by the Parties under this Agreement.

I. Within thirty (30) days following execution of this Agreement, and as soon as practicable after the end of each fiscal year or at the renewal of the insurance policy and in any event within ninety (90) days thereafter, each Party shall provide certification of all insurance required in this Agreement, executed by each insurer or by an authorized representative of each insurer.

J. Notwithstanding the foregoing, each Party may self-insure to the extent it maintains a self-insurance program; provided that, such Party's senior secured debt is rated at investment grade, or better, by Standard & Poor's. For any period of time that a Party's senior secured debt is unrated by Standard & Poor's or is rated at less than investment grade by Standard & Poor's, such Party shall comply with the insurance requirements applicable to it under Sections 9.1.A through 9.1.I. In the event that a Party is permitted to self-insure pursuant to this Section 9.1.J, it shall not be required to comply with the insurance requirements applicable to it under Sections 9.1.A through 9.1.I.

K. The Parties agree to report to each other in writing as soon as practical all accidents or occurrences resulting in injuries to any person, including death, and any property damage arising out of this Agreement.

ARTICLE 10. MISCELLANEOUS

10.1 Governing Law and Applicable Tariffs.

A. This Agreement for all purposes shall be construed in accordance with and governed by the laws of the State of Texas, excluding conflicts of law principles that would refer to the laws of another jurisdiction. The Parties submit to the jurisdiction of the federal and state courts in the State of Texas.

B. This Agreement is subject to all valid, applicable rules, regulations and orders of, and tariffs approved by, duly constituted Governmental Authorities.

C. Each Party expressly reserves the right to seek changes in, appeal, or otherwise contest any laws, orders, rules, or regulations of a Governmental Authority.

10.2 No Other Services. This Agreement is applicable only to the interconnection of the Plant to the TSP System at the Point of Interconnection and does not obligate either Party to provide, or entitle either Party to receive, any service not expressly provided for herein. Each Party is responsible for making the arrangements necessary for it to receive any other service that it may desire from the other Party or any third party. This Agreement does not address the sale or purchase of any electric energy, transmission service or ancillary services by either Party, either before or after Commercial Operation.

10.3 Entire Agreement. This Agreement, including all Exhibits, Attachments and Schedules attached hereto, constitutes the entire agreement between the Parties with reference to the subject matter hereof, and supersedes all prior and contemporaneous understandings or agreements, oral or written, between the Parties with respect to the subject matter of this Agreement. There are no other agreements, representations, warranties, or covenants which constitute any part of the consideration for, or any condition to, either Party's compliance with its obligations under this Agreement. Notwithstanding the other provisions of this Section, the Facilities Study Agreement, if any, is unaffected by this Agreement.

10.4 Notices. Except as otherwise provided in Exhibit "D," any formal notice, demand or request provided for in this Agreement shall be in writing and shall be deemed properly served, given or made if delivered in person, or sent by either registered or certified mail, postage prepaid, overnight mail or fax to the address or number identified on Exhibit "D" attached to this Agreement. Either Party may change the notice information on Exhibit "D" by giving five business days written notice prior to the effective date of the change.

10.5 Force Majeure.

A. The term "Force Majeure" as used herein shall mean any cause beyond the reasonable control of the Party claiming Force Majeure, and without the fault or negligence of such Party, which materially prevents or impairs the performance of such Party's obligations hereunder, including but not limited to, storm, flood, lightning, earthquake, fire, explosion, failure or imminent threat of failure of facilities, civil disturbance, strike or other labor disturbance, sabotage, war, national emergency, or restraint by any Governmental Authority.

B. Neither Party shall be considered to be in Default (as hereinafter defined) with respect to any obligation hereunder (including obligations under Article 4), other than the obligation to pay money when due, if prevented from fulfilling such obligation by Force Majeure. A Party unable to fulfill any obligation hereunder (other than an obligation to pay money when due) by reason of Force Majeure shall give notice and the full particulars of such Force Majeure to the other Party in writing or by telephone as soon as reasonably possible after the occurrence of the cause relied upon. Telephone notices given pursuant to this Section shall be confirmed in writing as soon as reasonably possible and shall specifically state full particulars of the Force Majeure, the time and date when the Force Majeure occurred and when the Force Majeure is reasonably expected to cease. The Party affected shall exercise due

diligence to remove such disability with reasonable dispatch, but shall not be required to accede or agree to any provision not satisfactory to it in order to settle and terminate a strike or other labor disturbance.

10.6 Default A. The term "Default" shall mean the failure of either Party to perform any obligation in the time or manner provided in this Agreement. No Default shall exist where such failure to discharge an obligation (other than the payment of money) is the result of Force Majeure as defined in this Agreement or the result of an act or omission of the other Party. Upon a Default, the non-defaulting Party shall give written notice of such Default to the defaulting Party. Except as provided in Section 10.6.B, the defaulting Party shall have thirty (30) days from receipt of the Default notice within which to cure such Default; provided however, if such Default is not capable of cure within 30 days, the defaulting Party shall commence such cure within 30 days after notice and continuously and diligently complete such cure within 90 days from receipt of the Default notice; and, if cured within such time, the Default specified in such notice shall cease to exist.

B. If a Default is not cured as provided in this Section, or if a Default is not capable of being cured within the period provided for herein, the non-defaulting Party shall have the right to terminate this Agreement by written notice at any time until cure occurs, and be relieved of any further obligation hereunder and, whether or not that Party terminates this Agreement, to recover from the defaulting Party all amounts due hereunder, plus all other damages and remedies to which it is entitled at law or in equity. The provisions of this Section will survive termination of this Agreement.

10.7 Intrastate Operation. The operation of the Plant by Generator shall not cause there to be a synchronous or an asynchronous interconnection between ERCOT and any other transmission

facilities operated outside of ERCOT unless ordered by the Federal Energy Regulatory Commission under Section 210 of the Federal Power Act. The Parties recognize and agree that any such interconnection will constitute an adverse condition giving the TSP the right to immediately disconnect the TIF from the GIF, until such interconnection has been disconnected. The Generator will not be prohibited by this Section from interconnecting the Plant with facilities operated by the Comision Federal de Electricidad of Mexico, unless such interconnection would cause ERCOT utilities that are not "public utilities" under the Federal Power Act to become subject to the plenary jurisdiction of the Federal Energy Regulatory Commission.

10.8 No Third Party Beneficiaries. This Agreement is not intended to and does not create rights, remedies, or benefits of any character whatsoever in favor of any persons, corporations, associations, or entities other than the Parties, and the obligations herein assumed are solely for the use and benefit of the Parties, their successors in interest and, where permitted, their assigns.

10.9 No Waiver. The failure of a Party to this Agreement to insist, on any occasion, upon strict performance of any provision of this Agreement will not be considered a waiver of obligations, rights, or duties imposed upon the Parties. Termination or Default of this Agreement for any reason by the Generator shall not constitute a waiver of the Generator's legal rights to obtain an interconnection from the TSP under a new interconnection agreement.

10.10 Headings. The descriptive headings of the various articles and sections of this Agreement have been inserted for convenience of reference only and are of no significance in the interpretation or construction of this Agreement.

10.11 Multiple Counterparts. This Agreement may be executed in two or more counterparts, each of which is deemed an original but all constitute one and the same instrument.

10.12 Amendment. This Agreement may be amended only upon mutual agreement of the Parties, which amendment will not be effective until reduced to writing and executed by the Parties.

10.13 No Partnership. This Agreement shall not be interpreted or construed to create an association, joint venture, agency relationship, or partnership between the Parties or to impose any partnership obligation or liability upon either Party. Neither Party shall have any right, power or authority to enter into any agreement or undertaking for, or act on behalf of, or to act as or be an agent or representative of, or to otherwise bind, the other Party.

10.14 Further Assurances. The Parties agree to (i) furnish upon request to each other such further information, (ii) execute and deliver to each other such other documents, and (iii) do such other acts and things, all as the other Party may reasonably request for the purpose of carrying out the intent of this Agreement and the documents referred to in this Agreement. Without limiting the generality of the foregoing, the TSP shall, at the Generator's expense, when reasonably requested to do so by the Generator at any time after the execution of this Agreement, prepare and provide such information in connection with this Agreement (including, if available, resolutions, certificates, opinions of counsel or other documents relating to the TSP's corporate authorization to enter into this Agreement and to undertake the obligations set out herein) as may be reasonably required by any potential lender to the Generator under a proposed loan agreement. The TSP will use commercially reasonable efforts to obtain any opinion of counsel reasonably requested by Generator, but the TSP shall not be in Default of any obligation under this Agreement if the TSP is unable to provide an opinion of counsel that will satisfy any potential lender to the Generator. Specifically, upon the written request of one Party, the other Party shall provide the requesting Party with a letter stating

whether or not, up to the date of the letter, that Party is satisfied with the performance of the requesting Party under this Agreement.

10.15 Indemnification and Liability. The indemnification and liability provisions of the PUCT Rule 25.202(b)(2) or its successor shall govern this Agreement.

10.16 Consequential Damages. OTHER THAN THE LIQUIDATED DAMAGES HERETOFORE DESCRIBED, IN NO EVENT SHALL EITHER PARTY BE LIABLE UNDER ANY PROVISION OF THIS AGREEMENT FOR ANY LOSSES, DAMAGES, COSTS OR EXPENSES FOR ANY SPECIAL, INDIRECT, INCIDENTAL, CONSEQUENTIAL, OR PUNITIVE DAMAGES, INCLUDING BUT NOT LIMITED TO LOSS OF PROFIT OR REVENUE, LOSS OF THE USE OF EQUIPMENT, COST OF CAPITAL, COST OF TEMPORARY EQUIPMENT OR SERVICES, WHETHER BASED IN WHOLE OR IN PART IN CONTRACT, IN TORT, INCLUDING NEGLIGENCE, STRICT LIABILITY, OR ANY OTHER THEORY OF LIABILITY; PROVIDED, HOWEVER, THAT DAMAGES FOR WHICH A PARTY MAY BE LIABLE TO THE OTHER PARTY UNDER ANOTHER AGREEMENT WILL NOT BE CONSIDERED TO BE SPECIAL, INDIRECT, INCIDENTAL, OR CONSEQUENTIAL DAMAGES HEREUNDER.

10.17 Assignment. This Agreement may be assigned by either Party only with the written consent of the other; provided that either Party may assign this Agreement without the consent of the other Party to any affiliate of the assigning Party with an equal or greater credit rating and with the legal authority and operational ability to satisfy the obligations of the assigning Party under this Agreement; and provided further that the Generator shall have the right to assign this Agreement, without the consent of the TSP, for collateral security purposes to aid in providing financing for the Plant, provided that the Generator will require any secured party, trustee or

mortgagee to notify the TSP of any such assignment. Any financing arrangement entered into by the Generator pursuant to this Section will provide that prior to or upon the exercise of the secured party's, trustee's or mortgagee's assignment rights pursuant to said arrangement, the secured creditor, the trustee or mortgagee will notify the TSP of the date and particulars of any such exercise of assignment right(s). Any attempted assignment that violates this Section is void and ineffective. Any assignment under this Agreement shall not relieve a Party of its obligations, nor shall a Party's obligations be enlarged, in whole or in part, by reason thereof. Where required, consent to assignment will not be unreasonably withheld, conditioned or delayed.

10.18 Severability. If any provision in this Agreement is finally determined to be invalid, void or unenforceable by any court having jurisdiction, such determination shall not invalidate, void or make unenforceable any other provision, agreement or covenant of this Agreement; provided that if the Generator (or any third-party, but only if such third-party is not acting at the direction of the TSP) seeks and obtains such a final determination with respect to any provision of Section 4.1.B, then none of the provisions of Section 4.1.B. shall thereafter have any force or effect and the Parties' rights and obligations shall be governed solely by Section 4.1.A.

10.19 Comparability. The Parties will comply with all applicable comparability and code of conduct laws, rules and regulations, as amended from time to time.

10.20 Invoicing and Payment. Unless the Parties otherwise agree (in a manner permitted by applicable PUCT Rules and as specified in writing in an Exhibit "E" attached hereto), invoicing and payment rights and obligations under this Agreement shall be governed by PUCT Rules or applicable Governmental Authority. Invoices shall be rendered to the paying Party at the

address specified on, and payments shall be made in accordance with the requirements of, Exhibit "D."

10.21 Confidentiality.

A. Subject to the exception in Section 10.21.B, any information that a Party claims is competitively sensitive, commercial or financial information under this Agreement ("Confidential Information") shall not be disclosed by the other Party to any person not employed or retained by the other Party, except to the extent disclosure is (i) required by law; (ii) reasonably deemed by the disclosing Party to be required to be disclosed in connection with a dispute between or among the Parties, or the defense of litigation or dispute; (iii) otherwise permitted by consent of the other Party, such consent not to be unreasonably withheld; or (iv) necessary to fulfill its obligations under this Agreement or as a transmission service provider or a Control Area operator including disclosing the Confidential Information to the ISO. The Party asserting confidentiality shall notify the other Party in writing of the information it claims is confidential. Prior to any disclosures of the other Party's Confidential Information under this subsection, or if any third party or Governmental Authority makes any request or demand for any of the information described in this subsection, the disclosing Party agrees to promptly notify the other Party in writing and agrees to assert confidentiality and cooperate with the other Party in seeking to protect the Confidential Information from public disclosure by confidentiality agreement, protective order or other reasonable measures.

B. This provision shall not apply to any information that was or is hereafter in the public domain (except as a result of a breach of this provision).

Exhibit "B"
Time Schedule

Interconnection Option chosen by Generator (check one): Section 4.1.A. or Section 4.1.B

If Section 4.1.B is chosen by Generator, the In-Service Date(s) was determined by (check one):
(1) good faith negotiations, or (2) Designated by Generator upon failure to agree.

Date by which Generator must provide notice to proceed with design and procurement and provide security, as specified in Section 4.2, so that TSP may maintain schedule to meet the In-Service Date: June 24, 2011

Date by which Generator must provide notice to commence construction and provide security, as specified in Section 4.3, so that TSP may maintain schedule to meet the In-Service Date: June 24, 2011

In - Service Date: May 31, 2012

(Notes: (1) In the event that it is not necessary for all facilities associated with the TIF to be completed on the same date, this entry may consist of multiple dates to reflect the staged completion of the TIF to meet those needs. (2) In-Service Date(s) can be expressed as either a specific date or expressed as a defined number of months after all conditions under Sections 4.2 and 4.3 have been satisfied.)

Scheduled Trial Operation Date: June 1, 2012

Scheduled Commercial Operation Date: June 30, 2012

Due to the nature of the subject of this Agreement, the Parties may mutually agree to change the dates and times of this Exhibit B.

Exhibit "C"
Interconnection Details

1. Name: Kimbro Substation
2. Point of Interconnection location: The Point of Interconnection is located off the intersection of Manda Carlson Road and Sandeen Road in Travis County, Texas. The Point of Interconnection shall be the physical point where the LCRA TSC Kimbro Substation facilities are connected to the Generator facilities. This point is more specifically defined as being located at the 4-hole spade terminals on the dead-end assembly where the Generator's line connects to the LCRA TSC's interconnect structure.
3. Delivery Voltage: 138kV
4. Number and size of Generating Units ("The Plant"): The Plant is a solar generation facility with one Point of Interconnection to the grid. The Plant rating will be approximately 54 MW of AC power at the Point of Interconnection. The Plant will consist of 60.2 MW DC from approximately 430,000 solar panels, each with approximately 140 Watt (DC) capacity per panel.
5. Type of Generating Unit: Solar Photovoltaic (PV) panels
6. Metering and Telemetry Equipment:
 - a. ERCOT settlement metering will be located at the TSP Substation as part of the TSP Interconnection Facilities. 138 kV extended range metering current transformers will be used to accurately read the generation energy and power delivered to the grid and the auxiliary energy and power consumed when the generation is offline. 138 kV metering accuracy class voltage transformers will also be installed by the TSP for the ERCOT settlement metering. The ERCOT settlement metering panel furnished by the TSP will be located in the TSP Substation.
 - b. A multi-ported remote terminal unit (RTU) will be furnished by the TSP at the TSP Substation as part of the TIF and will have a dedicated communication port available to provide applicable breaker status, energy and other telemetered data to the Generator's monitoring and control systems. The Generator is responsible for determining and providing all their RTU communications needs.
 - c. Multi-ported RTU(s) will be furnished by the Generator at the Generator's interconnection substation(s) as part of the GIF and will have dedicated communication port(s) available to provide breaker status, energy and other telemetered data to the

TSP's monitoring and control systems to meet the TSP's needs. The Generator will provide communication path(s) for the TSP's port(s) as described in Item 9 below.

7. **Generator Interconnection Facilities:** The Generator will provide as a minimum, the following major equipment for the Generator Interconnection Facilities:
- A 477 ACSR conductor 138 kV line approximately 100 ft. in length with single-mode, 24 pair, fiber optics (OPGW) shield wire and necessary material to dead-end and connect to TSP's interconnect structure at the TSP Substation
 - A full tension, dead-end, 138 kV line structure located near the TSP Substation property line
 - 138 kV slack span from the Generators full tension dead-end to the TSP's interconnect structure
 - Generator's interconnection substation(s) including 138 kV step-up transformer(s), transformer protection package(s), 138 kV circuit breaker(s), 138 kV line disconnect switch(es), and protective relaying panels for the Generator's 138 kV line that will coordinate with the TSP's line panels at the TSP Substation for the Generator line protection
 - Multi-ported RTU(s) and panels to provide breaker status, telemetry and energy data from the Generator's interconnection substation(s) to the Plant, the TSP, Generator and ERCOT
 - Fiber optic cable (24 pair, single-mode, fiber optics OPGW) or other data communications link acceptable to TSP from Generator's interconnection substation(s) control building to the TSP Substation control building complete with OPGW splice cable boxes, facility entry cable and fiber patch panels on each end for fiber utilization by both Generator and TSP
 - Associated structures, buswork, conductor, connectors, grounding, conduit, control cable, foundation work, perimeter fencing, grading/dirt work and any appurtenances necessary for construction and operation of Generator Interconnection Facilities

Generator data submitted in accordance with Section 7.3 of Exhibit "A" shall include, but not be limited to, (1) a detailed one-line diagram of the proposed Plant and Generator Interconnection Facilities showing the collector buses and their voltages, (2) conductor types and lengths of all transmission lines connecting the collector buses to the TSP Substation, (3) the total number of solar panels to be served by each collector bus, (4) size, make and model of individual solar panels, (5) the locations (electrical) and control settings of all reactive equipment connected to the Plant and GIF, and (6) the impedance and rating data of each transmission line, GSU and/or autotransformer that will be installed to get power from the Plant and onto the transmission grid.

The above list is not intended to be a complete list of all facilities that are part of the GIF.

8. **Transmission Service Provider Interconnection Facilities:** The TIF shall consist of the following:

TSP Substation: TSP will provide as a minimum, the following major equipment in the TSP Substation:

- ERCOT settlement metering panel
- 3-138 kV Extended Range Metering CT's
- 3-138 kV Metering Class Voltage Transformers
- Dead-end substation structure (TSP's interconnect structure) within TSP Substation for Generator's 138 kV slack span line termination
- 138 kV circuit breakers, line surge arresters, switches and protective relaying panels at the TSP Substation for the Generator's 138 kV transmission line
- A multi-ported RTU and associated panels, to provide TSP and Generator with certain breaker status, telemetry and energy data from the TSP Substation
- 138 kV transmission line termination equipment for circuits from adjacent stations, including 138 kV circuit breakers, switches, 138 kV CCVT's for relaying with carrier coupling, line traps, line tuner, surge arresters, and line relay panels
- Control house with 125 VDC battery sets and associated indoor accessories
- Substation land with provisions as noted in Item 12 below
- All galvanized steel structures, including dead-ends, switch stands, metering instrument structures, surge arrester supports, CCVT supports, line trap supports, static masts, and bus supports necessary for construction and operation of the TSP Substation facilities
- Associated structures, buswork, conductor, connectors, grounding, conduit, control cable, foundation work, perimeter fencing, grading/dirt work and any appurtenances necessary for construction and operation of the TIF

138 kV transmission line changes: Cut-in for existing Merrimack 1433.6 ACSS single 138 kV circuit into the Substation.

The above lists are not intended to be complete lists of all facilities that are part of the TIF.

9. **Communications Facilities:** Generator shall, in accordance with ERCOT Requirements and Good Utility Practice, provide communications facilities that are, or may in the future be, necessary for effective interconnected operation of the Plant and Generator Interconnection Facilities with the transmission system. The Generator will provide fiber optic communication facilities between the Generator's interconnection substation(s) and the TSP Substation complete with cable splice boxes, facility entry cable and fiber patch panels on both ends for utilization by both Generator and TSP. The Generator will provide the dedicated channels or fiber pairs for necessary items including Generator's 138 kV transmission line protective relaying, RTU port(s) for TSP, telemetry and voice communications. Voice communications provided by the Generator shall at a minimum include one full business voice circuit in the Generator's interconnection substation(s) control building.
10. **System Protection Equipment:** The Plant and the Generator Interconnection Facilities shall be designed to isolate any fault, or to disconnect from or isolate any abnormality, that would negatively affect the ERCOT system. The Generator shall be

responsible for protection of its facilities. In particular Generator shall provide relays, circuit breakers, and all other devices necessary to promptly remove any fault contribution of the generation equipment to any short circuit occurring on the TSP system. Such protective equipment shall include, without limitation, a disconnect device or switch with the appropriate interrupting capability to be located within the Generator Interconnection Facilities and the TSP Interconnection Facilities at a site mutually agreed by both Parties. In addition to faults within the Plant and the Generator Interconnection Facilities, Generator shall be responsible for protection of such facilities from such conditions as negative sequence currents, over or under frequency, sudden load rejection, over or under voltage, generator loss of field, inadvertent energization (reverse power) and uncleared transmission system faults.

The Plant and the Generator Interconnection Facilities shall have protective relaying that is consistent with the protective relaying criteria described in the ERCOT Requirements and NERC standards. If reasonably requested by the TSP, Generator shall, at its expense, provide corrections or additions to existing control and protective equipment required to protect the ERCOT system or to comply with government, industry regulations, or standard changes.

The Generator's protective relay design shall incorporate the necessary test switches to enable complete functional testing. The required test switches will be placed such that they allow operation of lockout relays while preventing breaker failure schemes from operating and causing unnecessary breaker operations and tripping generator units.

Generator shall install sufficient digital fault recording equipment to thoroughly analyze all system disturbances of the generation system. This equipment shall monitor the voltages at major nodes of the system, current at major branches, breaker and switch positions, and enough of the DC logic in the relay control scheme to analyze a system disturbance. The TSP shall provide for digital fault recording equipment in the transmission substation. The digital fault recording for both Generator and TSP shall be consistent with the disturbance monitoring requirements described in the ERCOT Requirements and NERC standards

Prior to modifying any relay protection system design or relay setting involving the connecting facilities between the two Parties, Generator shall submit the proposed changes to the TSP for review and approval. TSP's review and approval shall be for the limited purpose of determining whether such proposed changes are compatible with the ERCOT transmission system.

In accordance with Good Utility Practice and ERCOT and NERC standards, the TSP shall determine requirements for protection of the Point of Interconnection and the zone of protection around the Point of Interconnection and shall specify and implement protection and control schemes as necessary to meet such requirements. Generator shall have the right to review and comment on the necessary protection requirements, and such comments shall not be unreasonably refused by the TSP when determining such requirements. The TSP shall coordinate the relay system protection between Generator and the ERCOT system.

11. Inputs to Telemetry Equipment: Breaker status, protection status, watts, VARs, voltage and current.

12. Supplemental Terms and Conditions:

A) Device Numbers, Switching and Clearance:

(a) Generator shall obtain prior approval of the TSP before operating any circuit switching apparatus (e.g. switches, circuit breakers, etc.) at the Generator Interconnection Facilities, whether for testing or for operations of the Plant, which approval shall not be unreasonably withheld.

(b) The TSP shall direct all switching at the Point of Interconnection. Each party shall perform all transmission operator functions for their facilities. In the event the Generator desires to have the ability to operate any directly connected TSP facilities for emergency operations switching, the TSP will provide Generator with a copy of the TSP's transmission operations procedure manual ("Red Book") and any subsequent amendments thereto. The TSP will provide transmission switching training to Generator personnel. Generator personnel or their designated agents that are to perform switching of the Generator Interconnection Facilities must be on the TSP authorized switching list. Generator and the TSP agree to conduct all switching operations of any directly connected TSP facilities in accordance with the Red Book, as it may be changed by the TSP from time to time.

(c) Generator and TSP will collaborate and reach mutual agreement on the establishment of: i) unique name(s) for the Generator's substations, unit main transformers and switching station(s) connected at transmission voltage; ii) device numbers for all transmission voltage level switches and breakers which will be owned by Generator; and iii) unique names for Generator's generating units, in accordance with ERCOT Requirements. Generator will submit to TSP, within thirty (30) days after execution of this Agreement, its proposed name(s), as referenced in this paragraph. Generator will register the name(s) of the facilities specified in this paragraph and Generator-owned device numbers at ERCOT, in accordance with ERCOT Requirements, and such names and device numbers will be consistent with the names and numbers mutually agreed upon pursuant to this paragraph. Generator will not change any of the names or device numbers, established pursuant to this paragraph, without written approval of TSP. Generator will label the devices, referenced in item (ii) above, with the numbers assigned to such devices.

(d) Each Party will keep records of maintenance and switching operations of control and protective equipment associated with this interconnection and will allow the other Party reasonable access to inspect such records.

B) No Retail Sale of Electricity to Generator by TSP: TSP considers the energy and power that the Plant and Generator Interconnection Facilities may from time to time consume from the 138 kV ERCOT grid through the Point of Interconnection to be a retail transaction and as such, the TSP does not intend to be the provider of this retail service. Generator shall make necessary arrangements with the appropriate retail supplier for the energy and power that the Plant and Generator Interconnection Facilities may consume from the 138 kV ERCOT grid through the Point of Interconnection.

C) Notification:

(a) Upon written request from TSP, Generator shall notify the TSP in writing as to which ERCOT Qualified Scheduling Entity the Plant will be scheduling through.

(b) Upon written request from TSP, Generator shall supply notification to the TSP identifying their retail service provider(s) 60 days prior to the In-Service Date and Generator shall supply notification to the TSP 60 days prior to any changes in retail service provider, thereafter.

D) Substation Land, Easements and Access Road Provisions:

(a) TSP shall specify substation land location and requirements for the TSP substation (substation location generally depicted in Exhibit "C3"). Generator shall, at no cost to TSP, deliver to TSP no later than June 24, 2011 ownership special warranty deed, in a form acceptable to TSP, conveying good and indefeasible title to the real property designated as the LCRA TSC Substation and access road ("Substation Site"). Said conveyance shall be subject to review and acceptance of the survey, title research, and environmental assessment of the Substation Site by TSP. In no event shall the property be subject to any lien or any other encumbrance (including, without limitation, the right of the owner of the mineral estate to use the surface of the Substation Site), or restriction unacceptable to TSP. The Substation Site must include good and adequate rights of vehicular ingress and egress to and from Manda Carlson Road and provide for access rights for necessary utility services and communication services.

(b) Generator agrees to prepare the surveys and legal descriptions of the Substation Site, such surveys to be prepared to the specifications of TSP.

(c) Generator shall be responsible for all transaction costs related to conveyance of the Substation Site to TSP including, without limitation, roll back taxes, title insurance premium, survey costs, and any costs incurred in clearing liens or other encumbrances. This obligation shall survive the closing of the conveyance of the Substation Site.

13. **Special Operating Conditions, if any, attached:**

A) **Quality of Power.** Generator shall provide a quality of power into the TSP system consistent with the applicable ERCOT Requirements and NERC guidelines.

B) **Harmonics.** The Generator's alternating current generating system must have a frequency of 60 Hz, be designed for balanced three-phase operation, not cause unreasonable imbalance on the ERCOT system or the TSP Substation equipment, and adhere to the recommendations in Institute of Electrical and Electronic Engineers Recommended Practices and Requirements for Harmonic Control in Electrical Power Systems (IEEE 519), or its successor.

C) **Voltage, Frequency and Reactive Support.**

(a) Generator shall have and maintain the reactive capability as required in the ERCOT Requirements which are subject to change by ERCOT.

(b) All electric power and energy generated at the Plant and delivered to

the TSP shall have a nominal frequency of 60 Hertz ("Hz") and shall have the precise frequency, voltage and other properties and characteristics from time to time established by the TSP for operation of its system.

(c) The Generator shall be equipped with both frequency and voltage controls and shall be operated in synchronism with the TSP's system with such controls in service. Generator shall notify the TSP at any such time that such controls are out of service.

D) ERCOT Operating Arrangements. A special ERCOT-approved operating arrangement such as a Remedial Action Plan or Special Protection System may be required either prior to, or after, Commercial Operation. The terms "Remedial Action Plan" and "Special Protection System" shall have the meanings as set forth in the ERCOT Requirements. TSP and ERCOT will examine the need and feasibility of these arrangements in cooperation with the Generator. In the event that ERCOT determines that such an arrangement is required, then TSP, ERCOT, and Generator will cooperate to design and install the necessary facilities, to be operational for the duration of the period where such Remedial Action Plan or Special Protection System may be necessary. This Agreement will be amended to document such arrangement.

E) Back-up Power during Point of Interconnection Outage. The Generator acknowledges that this Point of Interconnection may not always be available due to maintenance or other outage activities and at these times of unavailability the loss of both generator output and power delivery to the Generator will not be the responsibility of the TSP. The Generator is responsible for providing any back-up power sources that it may require due to the unavailability of this Point of Interconnection for any period of time.

Exhibit "C1"

Point of Interconnect Detail

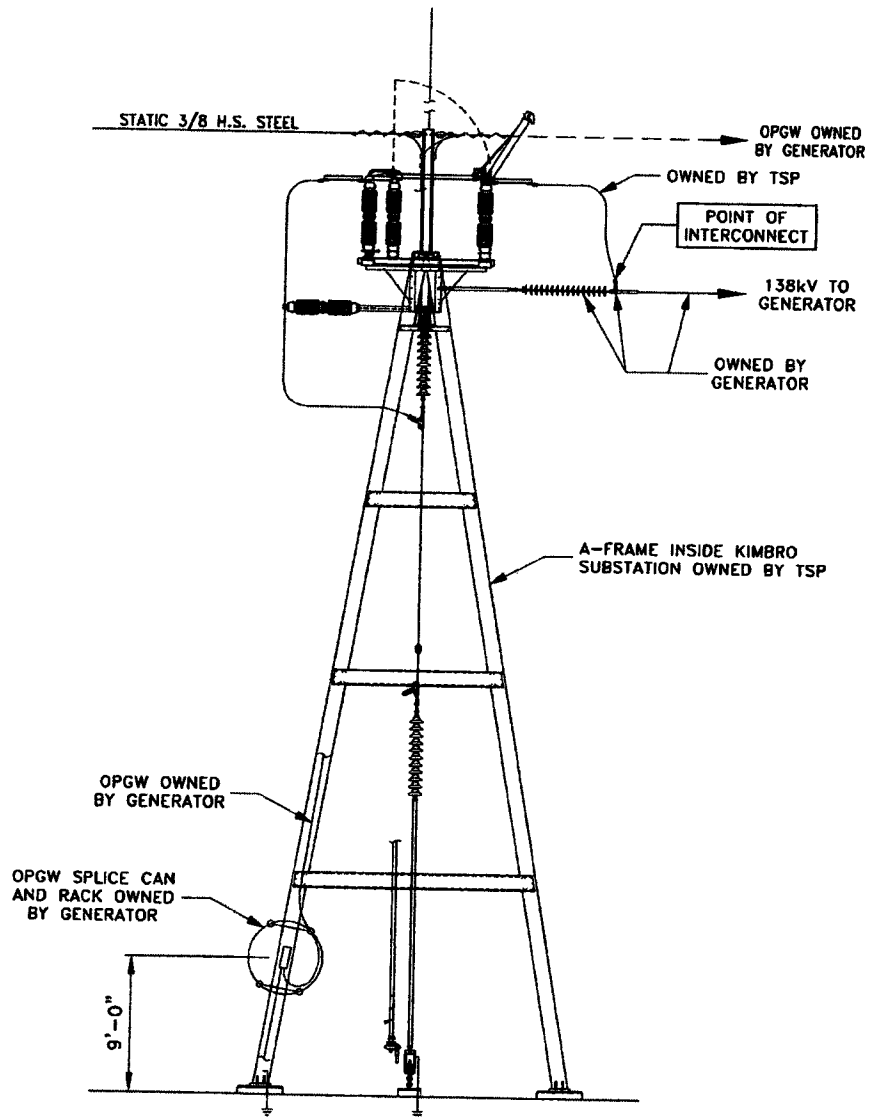
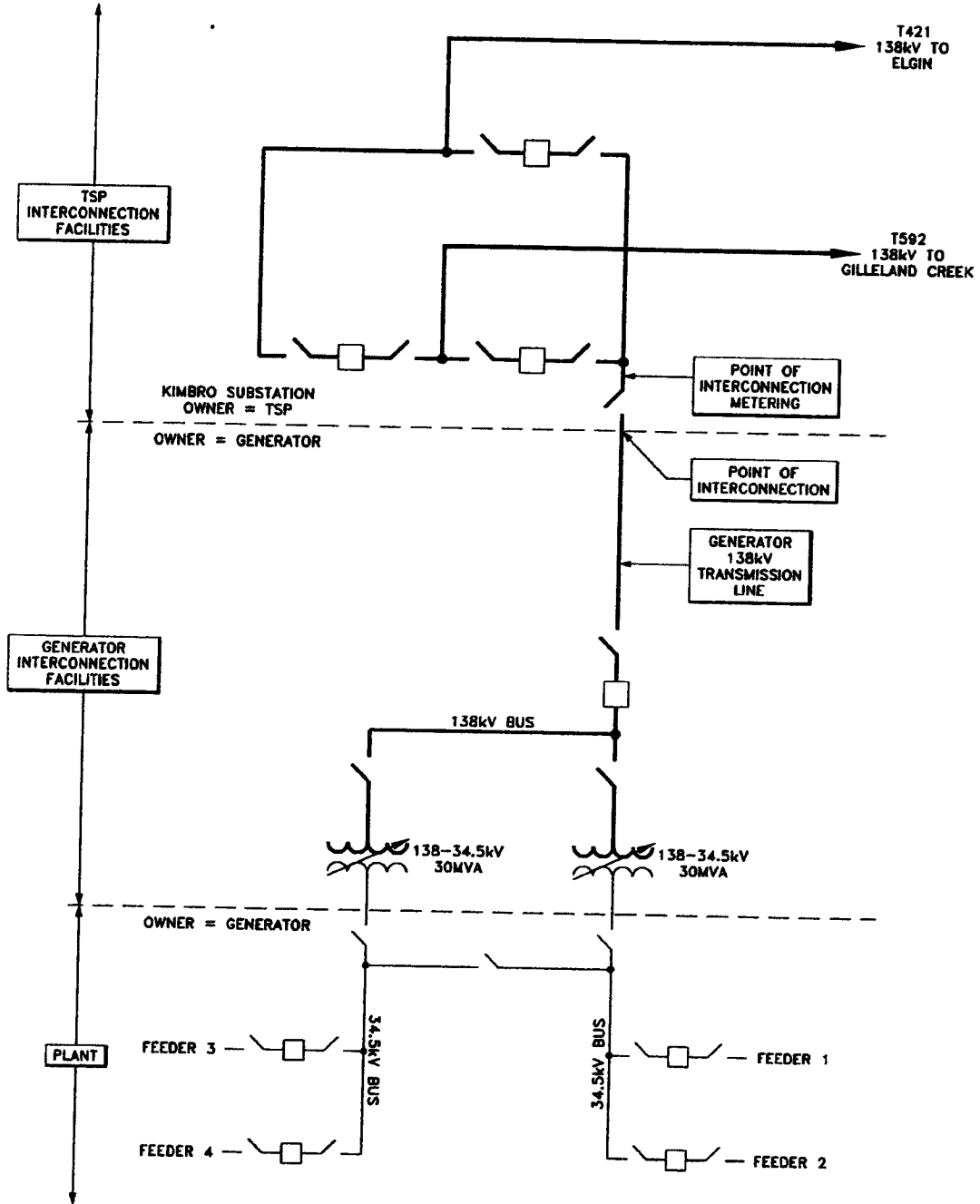

Exhibit "C2" TIF and GIF One-Line Diagram



MANDA CARLSON ROAD (60' R.O.W.)

N27°05'40"E 1308.00'
(N30°08'15"E 1307.68')

78.133 ACRES
KEIVAN AND REGINA KESHVARI
VOL. 12349, PG. 2127
ROBERT FLETCHER SURVEY NO. 69, ABSTRACT NO. 287

LCRA TSC Kimbro Substation Property and Access Road
Exhibit "C3"

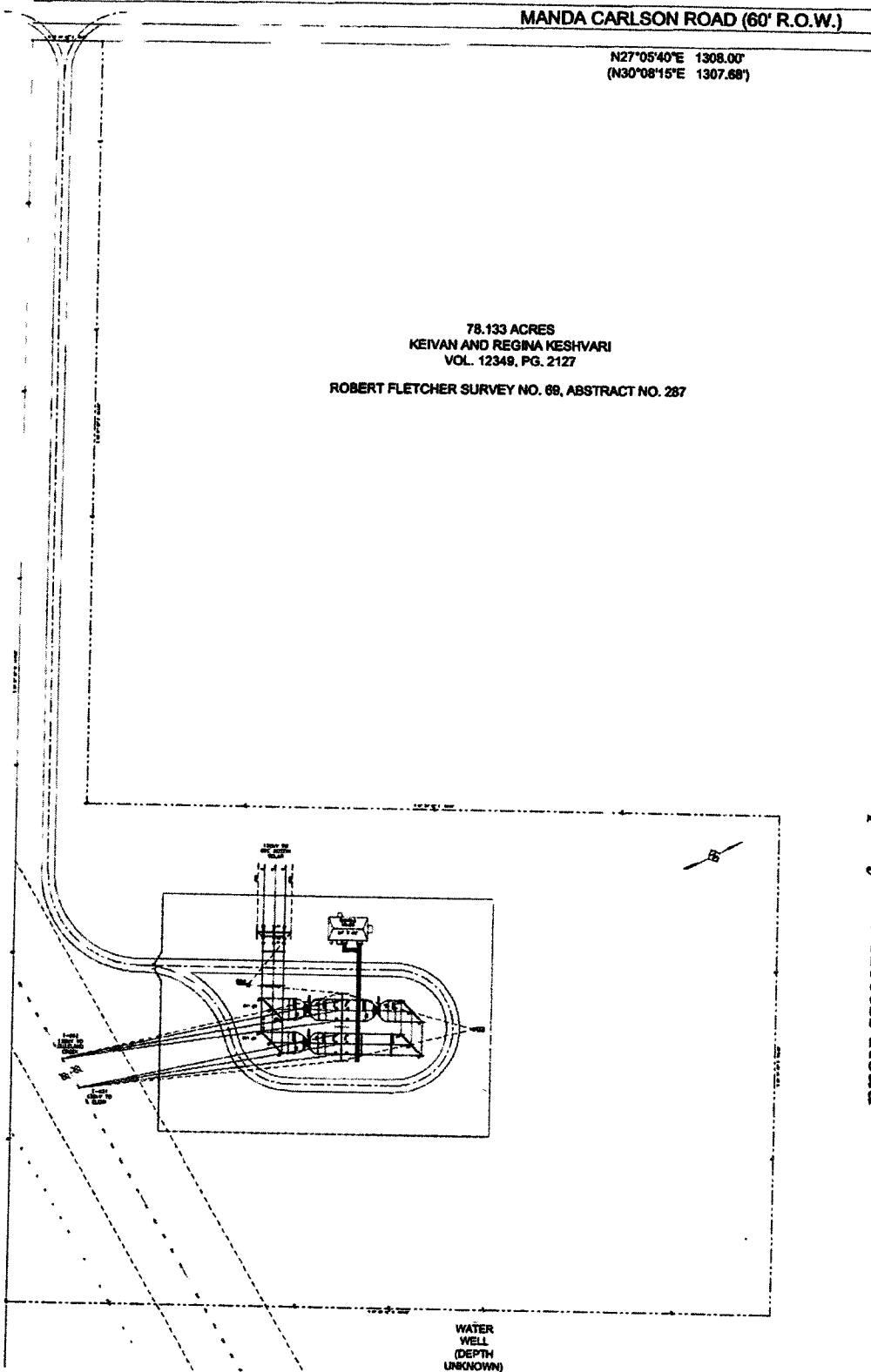

Exhibit "C4" Substation Location

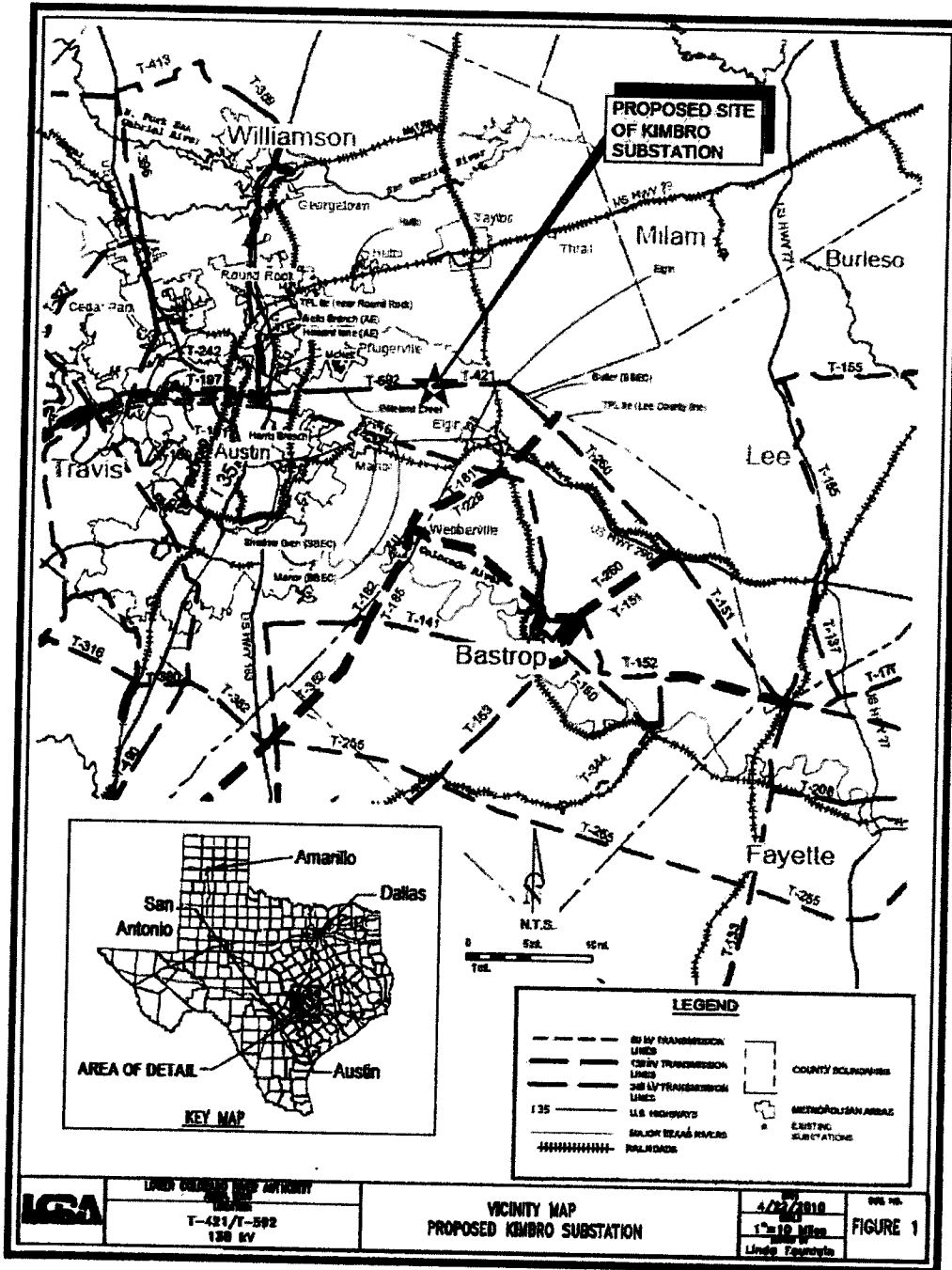

Exhibit "D"
**Notice and EFT Information of the ERCOT Standard Generation
Interconnection Agreement**

(a) All notices of an operational nature shall be in writing and/or may be sent between the Parties via electronic means including facsimile as follows:

If to RRE Austin Solar, LLC

Company Name: RRE Austin Solar, LLC
Attn: Daven Mehta, CEO
8121 Bee Cave Road, Suite 100
Austin, TX 78746
Operational/Confirmation Fax: (512) 382-7525
24 Hour Telephone: (512) 382-5316
E-mail: Daven@rresolar.com

To: LCRA Transmission Services Corporation

Company Name: LCRA
Attn: Transmission Operations Manager
P.O.Box 220
Austin, TX 78767
Operational/Confirmation Fax: (512) 385-2146
24 Hour Telephone: 1 (800) 223-7622
E-mail: bill.hatfield@lcra.org

(b) Notices of an administrative nature:

To: RRE Austin Solar, LLC

Company Name: RRE Austin Solar, LLC
Attn: Valerie Harkins, Site Coordinator
8121 Bee Cave Road, Suite 100
Austin, TX 78746
Fax: (512) 382-7525
Phone: (512) 382-5316
E-mail: Valerie@rresolar.com

To: LCRA Transmission Services Corporation

Company Name: LCRA
Attn: Transmission Engineering Manager
P.O.Box 220
Austin, TX 78767
Fax (512) 369-4413
Phone: (512) 369-4534
E-mail: ray.pfefferkorn@lcra.org

(c) Notice for statement and billing purposes:

To: RRE Austin Solar, LLC

Company Name RRE Austin Solar, LLC
Attn: Hiren Mehta, CFO
Address: 8121 Bee Cave Road, Suite 100
Austin, TX 78746
Fax: (512) 382-7525
Phone: (512) 382-5316
E-mail: Hiren@rresolar.com

To: LCRA Transmission Services Corporation

Company Name: (Same as (b) above)
Attn:
Address
City, State, Zip
Fax:
Phone:
E-mail:

(d) Information concerning Electronic Funds Transfers:

To: RRE Austin Solar, LLC

Bank Name: ---N/A---
City, State
ABA No. _____
for credit to _____
Account No. _____

To: LCRA Transmission Services Corporation

Bank Name: ---N/A---
ABA No. _____
for credit to _____
Account No. _____

Exhibit "E"
Security Arrangement Details

In accordance with the dates in Exhibit "B" Generator shall cause to be established pursuant to Section 8.3 of Exhibit "A", and shall at all times through the earlier of (i) five (5) Business Days after the date upon which TSP receives written notification from Generator that Commercial Operation has been achieved or (ii) ninety (90) days after the termination of the Agreement in accordance with its terms (the earlier of which shall be the "Final Expiration Date"), cause to be maintained in full force and effect a Letter of Credit or other security reasonably acceptable to TSP ("Security Instrument") for the benefit of TSP in a commercially acceptable form consistent with this Exhibit "E" and otherwise acceptable to TSP and Generator, which acceptance shall not be unreasonably withheld, in the amounts and for the periods set forth below. If the Security Instrument is not a Letter of Credit then the Parties agree to amend this Exhibit "E" of this Agreement to include the form of the Security Instrument. Failure to deliver the Security Instrument by June 24, 2011 as contemplated in Exhibit "B" shall be deemed a Default under Section 10.6 of the Agreement, notwithstanding any cure period otherwise provided for in Section 10.6.

The Letter of Credit shall consist of one letter of credit as shown in the table below, which shall be effective in accordance with the date in Exhibit "B". Business Day means any day other than a Saturday, a Sunday, or a holiday on which national banking associations in the State of Texas are permitted or required to be closed. Notwithstanding the Expiration Dates there shall be no obligation by the Generator to establish or maintain any letter of credit after the Final Expiration Date and any letter of credit outstanding as of the Final Expiration Date shall be immediately surrendered by TSP for cancellation.

The maximum stated amounts, Extension Dates and Expiration Dates of the letters of credit shall be as follows:

| Maximum Stated Amount | Extension Date | Expiration Date |
|------------------------------|-----------------------|------------------------|
| \$,3,574,000. | N/A | October 1, 2013 |

Failure to deliver or maintain a Letter of Credit within the time period specified above shall be deemed a Default under Section 10.6 of the Agreement, notwithstanding any cure period otherwise provided for in Section 10.6.

"Letter of Credit" shall mean an irrevocable, transferable letter of credit, issued by a Generator-selected and TSP-approved (which approval shall not be unreasonably withheld), major U.S. commercial bank or a major foreign commercial bank with a U.S. branch office with a credit rating of at least "A-" by Standard & Poor's or "A3" by Moody's Investor Service ("Bank"). A Bank approved by TSP for the initial Letter of Credit shall be deemed approved for a subsequent Letter of Credit absent any adverse change in credit rating between the effective date and the Extension Date for such subsequent Letter of Credit. An adverse change in credit rating shall be deemed to have occurred if the issuer of the then current Letter of Credit has a credit rating of less than "A-" by Standard & Poor's or "A3" by Moody's Investor Service. If

the issuer of the current Letter of Credit suffers such adverse change in credit rating, it shall no longer be a TSP-approved Bank for purposes of issuing commercially acceptable security for this Agreement until its rating has been increased to at least "A-" by Standard & Poor's or "A3" by Moody's Investor Service.

If at any time during the term of this Agreement, the TSP-approved bank which has issued the then current Letter of Credit suffers a credit rating reduction to less than "A-" by Standard & Poor's or "A3" by Moody's Investor Service, Generator shall replace that Letter of Credit with another Letter of Credit of the same amount and with the same beneficiary from another TSP-approved bank of Generator's choice within fifteen Business Days of the date of such reduction in rating. Failure to deliver a replacement Letter of Credit within fifteen Business Days of the date of a reduction in rating shall be deemed a Default under Section 10.6 of the Agreement, notwithstanding any cure period otherwise provided for in Section 10.6.