

- 1.2.2.1.7. Megawatts and megavars for each transformer (3Ø), either on the high side or the low side.
- 1.2.2.2. Status data from Plant
  - 1.2.2.2.1. Status of the transmission voltage circuit breakers.
  - 1.2.2.2.2. Status of all low-side circuit breakers for feeders and reactive support equipment.
  - 1.2.2.2.3. Status of generator automatic voltage regulator (automatic and manual).
- 1.2.3. A separate CNP SCADA RTU serial communication port shall be used to provide data to the customer upon customer's request. CNP shall provide to the customer the following signals originating at CNP's substation:
  - 1.2.3.1. Analog data from CNP
    - 1.2.3.1.1. Kilovolts for the Point of Interconnection (AØ scaled as a line-to-line value).
  - 1.2.3.2. Status data from CNP
    - 1.2.3.2.1. Status of transmission voltage circuit breakers associated with the generator lead(s).
    - 1.2.3.2.2. Alarm for failure of Pilot Wire/fiber optic relaying communication channels, if applicable.
- 1.2.4. Real-time telemetry data from ERCOT-Polled Settlement (EPS) meters and revenue meters shall not be shared with the customer through the CNP SCADA RTU or through direct connection(s).
- 1.2.5. All applicable data listed in this section shall be provided continuously to CNP Real Time Operations (RTO), whether through a CNP-owned RTU, through CNP-connected communication ports, or customer-owned SCADA RTU ports. CNP's periodicity for scanning the data from established communication ports and SCADA RTU ports shall be set in accordance with the Electric Reliability Council of Texas (ERCOT) requirements.
- 1.2.6. The customer shall provide plant data to ERCOT according to ERCOT requirements. CNP is not responsible for providing the customer plant data to ERCOT.

CenterPoint Energy Houston Electric		
WRITTEN	12/30/03	C.W. Mogannam
CHECKED	12/30/03	R.M. Secrest
APPROVED	12/30/03	M.W. Furnish
Page 4 of 15		
SPC	007	400 02

## SECTION 2 UTILITY INTERCONNECTION

### 2.1. Typical interconnection arrangement

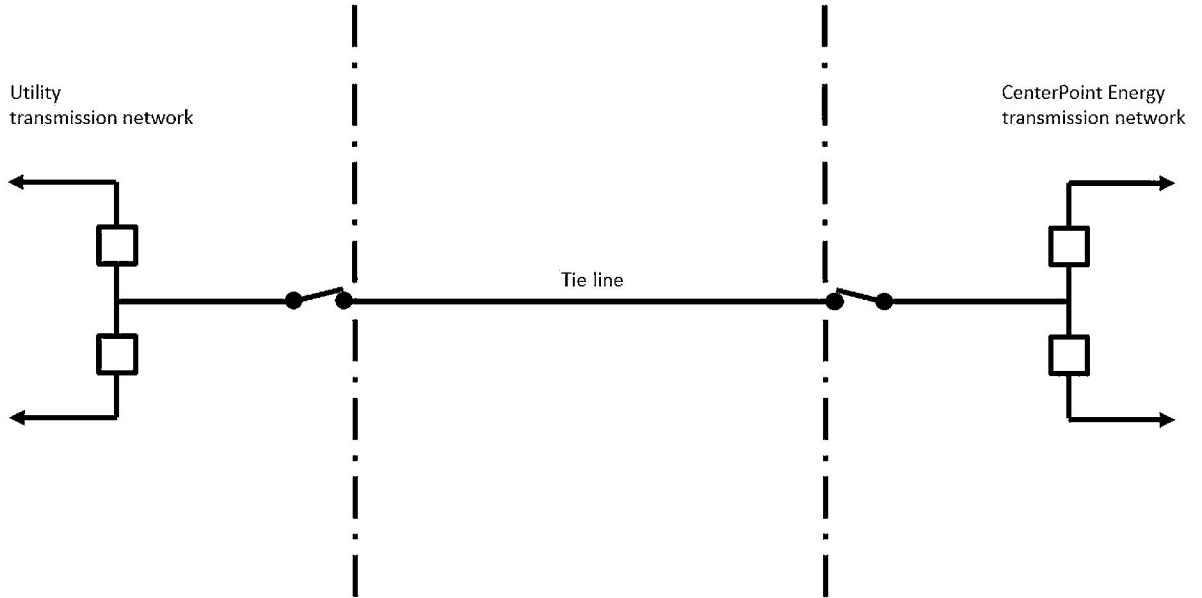

**Figure 2 – Typical Utility interconnection arrangement**

### 2.2. General SCADA requirements

2.2.1. SCADA communication options, as agreeable between Utility and CNP:

- 2.2.1.1. If there is a fiber optic cable between Utility’s substation and CNP’s substation, CNP shall obtain Utility’s data via fiber utilizing **DNP3 serial** protocol.
- 2.2.1.2. Where fiber optic cable is not available, Utility shall reserve a serial port with DNP3 serial protocol of Utility’s RTU/DCS at the Utility’s substation for CNP use. CNP shall connect a communication circuit to the reserved port of Utility’s RTU/DCS to obtain data.
- 2.2.1.3. If none of the above options is available, CNP shall install a CNP-owned SCADA RTU with communication circuit to CNP RTO at the Utility’s substation. More details of the CNP-owned SCADA RTU are in Section 3 of this specification.

2.2.2. Utility shall provide to CNP the following signals originating at Utility’s substation:

- 2.2.2.1. Analog data from Utility
  - 2.2.2.1.1. Kilovolts at the tie point(s) ( $A\emptyset$  scaled as a line-to-line value).
  - 2.2.2.1.2. Megawatts and Megavars for all transmission lines ( $3\emptyset$ ).

<b>CenterPoint Energy Houston Electric</b>		
<b>WRITTEN</b>	12/30/03	C.W. Mogannam
<b>CHECKED</b>	12/30/03	R.M. Secrest
<b>APPROVED</b>	12/30/03	M.W. Furnish
Page 5 of 15		
SPC	007	400 02



- 2.2.2.1.3. Megavars for all reactive devices.
- 2.2.2.2. Status data from Utility
  - 2.2.2.2.1. Status of the transmission voltage circuit breakers at the tie line voltage.
- 2.2.3. A separate CNP SCADA RTU serial communication port shall be used to provide data to Utility upon Utility's request. CNP shall provide to Utility the following signals originating at CNP's substation:
  - 2.2.3.1. Analog data from CNP
    - 2.2.3.1.1. Kilovolts for the Point of Interconnection (AO scaled as a line-to-line value).
  - 2.2.3.2. Status data from CNP
    - 2.2.3.2.1. Status of transmission voltage circuit breakers associated with the tie line(s).
    - 2.2.3.2.2. Alarm for failure of the tie line Pilot Wire/Fiber optic relaying communication channels, if applicable.
- 2.2.4. Real-time telemetry data from ERCOT-Polled Settlement (EPS) meters and revenue meters shall not be shared with the customer through the CNP SCADA RTU or through direct connection(s).
- 2.2.5. All applicable data listed in this section shall be provided continuously to CNP Real Time Operations (RTO), whether through a CNP-owned RTU, through CNP-connected communication ports, or customer-owned SCADA RTU ports. CNP's periodicity for scanning the data from established communication ports and SCADA RTU ports shall be set in accordance with the Electric Reliability Council of Texas (ERCOT) requirements.
- 2.2.6. Utility shall provide data to ERCOT according to ERCOT requirements. CNP is not responsible for providing Utility's substation data to ERCOT

CenterPoint Energy Houston Electric		
WRITTEN	12/30/03	C.W. Mogannam
CHECKED	12/30/03	R.M. Secrest
APPROVED	12/30/03	M.W. Furnish
Page 6 of 15		
SPC	007	400 02

### SECTION 3

## CUSTOMER-OWNED LOAD TRANSMISSION SUBSTATION

### 3.1. Typical interconnection arrangements

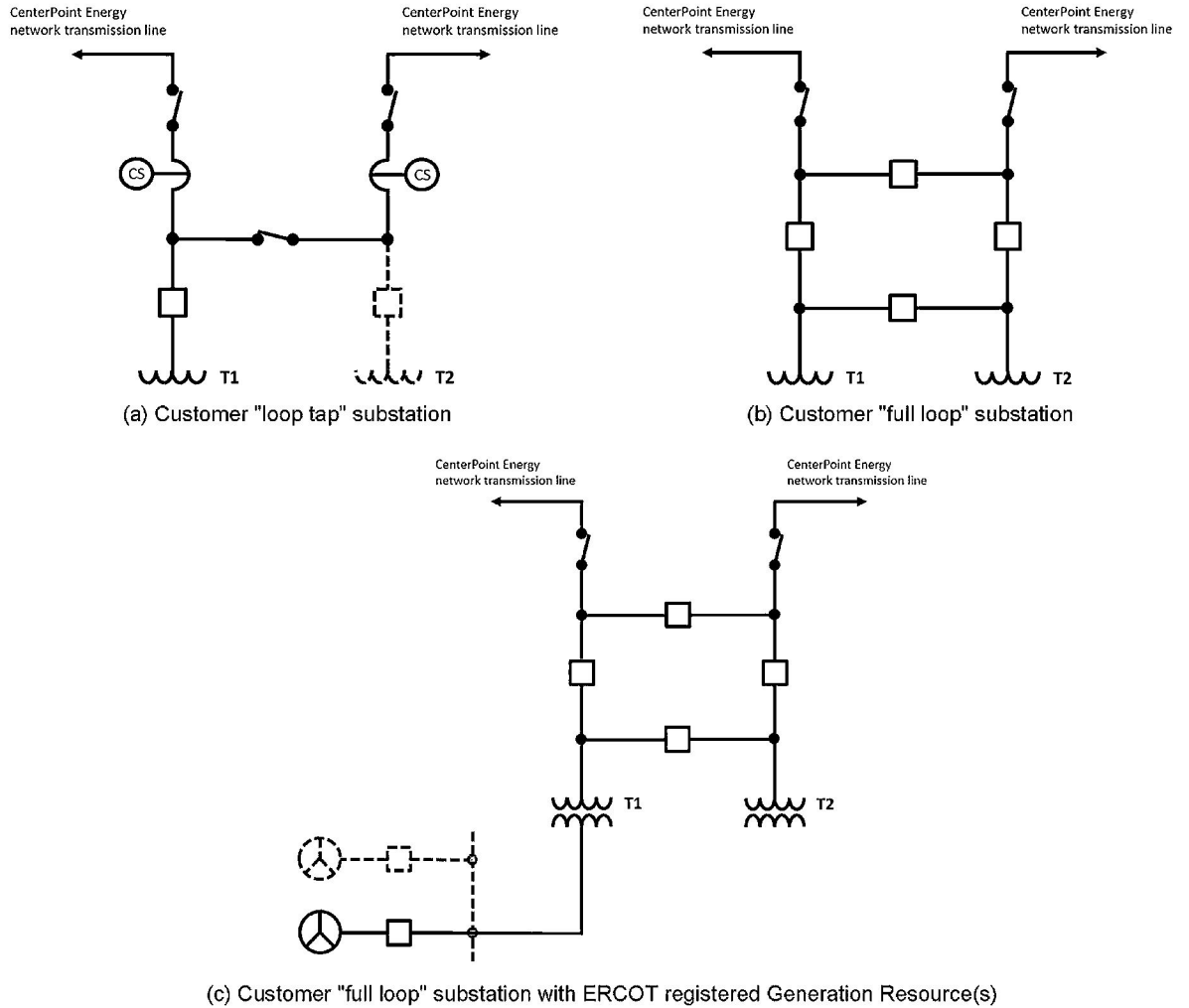

Figure 3 – Typical customer-owned load transmission substation interconnection arrangements

CenterPoint Energy Houston Electric		
WRITTEN	12/30/03	C.W. Mogannam
CHECKED	12/30/03	R.M. Secrest
APROVED	12/30/03	M.W. Furnish
Page 7 of 15		
SPC	007	400 02

**3.2. General SCADA requirements**

- 3.2.1. Installation of a CNP-owned SCADA RTU in customer-owned facilities **is required** for all new customer-owned load transmission substations, including load customer substations with ERCOT registered generation resource(s).
- 3.2.2. Existing customer-owned substations originally connected without SCADA monitoring shall be required to install a new CNP-owned SCADA RTU when there is a significant change in the topology of the substation or as directed by ERCOT. Existing customer-owned substations with obsolete SCADA equipment shall be required to upgrade the SCADA equipment at CNP's discretion.
- 3.2.3. CNP shall specify and install SCADA equipment as required. The CNP SCADA RTU shall be in a locked cabinet installed in the customer substation control cubicle.
  - 3.2.3.1. The customer shall provide an electrical relaying and metering one-line diagram of the proposed customer-owned substation for review by CNP.
  - 3.2.3.2. The customer shall provide interface equipment such as SCADA electronic panel meters, transducers, status and alarm contacts, cabling, terminal blocks, and conduit to provide the data required in this specification.
  - 3.2.3.3. The customer shall install and maintain voice communication equipment in the customer substation control cubicle.
  - 3.2.3.4. CNP shall specify, install, and maintain a locked Substation Communications cabinet(s) inside the customer control cubicle for SCADA, metering, and other CNP communications needs.
- 3.2.4. The CNP SCADA RTU shall gather data from substation Intelligent Electronic Devices (IEDs) such as microprocessor relays or SCADA electronic meters.
  - 3.2.4.1. IEDs that CNP provides and maintains settings for (i.e. protective relays for CNP transmission network) **are not allowed** to be monitored directly by the customer. The data from these IEDs can be provided to the customer from a serial port on the CNP SCADA RTU.
  - 3.2.4.2. The customer can connect directly to other IEDs such as SCADA electronic meters and microprocessor relays that CNP does not provide and maintain settings for.
- 3.2.5. Most data in the CNP SCADA RTU as described in Section 3.3 below, except CNP transmission network power flow data, shall be available to share with the customer upon customer's request, via a designated DNP3 serial port of the CNP SCADA RTU.
- 3.2.6. Real-time telemetry data from ERCOT-Polled Settlement (BPS) meters and revenue meters shall not be shared with the customer through the CNP SCADA RTU or through direct connection(s).
- 3.2.7. All applicable data listed in this section shall be provided continuously to CNP RTU, whether through a CNP-owned RTU, through CNP-connected communication ports, or customer-owned SCADA RTU ports. CNP's periodicity for scanning the data from established communication ports and SCADA RTU ports shall be set in accordance with the ERCOT requirements.
- 3.2.8. Load customers with ERCOT registered generation resource(s) shall provide plant data to ERCOT according to ERCOT requirements. CNP is not responsible for providing the customer plant data to ERCOT.
- 3.2.9. All equipment and work covered by this specification shall be designed, constructed, and tested in accordance with the latest revisions or editions of industry requirements in effect at the time of fabrication. Industry requirements include the applicable codes, standards, specifications, regulations, tests, and procedures of all federal, state, and local laws, and include (but are not limited to) the following:
  - 3.2.9.1. American National Standards Institute (ANSI)
  - 3.2.9.2. IEEE formerly the Institute of Electrical and Electronics Engineers, Inc.
  - 3.2.9.3. National Electrical Manufacturers Association (NEMA)

CenterPoint Energy Houston Electric		
WRITTEN	12/30/03	C.W. McGannem
CHECKED	12/30/03	R.M. Secrest
APPROVED	12/30/03	M.W. Furnish
Page 8 of 15		
SPC	007	400 02

- 3.2.9.4. Occupational Safety and Health Administration (OSHA)
- 3.2.9.5. Federal Communications Commission (FCC)
- 3.2.10. In the event of conflicting requirements, the order of precedence shall be this specification, other referenced CNP specifications, and the standards referenced in Section 3.2.9 above.
- 3.2.11. All equipment, engineering, and installation shall be furnished by the customer unless otherwise noted in this specification or separate agreements.
- 3.2.12. This specification covers the requirements between the customer and CenterPoint Energy and is not meant to cover any additional requirements that the customer may have with ERCOT.

**3.3. The CNP SCADA RTU subsystems**

The CNP SCADA RTU is composed of three subsystems: analog, status, and control.

**3.3.1. Analog subsystem**

Analog data is typically gathered from IEDs and/or transducers. If transducers are used, CNP shall determine the transducer electrical requirements. See table 1 in the Appendix for acceptable transducer models. Meter test switches are required for the transducer current and voltage connections.

The following analog data shall be monitored by the CNP SCADA RTU:

- 3.3.1.1. Kilovolts for transmission level voltages (AØ scaled as a line-to-line value).
- 3.3.1.2. Megawatts and megavars for each line position (3Ø).
- 3.3.1.3. Megawatts and megavars for each substation load and/or substation transmission level transformer (3Ø).
- 3.3.1.4. Net megavars for transmission reactive support equipment (3Ø).

**3.3.2. Status subsystem**

The status subsystem of the CNP SCADA RTU shall consist of the following:

- 3.3.2.1. Status of selected transmission voltage circuit breakers or other devices directly affecting the CNP electrical system, as determined by CNP RTO. Status shall be derived from either an isolated auxiliary "a" contact in the breaker or monitoring a trip coil of the breaker. Refer to Figure 4 in the Appendix for Breaker Status Connection using trip coil monitoring method.
- 3.3.2.2. Indication of low voltage and battery charger failure is required for the 130 VDC battery system(s). Typical charger alarms include the following: low voltage, high voltage, loss of AC input, and loss of charger. All these indications shall be combined so that an occurrence of any one of these shall cause a single battery alarm (normally open contact) to the CNP SCADA RTU.
- 3.3.2.3. SCADA Close Inhibit (SCI) indication is required of breakers controlled by SCADA whenever a lockout relay can inhibit breaker closure by SCADA. A dry, normally-open contact from that relay shall be supplied for SCI indication. Indication contacts from all lockout relays shall be wired in parallel for a single indication in the SCADA cabinet. See Figure 4.
- 3.3.2.4. Indication of Carrier Tester (CAR) or Pilot Wire/Fiber Optic (PIL) relaying failure where applicable.
- 3.3.2.5. Indication for the loss of a potential to a line relay (PT1) that could cause a mis-operation of the zone. This alarm is typically generated by a contact from the line relay. Indications from separate relays shall be combined for a single alarm.

CenterPoint Energy Houston Electric		
WRITTEN	12/30/03	C.W. McGannem
CHECKED	12/30/03	R.M. Secrest
APPROVED	12/30/03	M.W. Furnish
Page 9 of 15		
	SPC	007 400 02

- 3.3.2.6. Indication of a failed self-check diagnostic of a microprocessor-based relay, designated as Relay CPU Fail (RCPU). This alarm is typically generated by a contact from the line relay. Indications from separate relays shall be combined for a single alarm.
- 3.3.2.7. Cabinet Alarm (CABS) for the CNP SCADA RTU and the CNP Communications Cabinets. This alarm is generated when the cabinet door is opened.

3.3.3. Control subsystem

The control subsystem of the SCADA RTU shall consist of the following:

- 3.3.3.1. CNP shall have remote control of all transmission (69kV, 138kV, 345kV) circuit breakers that directly affect the CNP transmission system as determined by CNP RTO. Dual remote control (control of a breaker by both the customer's control system and CNP RTO) is not permitted. Figure 4 in the Appendix illustrates how SCADA control interfaces with a typical breaker control scheme.
- 3.3.3.2. CNP shall have remote control, automatic carrier removal (ATCR), of each pilot relaying scheme. A control contact from the SCADA RTU shall be installed in each pilot circuit. See Figure 4 for typical carrier control circuit.
- 3.3.4. For load customer substations with ERCOT registered generation resources, additional data below shall be required by CNP from the customer's Plant. This data is typically obtained via communication from the Plant RTU/DCS to the CNP SCADA RTU.
  - 3.3.4.1. Analog data from Plant
    - 3.3.4.1.1. Kilovolts for each low-side generator or collector bus ( $\Delta\emptyset$  scaled as a line-to-line value).
    - 3.3.4.1.2. Net megawatts and megavars for each generator feeder ( $3\emptyset$ ).
    - 3.3.4.1.3. Net megavars for the reactive support equipment ( $3\emptyset$ ).
    - 3.3.4.1.4. Net megawatts and megavars for the transmission line ( $3\emptyset$ ).
    - 3.3.4.1.5. Frequency at each collector bus.
    - 3.3.4.1.6. Megawatts and megavars for each transformer ( $3\emptyset$ ), either on the high side or the low side.
  - 3.3.4.2. Status data from Plant
    - 3.3.4.2.1. Status of all low-side circuit breakers for feeders and reactive support equipment.
    - 3.3.4.2.2. Status of generator automatic voltage regulator (automatic and manual).

**3.4. CNP SCADA RTU design, layout, and physical criteria**

3.4.1. SCADA RTU designation

The type of SCADA RTU installed by CNP shall depend on the number of controlled breakers.

- 3.4.1.1. For breakered transmission substation configuration such as "full loop", "ring bus", or "breaker-and-a-half", CNP typically installs a free-standing cabinet 24" wide by 18" deep and 72" tall, with front access. Clearance of 30" in front of the door shall be reserved for maintenance access. Substations with more than four transmission breakers may require a larger cabinet(s). Refer to latest customer RTU drawing submitted by CNP at the project kick-off.
- 3.4.1.2. Substations with "loop tap" configuration generally require a smaller, wall-mounted RTU cabinet. The wall-mounted cabinet is 30" wide by 12" deep and 42" tall. Clearance of 30" in front of the door shall be reserved for maintenance access.

3.4.2. Access to the CNP SCADA RTU cabinet shall be controlled by CNP.

3.4.3. Connections to the RTU

The Construction Contractor shall install all interconnections between the CNP

CenterPoint Energy Houston Electric		
WRITTEN	12/30/03	C.W. Mogannam
CHECKED	12/30/03	R.M. Secrest
APPROVED	12/30/03	M.W. Furnish
Page 10 of 15		
SPC	007	400 02

SCADA RTU and the substation panels.

- 3.4.3.1. The customer shall provide a 120 VAC, fifteen (15) amp, dedicated AC power circuit, protected by a fifteen (15) amp circuit breaker, to the SCADA RTU Cabinet for lighting and a convenience outlet.
- 3.4.3.2. The customer shall provide a 130 VDC, fifteen (15) amp, dedicated DC power circuit, protected by a fifteen (15) amp circuit breaker, to the SCADA RTU Cabinet for the main RTU power.
- 3.4.3.3. All cable shields shall be grounded at a location other than the CNP SCADA RTU Cabinet. Cable shields shall be grounded at one end only.

3.4.4. Cabling

The customer shall size and install all conduit or cable troughs in accordance with ANSI/NFPA 70 (National Electrical Code).

- 3.4.4.1. Polyethylene Polyvinylchloride (PEPVC) insulated-shielded 2/C #16 cable with stranded copper conductors shall be used for terminations for all transducer outputs and all RS485 inter-panel connections.
- 3.4.4.2. Breaker controls shall use seven conductor (#12) PEPVC insulated cable with stranded copper conductors for terminations.
- 3.4.4.3. Two conductor (#10 or larger) PEPVC insulated cable with stranded copper conductors shall be used for terminations of the AC and DC power circuit.
- 3.4.4.4. Status and alarms shall be terminated with two conductor (#16) PEPVC insulated cable with stranded copper conductors.
- 3.4.4.5. The customer shall install the necessary conduit or cable management between the SCADA RTU and the relay panels.
- 3.4.4.6. Every breaker with 130 VDC SCADA control circuits shall have breaker coil surge suppression. One 100 [Ω], 11 [W] resistor (Ohmite style 995-10A) and one Zener diode (Motorola type IN3051A) or equivalent shall be used for this suppression. The series combination of the Zener diode and the resistor shall be parallel to each breaker trip and breaker close coil. STATES sliding link terminal blocks shall be installed in the breakers for terminating the resistors and Zener diodes. See Figure 4. CNP shall verify breaker coil surge suppression.

**3.5. Communication lines and telemetry transport**

- 3.5.1. The customer shall provide and maintain a direct-dial telephone landline for voice communications inside the control house cubicle. The phone shall have an extendable cord such that the handset can be stretched to the front of the relay panels and SCADA RTU so they can be viewed and operated by the person using the phone. The telephone landline must continue to operate during a site power failure.
- 3.5.2. CNP shall provide a Telecom transport option for telemetry backhaul and connectivity using one of the following options determined by CNP: CNP microwave, CNP fiber, or leased-circuit.
- 3.5.3. For CNP microwave option:
  - 3.5.3.1. CNP shall provide tower height and wind load specifications to the customer.
  - 3.5.3.2. The customer shall procure, install, own, and maintain the tower.
  - 3.5.3.3. The customer to provide 2" conduit from the microwave pole/tower to Telecom Enclosure as per CNP Telecom Customer Project Plan.
  - 3.5.3.4. CNP shall procure, install, own and maintain the microwave radio and related equipment.

CenterPoint Energy Houston Electric		
WRITTEN	12/30/03	C.W. Mogannam
CHECKED	12/30/03	R.M. Secrest
APPROVED	12/30/03	M.W. Furnish
Page 11 of 15		
SPC	007	400 02

- 3.5.3.5. The customer shall provide a flame retardant coated 4' x 8' sheet of 3/4" plywood for CNP enclosures.
- 3.5.3.6. CNP shall install a communications enclosure on the backboard provided by the customer as shown in CNP Telecom Customer Project Plan, Telecom Board Layout.
- 3.5.3.7. The customer shall install conduits and cables from the communications enclosure to the AC distribution panel, DC distribution panel, ground bus bar, SCADA RTU cabinet, meter can, and the TWS cabinet if there is one. CNP communications equipment requires a dedicated 20A 120VAC power breaker, and a dedicated 20A 130VDC power breaker as shown in CNP Telecom Customer Project Plan, Telecom Board Layout
- 3.5.4. For CNP fiber option:
  - 3.5.4.1. The customer shall provide a path for the fiber to the control cubicle.
  - 3.5.4.2. The path may be either aerial or underground.
  - 3.5.4.3. CNP shall provide site specific underground or aerial specifications to the customer in a Statement of Work (SOW).
  - 3.5.4.4. The customer shall install the underground duct or poles for aerial installation.
  - 3.5.4.5. The customer shall install fiber supplied by CNP. CNP shall own and maintain the fiber.
  - 3.5.4.6. CNP shall terminate the fiber and install fiber distribution panels.
  - 3.5.4.7. The customer shall provide a flame retardant coated 4' x 8' sheet of 3/4" plywood for CNP enclosures.
  - 3.5.4.8. CNP shall install a communications enclosure on the backboard provided by the customer as shown in Telecom Customer Project Plan, Telecom Board Layout.
  - 3.5.4.9. The customer shall install conduits and cables from the communications enclosure to the AC distribution panel, DC distribution panel, ground bus bar, SCADA RTU cabinet, meter can, and the TWS cabinet if there is one. CNP communications equipment requires a dedicated 20A 120VAC power breaker, and a dedicated 20A 130VDC power breaker as shown in CNP Telecom Customer Project Plan, Telecom Board Layout.
- 3.5.5. For leased circuit option:
  - 3.5.5.1. The customer shall provide a flame retardant coated 4' x 4' sheet of 3/4" plywood space for the Telco demark inside the control cubicle.
  - 3.5.5.2. The customer shall provide a flame retardant coated 4' x 8' sheet of 3/4" plywood for CNP enclosures.
  - 3.5.5.3. CNP shall install a Communications enclosure to be mounted on the backboard provided by the customer as shown in CNP Telecom Customer Project Plan, Telecom Board Layout.
  - 3.5.5.4. The customer shall install conduits and cables from the communications enclosure to the AC distribution panel, DC distribution panel, ground bus bar, SCADA RTU cabinet, meter can, and the TWS cabinet if there is one. CNP communications equipment requires a dedicated 20A 120VAC power breaker, and a dedicated 20A 130VDC power breaker as shown in CNP Telecom Customer Project Plan, Telecom Board Layout.
  - 3.5.5.5. The customer shall provide dedicated 15A 130VDC power and grounding to the backboard. See CNP Telecom Customer Project Plan, Third Party Telco Board Design.

**3.6. Calibration and maintenance**

- 3.6.1. After all equipment necessary for remote telemetry has been installed, CNP personnel shall calibrate and verify operation of all equipment installed per this specification.
- 3.6.2. The RTU and transducers installed per this specification shall be maintained by CNP unless otherwise noted in an agreement with the customer. Maintenance shall

CenterPoint Energy Houston Electric		
WRITTEN	12/30/03	C.W. Mogannam
CHECKED	12/30/03	R.M. Secrest
APROVED	12/30/03	M.W. Furnish
Page 12 of 15		
SPC	007	400 02

include accuracy checks, recalibration and replacement/repair of equipment when needed.

3.6.3. CNP shall furnish locks in series with customer locks to permit access to all switchyard gates, substation control cubicle door(s), and disconnect switches.

**3.7. Current transformers and potential transformers**

3.7.1. The current transformers (CTs) and potential transformers (PTs) necessary for telemetry and protection itemized in this specification shall be provided according to CNP specification 007-231-14. If a particular application is not covered by this specification, then CNP shall designate the necessary PT(s) and CT(s) on the substation one-line diagram that the customer submits for comment and approval.

3.7.2. For some substation layouts, a potential rollover circuit shall be needed. If a potential rollover circuit is needed, it shall be designated by CNP on the one-line diagram that the customer submits for comment and approval.

**3.8. Drawing approval**

3.8.1. The Engineering Contractor shall provide electronic and paper copies of all drawings showing equipment connections and structural details of all equipment associated with the installation of the CNP-owned RTU at the customer facility,

3.8.2. Drawings required by this specification include:

- 3.8.2.1. Substation one-line relaying and metering diagrams illustrating the overall telemetry scheme,
- 3.8.2.2. Substation control cubicle layout(s) and floor plan(s),
- 3.8.2.3. Conduit and cable lists,
- 3.8.2.4. Conduit Layout or Plan and Profile,
- 3.8.2.5. RTU manufacturers prints and customer connections,
- 3.8.2.6. AC Schematics for all power and control circuits,
- 3.8.2.7. AC Relaying Schematics (Electrical Three-Line),
- 3.8.2.8. Relay panel layouts,
- 3.8.2.9. Bill of material for items required by this specification,
- 3.8.2.10. Battery charger alarm relay(s) schematics,
- 3.8.2.11. AC & DC Distribution Panels,
- 3.8.2.12. Communication cable and conduit routing through customer facility, and
- 3.8.2.13. Customer Facility Plot Layout.

CenterPoint Energy Houston Electric		
WRITTEN	12/30/03	C.W. Mogannam
CHECKED	12/30/03	R.M. Secrest
APPROVED	12/30/03	M.W. Furnish
Page 13 of 15		
SPC	007	400 02



## APPENDIX

**Table 1: Acceptable transducers and test switches**

DESCRIPTION	MANUFACTURER	MODEL NO.	MONITORING POINTS
VOLTAGE TRANSDUCER	AMETEK SCIENTIFIC COLUMBUS	VT110A4	ONE PER SUBSTATION BUS
TEST SWITCH SINGLE PHASE	DURHAM	2-1022F-03	ONE PER EACH TRANSDUCER
WATT/VAR TRANSDUCER SINGLE PHASE	AMETEK SCIENTIFIC COLUMBUS	XLWV5C5	ONE PER EACH LINE OR LOAD
WATT/VAR TRANSDUCER THREE PHASE	AMETEK SCIENTIFIC COLUMBUS	XLWV342K5A4	ONE PER EACH LINE, GENERATOR OR LOAD
TEST SWITCH THREE PHASE	DURHAM ABB MEGA POWER SYS STATES	2-1058F-00 FS3A171171001NULL CS3A-556-556-162 FMS #293R-330JF-ST	ONE PER EACH TRANSDUCER

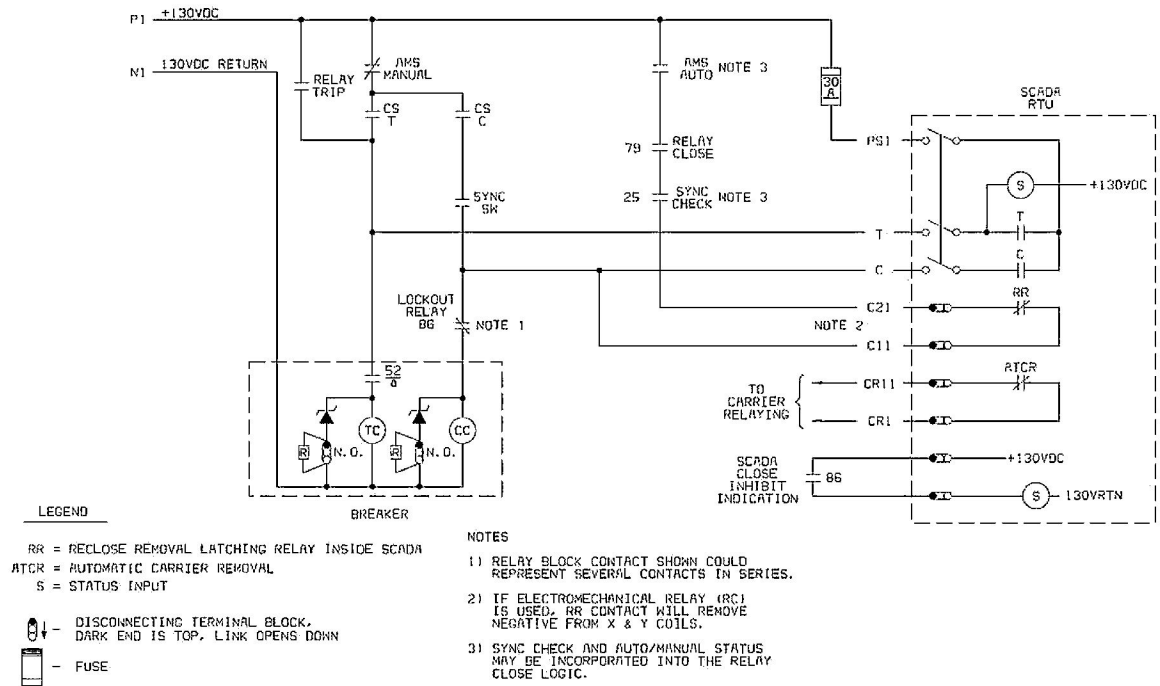

**Figure 4 – Breaker Status Connection using trip coil monitoring method**

CenterPoint Energy Houston Electric			
WRITTEN	12/30/03	C.W. Mogannam	
CHECKED	12/30/03	R.M. Secrest	
APPROVED	12/30/03	M.W. Furnish	
Page 14 of 15			
SPC	007	400	02

**List of abbreviations**

RTU - REMOTE TERMINAL UNIT  
 DCS - DISTRIBUTED CONTROL SYSTEM  
 CR1, CR11 - TYPICAL WIRE NAMES IN CNP CARRIER RELAYING SCHEMES  
 ATCR - AUTOMATIC CARRIER REMOVAL  
 C - CLOSE  
 CS - CONTROL SWITCH  
 25 - SYNCRO-VERIFIER RELAY  
 S - SCADA STATUS INPUT  
 C11, C21 - TYPICAL WIRE NAMES IN CNP RECLOSE REMOVAL SCHEMES  
 NO - NORMALLY OPEN  
 CC - BREAKER CLOSE COIL  
 79 - AUTOMATIC RECLOSING RELAY  
 RR - RECLOSE REMOVAL LATCHING RELAY  
 T - TRIP  
 TC - BREAKER TRIP COIL  
 SSS - SLIDING LINK TERMINAL  
 R - RESISTOR  
 DDD - ZENER DIODE  
 AMS - AUTOMATIC / MANUAL THROWOVER SWITCH (SHOWN IN MANUAL MODE)

CenterPoint Energy Houston Electric		
WRITTEN	12/30/03	C.W. Mogannam
CHECKED	12/30/03	R.M. Secrest
APPROVED	12/30/03	M.W. Furnish
Page 15 of 15		
	SPC	007 400 02

## **Exhibit “H” Drawings**

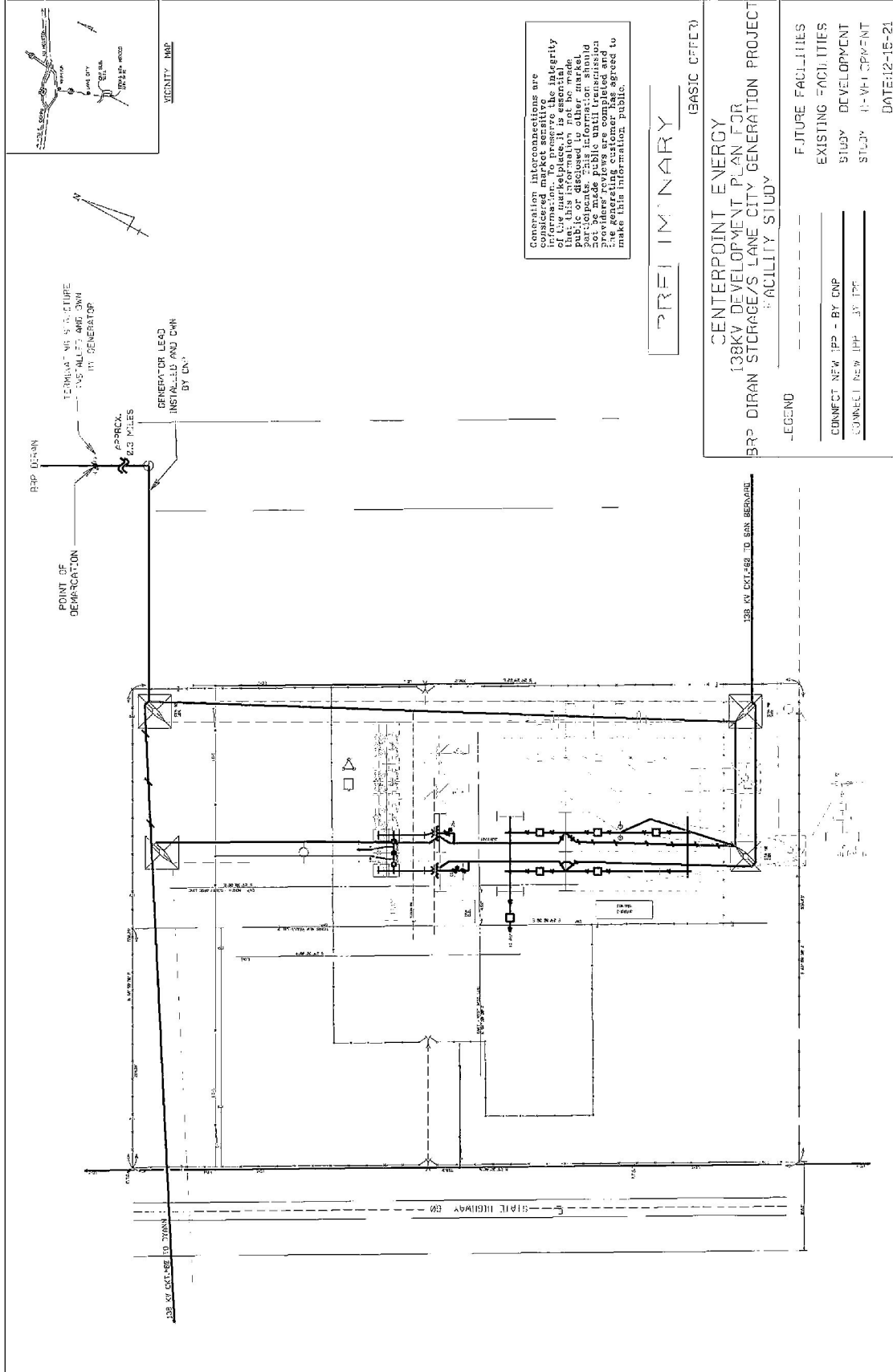

Generation interconnections are considered market sensitive information. The integrity of the marketplace is essential that this information not be made public until transmission participants have agreed to make this information public.

**PRELIMINARY**  
(BASIC OFFER)

**CENTERPOINT ENERGY**  
138KV DEVELOPMENT PLAN FOR  
BRP DIRAN STORAGE/LANE CITY GENERATION PROJECT  
FACILITY STUDY

LEGEND

---	FUTURE FACILITIES
---	EXISTING FACILITIES
---	STUDY DEVELOPMENT
---	STUDY DEVELOPMENT

DATE: 12-18-24

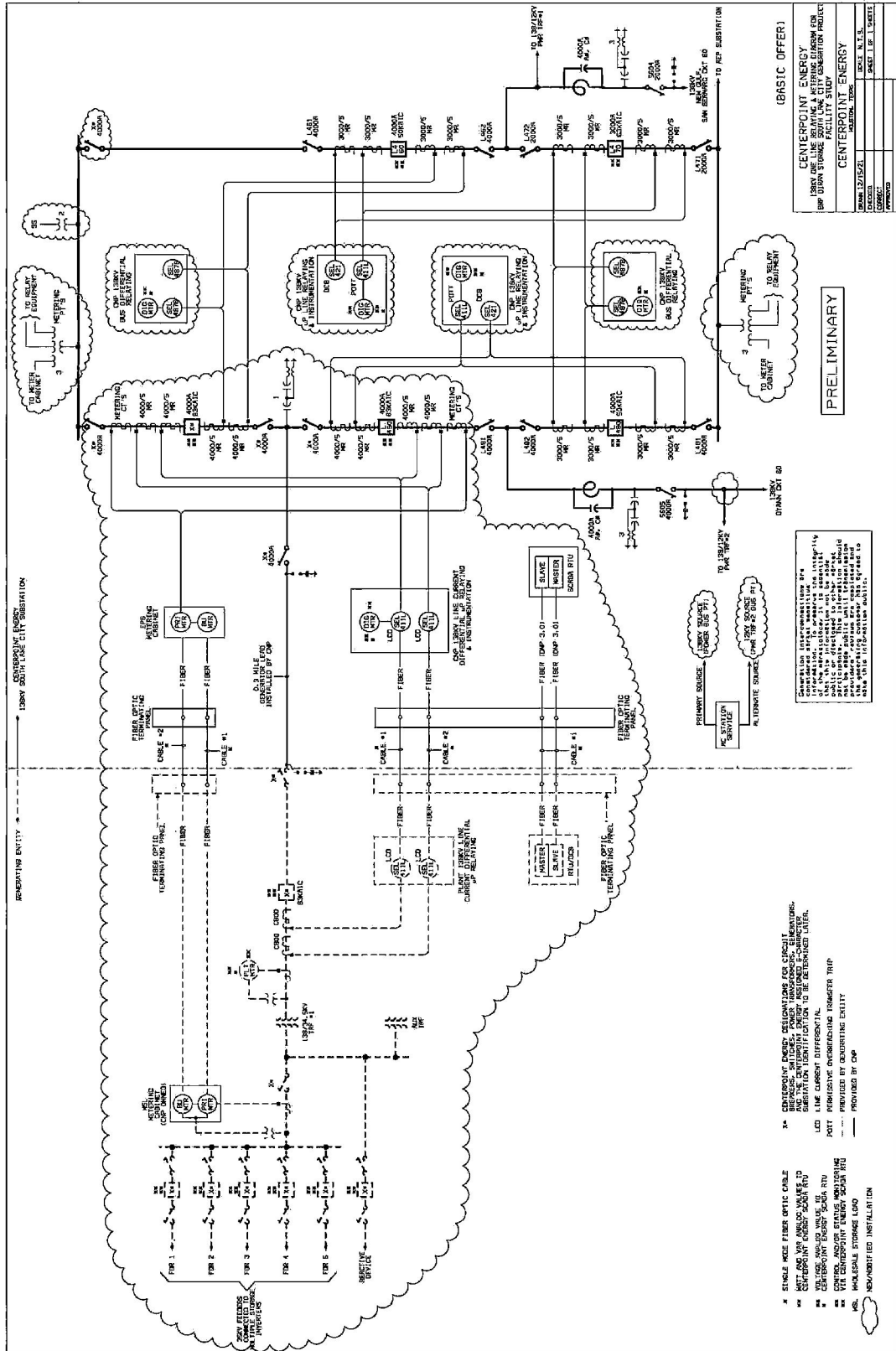

**Exhibit “I”**  
**Specification for Customer-Owned 138 kV Substation Design**

**SPECIFICATION FOR CUSTOMER-OWNED  
SUBSTATION DESIGN**



**ELECTRIC ENGINEERING DEPARTMENT  
P.O. BOX 1700 HOUSTON, TEXAS 77251**

**SPECIFICATION  
FOR  
CUSTOMER-OWNED 138 kV SUBSTATION DESIGN**



**ELECTRIC ENGINEERING DEPARTMENT  
P.O. BOX 1700 HOUSTON, TEXAS 77251**

**REFERENCE DRAWINGS:** Latest revision of  
 CenterPoint Energy 004-241-04, Customer-Owned Substation Line Termination Standard  
 CenterPoint Energy 171-190-06, Design Criteria 138 kV Standard Instrument Transformer Stand, Sh. 1  
 CenterPoint Energy 171-190-06, Design Criteria 138 kV Standard Instrument Transformer Stand, Sh. 2  
 CenterPoint Energy 581-500-01, 138 kV Potential Transformer Schematic and Wiring Diagram

**REFERENCE DOCUMENT:** Latest revision of  
 CenterPoint Energy Transmission & Substation Outage and Clearance Coordination Procedures

**REFERENCE SPECIFICATIONS:** Latest revision of  
 CenterPoint Energy 007-400-02, Specification for Remote Telemetry of a Customer-Owned Facility

**REFERENCE STANDARDS:** Latest revision of  
 AASHTO/IEEE C57.13  
 AISC, "Manual of Steel Construction" IEEE C2 (NESC)  
 ASCE 10 IEEE 80  
 ASCE 113 IEEE 519  
 ANSI C12.1 IEEE 837  
 ANSI C37.32 IEEE 998  
 IEEE C37.04 IEEE 1119  
 IEEE C57.12.00 IEEE 1453  
 IEEE 142 NEMA CC 1

						CENTERPOINT ENERGY HOUSTON, TX		
NO	DATE	ITEMS REVISED	BY	CH	APP	Page 1 of 46 SPECIFICATION No. 007-2231-14		
20	10/7/2024	Added 345kV Specification	Var	Var	JPB			
19	1/3/2024	Update to VRT in 3.5 and minor edits	Var	Var	PM	WRITTEN	4/9/74	E. C. Reid
18	9/8/2023	Updates to various sections	Var	Var	PM	CHECKED	4/10/74	L. G. Pond
17	9/22/21	Update sections 4 & 11	Var	Var	GAC	APPROVED	7/17/74	C. S. Kayser



## Table of Contents

1. SCOPE .....	3
2. GENERAL.....	3
3. CENTERPOINT ENERGY SYSTEM CHARACTERISTICS .....	4
4. ELECTRICAL DESIGN CRITERIA.....	6
5. STRUCTURAL AND MECHANICAL DESIGN CRITERIA .....	13
6. SITE CRITERIA.....	17
7. HIGH VOLTAGE EQUIPMENT.....	19
8. CONTROL CUBICLE.....	23
9. METERING EQUIPMENT .....	23
10. FUSING AND CONNECTION OF PROTECTION AND CONTROL AND METERING CIRCUITS.....	27
11. PROTECTIVE RELAYING FOR HIGH VOLTAGE (138 KV).....	29
12. REMOTE TELEMETRY.....	34
13. GENERATION.....	34
14. DRAWING AND DOCUMENTATION COMPLIANCE REVIEW AND COMMENTS.....	35
15. EQUIPMENT INSTALLATION.....	38
16. REQUIRED TESTS AND INSPECTIONS.....	39
17. RECOMMENDED TESTS AND INSPECTIONS.....	40
18. REFERENCE DRAWINGS .....	43

							CENTERPOINT ENERGY HOUSTON, TX		
20	10/17/2024	Added 345kV Specification	Var	Var	JPB				
19	1/3/2024	Update to VRT in 3.5 and minor edits	Var	Var	PM	WRITTEN	4/9/74	E. C. Reid	
18	9/8/2023	Updates to various sections	Var	Var	PM	CHECKED	4/10/74	L. G. Pond	
17	9/2/2021	Update sections 4 & 11	Var	Var	GAC	APPROVED	7/17/74	C. S. Kayser	
							Page 2 of 46		
NO	DATE	ITEMS REVISED	BY	CH	APP	SPECIFICATION No. 007-2231-14			

1. **SCOPE**

1.1. This specification covers design criteria for a customer-owned 138 kV substation connected to the CenterPoint Energy Houston Electric, LLC (CenterPoint Energy) 138 kV transmission system. This specification is intended to apply to a new customer-owned substation or expansion of an existing customer-owned substation. However, the information in this specification may be applicable when equipment in an existing customer-owned substation is being replaced or modified.

2. **GENERAL**

2.1. A customer that is approved by CenterPoint Energy to receive service from the CenterPoint Energy 138 kV transmission system is required to provide a substation capable of accepting that service from CenterPoint Energy. The customer-owned substation becomes an integral part of the CenterPoint Energy transmission system network and the Electric Reliability Council of Texas (ERCOT) and, therefore, can have a significant impact on overall system reliability. The customer is obligated to meet present CenterPoint Energy design criteria and modify the customer-owned substation in the future as the CenterPoint Energy transmission system continues to evolve. When deemed necessary by CenterPoint Energy, changes may be needed to conform to industry standards, transmission system characteristics, CenterPoint Energy practices, and technological advances to maintain reliability or meet future reliability requirements.

2.2. All equipment and design shall be in accordance with designated standards of this specification, the American National Standards Institute (ANSI), the Institute of Electrical and Electronic Engineers (IEEE), the American Society of Civil Engineers (ASCE), the American Institute of Steel Construction (AISC), and the National Electrical Manufacturing Association (NEMA). In the event of conflicting requirements, the order of precedence shall be this specification, ANSI, IEEE, ASCE, AISC, and NEMA standards. All electrical clearances shall comply with the latest version of the National Electric Safety Code (NESC).

2.3. This specification is not intended to be totally comprehensive. To ensure the efficient coordination between CenterPoint Energy and the customer during the design and construction of the customer-owned substation, CenterPoint Energy requires that engineering documents be submitted to CenterPoint Energy for review before certain equipment is ordered or construction begins. All items requiring CenterPoint Energy review are listed in Article 14 of this specification and shall be submitted in writing to the designated CenterPoint Energy representative.

2.4. Any deviations from this specification or project drawings reviewed by CenterPoint Energy require written acceptance from CenterPoint Energy.

2.5. All labor and equipment shall be furnished by the customer unless otherwise stated in this specification.

2.6. Unless otherwise stated in this specification:

2.6.1. CenterPoint Energy will provide only functional reviews of completed drawings and schematics.

							CENTERPOINT ENERGY HOUSTON, TX		
20	10/17/2024	Added 345kV Specification	Var	Var	JPB				
19	1/3/2024	Update to VRT in 3.5 and minor edits	Var	Var	PM	WRITTEN	4/9/74	E. C. Reid	
18	9/8/2023	Updates to various sections	Var	Var	PM	CHECKED	4/10/74	L. G. Pond	
17	9/2/2021	Update sections 4 & 11	Var	Var	GAC	APPROVED	7/17/74	C. S. Kayser	
							Page 3 of 46		
NO	DATE	ITEMS REVISED	BY	CH	APP	SPECIFICATION No. 007-2231-14			

- 2.6.2. CenterPoint Energy will not verify, or correct, point-to-point wiring drawings for the customer owned substation.
- 2.6.3. CenterPoint Energy requires specific tests which are to be conducted by the customer to verify the proper operation and coordination of the customer-owned substation protection and control equipment (see Article 16 of this specification).
- 2.7. CenterPoint Energy reserves the right to refuse to energize any customer-owned substation which fails to meet this specification.
- 2.8. The customer will coordinate the energization and operation of their high voltage facilities with CenterPoint Energy's Real Time Operations (RTO) Department per CenterPoint Energy's "Transmission & Substation Outage and Clearance Coordination Procedures" document.
- 2.9. During energization of new or existing equipment, the customer shall not disable a single level, or multiple levels, of protection that results in no protection for an energized element, such as, a transmission line, high voltage bus, or transformers.
  - 2.9.1. The customer shall immediately notify the RTO System Controller (281-894-0491) whenever the customer becomes aware of an energized element that has no protection if the protection cannot be immediately restored.
  - 2.9.2. The customer shall immediately notify the RTO System Controller (281-894-0491) of a protective relay that is not functional (such as a "CPU Failure" alarm) or when a protective relay is found powered down, or out of service (such as not enabled), for an energized element.
- 2.10. As owner of the substation, it is the customer's responsibility to comply with the applicable laws, ordinances, codes, rules, and regulations established by applicable government entities.
- 2.11. Because the customer-owned substation becomes an integral part of the CenterPoint Energy transmission system network, CenterPoint Energy requires access to the customer-owned substation and CenterPoint Energy right-of-ways 7 days-a-week, 24 hours-a-day, 365 days-a-year. Site access, site operating procedures and road access to the customer-owned substation by CenterPoint Energy personnel should be considered when determining the substation location.
- 2.12. When terminal blocks and other connections permit, ring tongue lugs shall be used instead of spade or stab-on lugs.

**3. CENTERPOINT ENERGY SYSTEM CHARACTERISTICS**

- 3.1. CenterPoint Energy's phase rotation is designated C-B-A counter-clockwise and the customer shall phase equipment accordingly. Connection of the customer's H1-H2-H3 power transformer leads to CenterPoint Energy's C-B-A, B-A-C or A-C-B phases, respectively, is recommended.
- 3.2. The CenterPoint Energy's system operating voltage is 138kV (L-L)/79.7kV (L-G) +/- 5% for continuous operation and 138kV (L-L)/79.7kV (L-G) +5%/-8% for emergency conditions. Actual steady-state operational voltage varies around the CenterPoint Energy transmission system network.

							CENTERPOINT ENERGY HOUSTON, TX		
20	10/17/2024	Added 345kV Specification	Var	Var	JPB				
19	1/3/2024	Update to VRT in 3.5 and minor edits	Var	Var	PM	WRITTEN	4/9/74	E. C. Reid	
18	9/8/2023	Updates to various sections	Var	Var	PM	CHECKED	4/10/74	L. G. Pond	
17	9/2/2021	Update sections 4 & 11	Var	Var	GAC	APPROVED	7/17/74	C. S. Kayser	
							Page 4 of 46		
NO	DATE	ITEMS REVISED	BY	CH	APP	SPECIFICATION No. 007-2231-14			

but facilities with a means to regulate the 138 kV transmission system are typically used to control the voltage to be no more than approximately 142 kV (L-L)/82 kV (L-G) to provide a margin from the maximum 145kV (L-L)/83.7 kV (L-G). Dynamic conditions may be encountered which result in voltage exceeding this range. At a minimum, customer is required to design 138kV substation facilities that are rated for the emergency operating voltage range stated above. For the purpose of the design and rating of the substation and equipment, it shall be assumed that the maximum continuous negative sequence component of the voltage at the 138 kV bus is 2% of the positive sequence voltage. See Sub-Articles 3.4, 3.5, 4.9 and 7.1.4 of this specification for additional relevant information,

- 3.3. Only instrument transformers, surge arresters, station service voltage transformers, generator step-up transformers for generators without co-located non-auxiliary load, and autotransformers are allowed to be connected phase-to-ground on their 138 kV primary terminals.
- 3.4. As the independent system operator (ISO) for the ERCOT Region, ERCOT is responsible for maintaining frequency, which is nominally 60 Hz. Refer to ERCOT (www.ercot.com) Nodal Operating Guides and Protocols for information regarding frequency regulation.
- 3.5. CenterPoint Energy suggests the customer at a minimum utilize the "voltage ride-through" design criteria below when designing and selecting process and control equipment. (Note: This design criteria do not supersede any regulatory voltage ride-through requirements).
  - 3.5.1. When the point of interconnection bus voltage is below 0.5 pu, the minimum ride-through time is 0.15 seconds.
  - 3.5.2. When the point of interconnection bus voltage is at or above 0.5 pu, the minimum ride-through time is 0.2 seconds.
- 3.6. Multiple-shot, staggered, voltage-supervised, automatic reclosing is utilized on the CenterPoint Energy transmission system. The first automatic reclosing attempt for a CenterPoint Energy transmission line typically occurs approximately one second after initial trip. The number of automatic reclosing attempts varies, but the total duration of the automatic reclosing sequence is typically one minute. The customer shall coordinate operation and protection of electric motors, computers and other equipment accordingly.

							CENTERPOINT ENERGY HOUSTON, TX		
20	10/17/2024	Added 345kV Specification	Var	Var	JPB				
19	1/3/2024	Update to VRT in 3.5 and minor edits	Var	Var	PM	WRITTEN	4/9/74	E. C. Reid	
18	9/8/2023	Updates to various sections	Var	Var	PM	CHECKED	4/10/74	L. G. Pond	
17	9/2/2021	Update sections 4 & 11	Var	Var	GAC	APPROVED	7/17/74	C. S. Kayser	
							Page 5 of 46		
NO	DATE	ITEMS REVISED	BY	CH	APP	SPECIFICATION No. 007-2231-14			

4. ELECTRICAL DESIGN CRITERIA

4.1. The minimum acceptable electrical design characteristics for 138 kV facilities and equipment are listed below:

Transformer winding impulse level	550 kV BIL.
Bus and switch insulators, and apparatus bushings (i.e. circuit breaker bushings, transformer bushings, coupling capacitors, capacitive voltage transformers (CVT), current transformers (CT), potential transformers (PT), surge arresters etc.)	650 kV BIL.
Bus and switch insulators leakage distance	132 in. leakage distance (equivalent to extra creep 650 kV BIL. or 750 kV BIL.). Additionally, insulators may require 'coating' in some areas of the system to minimize the likelihood of flashover.
Apparatus bushing leakage distance (circuit breaker bushings, transformer bushings, CVT, CT, PT, surge arresters etc.)	92 in. creep (equivalent to 650 kV BIL. – light contamination levels). Additionally, apparatus bushings may require 'coating' in some areas of the system to minimize the likelihood of flashover.
Phase-to-ground clearance	52 in. (metal to metal)
Phase-to-phase bus spacing (including vertical spacing at crossover point of high and low bus)	63 in. (metal to metal)
Phase-to-phase horizontal spacing at incoming line dead-end structure	144 in. (center line to center line, regardless of the line angle)

4.2. An air insulated customer-owned substation configured in a 'ring bus', 'double-breaker, double-bus' or 'breaker-and-a-half' arrangement equipped with transmission line protective relaying ("full loop") or an air insulated customer-owned substation configured in a 'loop line tap' arrangement without transmission line protective relaying ("loop tap") are allowed by CenterPoint Energy (see Figure 2 through Figure 7). "Ring bus" configurations with more than six breakers shall not be considered.

4.3. Customer-owned substations with aggregated load equal to or greater than 75 MW shall be configured as "full loop". Customers shall convert any existing substation to "full loop" if any future load addition increases aggregate load to 75MW or more.

4.4. Based on the customer-owned substation configuration, equipment in the substation that could be subjected to transmission line load flow current (circuit breakers and disconnect switches, bus work, conductors or any series-connected, current carrying devices, such as, free-standing current transformers, protective relays, instrumentation, or hardware within the ring bus or transmission line breaker-and-a-half bay) and incoming transmission line positions (transmission line disconnect

							CENTERPOINT ENERGY HOUSTON, TX		
20	10/17/2024	Added 345kV Specification	Var	Var	JPB				
19	1/3/2024	Update to VRT in 3.5 and minor edits	Var	Var	PM	WRITTEN	4/9/74	E. C. Reid	
18	9/8/2023	Updates to various sections	Var	Var	PM	CHECKED	4/10/74	L. G. Pond	
17	9/2/2021	Update sections 4 & 11	Var	Var	GAC	APPROVED	7/17/74	C. S. Kayser	
							Page 6 of 46		
NO	DATE	ITEMS REVISED	BY	CH	APP	SPECIFICATION No. 007-2231-14			

switches, line traps, etc.) shall have a minimum continuous current rating of 4000 A and shall have an overload capability of 110 percent of rated current for 2 hours, unless otherwise specified by CenterPoint Energy. The equipment in the customer-owned substation that is not subjected to transmission line load flow current is not required to be 4000 A minimum. However, operational scenarios associated with certain equipment outages could exist that would result in transmission line load current flowing on customer internal lines or buses (customer site internal 'loop line' or customer site internal 'loop bus') and potentially overload the customer's equipment if it is rated less than 4000 A. Therefore, CenterPoint Energy suggests that any customer site internal 'loop line' and customer site internal 'loop bus' (except customer site internal 'radial' line or customer transformer bus connections) be 4000 A minimum (see Figure 2 through Figure 7). For customer-owned substations connecting to four or more CenterPoint Energy 138 kV transmission lines, contact CenterPoint Energy for the required equipment rating.

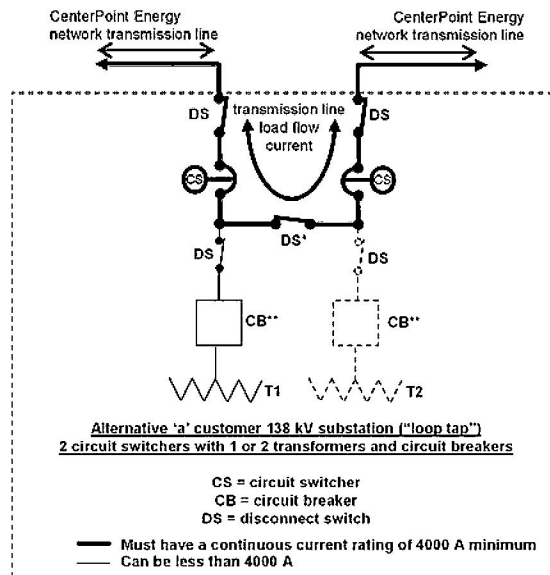

All disconnect switches only have arcing horns. Circuit switchers are required to be installed in this configuration. The circuit switchers are used for manual switching of the network transmission line sections. If two transformers are installed then this disconnect switch is installed and is normally closed.  
 \*\* For substation arranged for future "full loop" service, the 138 kV circuit breakers that will be in the substation "loop" shall have a continuous current rating of 4,000 A (see figures 3 to 7)

Figure 2

						CENTERPOINT ENERGY HOUSTON, TX		
20	10/17/2024	Added 345kV Specification	Var	Var	JPB			
19	1/3/2024	Update to VRT in 3.5 and minor edits	Var	Var	PM	WRITTEN	4/9/74	E. C. Reid
18	9/8/2023	Updates to various sections	Var	Var	PM	CHECKED	4/10/74	L. G. Pond
17	9/2/2021	Update sections 4 & 11	Var	Var	GAC	APPROVED	7/17/74	C. S. Kayser
						Page 7 of 46		
NO	DATE	ITEMS REVISED	BY	CH	APP	SPECIFICATION No. 007-2231-14		

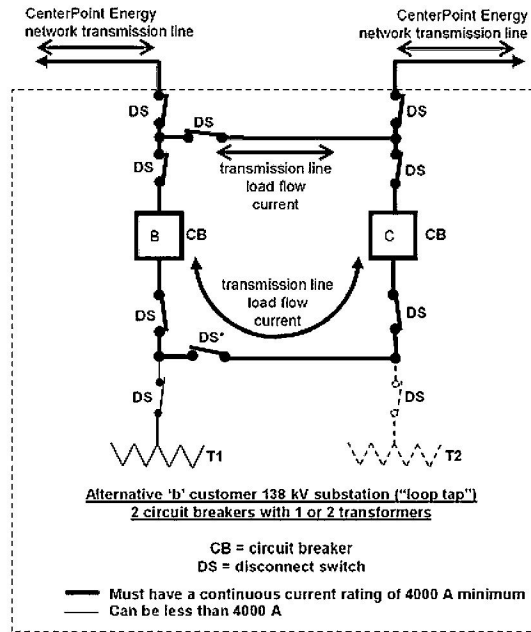

All disconnect switches only have arcing horns. Circuit breakers are not used for manual switching of the network transmission line sections in this configuration. The circuit breakers are used for manual switching of the network transmission line sections.  
\* If two transformers are installed then this disconnect switch is installed and is 'normally open'.

Figure 3

						CENTERPOINT ENERGY HOUSTON, TX		
20	10/17/2024	Added 345kV Specification	Var	Var	JPB			
19	1/3/2024	Update to VRT in 3.5 and minor edits	Var	Var	PM	WRITTEN	4/9/74	E. C. Reid
18	9/8/2023	Updates to various sections	Var	Var	PM	CHECKED	4/10/74	L. G. Pond
17	9/2/2021	Update sections 4 & 11	Var	Var	GAC	APPROVED	7/17/74	C. S. Kayser
						Page 8 of 46		
NO	DATE	ITEMS REVISED	BY	CH	APP	SPECIFICATION No. 007-2231-14		

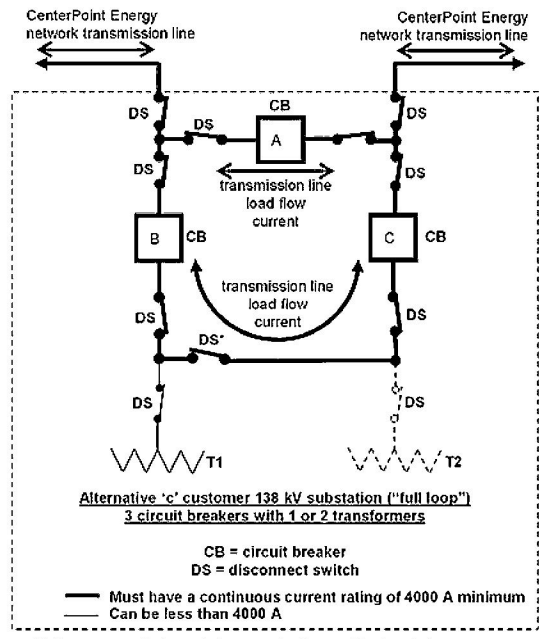

All disconnect switches only have arcing horns. Circuit switchers are not used for manual switching of the network transmission line sections in this configuration. The circuit breakers are used for manual switching of the network transmission line sections.

\* If two transformers are installed then this DS is 'normally open' or 'normally closed' depending on customer operating preference.

**Figure 4**

						CENTERPOINT ENERGY HOUSTON, TX		
20	10/17/2024	Added 345kV Specification	Var	Var	JPB			
19	1/3/2024	Update to VRT in 3.5 and minor edits	Var	Var	PM	WRITTEN	4/9/74	E. C. Reid
18	9/8/2023	Updates to various sections	Var	Var	PM	CHECKED	4/10/74	L. G. Pond
17	9/2/2021	Update sections 4 & 11	Var	Var	GAC	APPROVED	7/17/74	C. S. Kayser
						Page 9 of 46		
NO	DATE	ITEMS REVISED	BY	CH	APP	SPECIFICATION No. 007-2231-14		



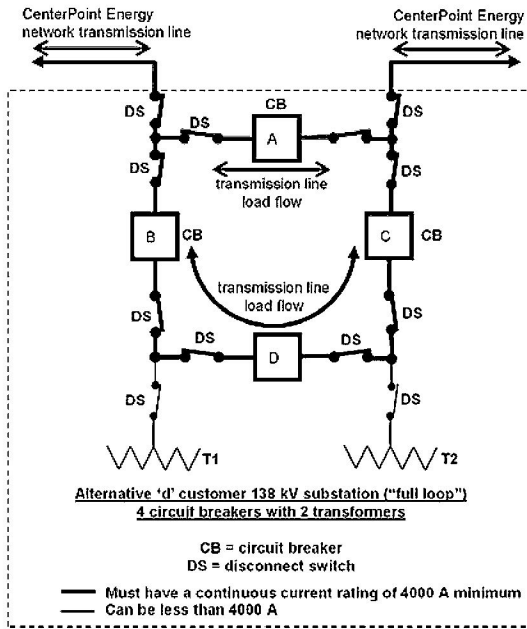

All disconnect switches only have arcing horns. Circuit switchers are not used for manual switching of the network transmission line sections in this configuration. The circuit breakers are used for manual switching of the network transmission line sections.

Figure 5

						CENTERPOINT ENERGY HOUSTON, TX		
20	10/17/2024	Added 345kV Specification	Var	Var	JPB			
19	1/3/2024	Update to VRT in 3.5 and minor edits	Var	Var	PM	WRITTEN	4/9/74	E. C. Reid
18	9/8/2023	Updates to various sections	Var	Var	PM	CHECKED	4/10/74	L. G. Pond
17	9/2/2021	Update sections 4 & 11	Var	Var	GAC	APPROVED	7/17/74	C. S. Kayser
						Page 10 of 46		
NO	DATE	ITEMS REVISED	BY	CH	APP	SPECIFICATION No. 007-2231-14		

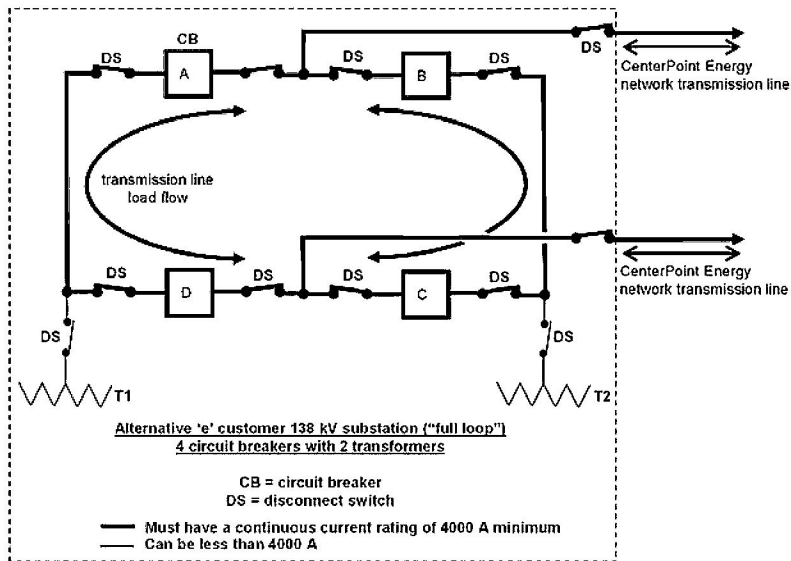

All disconnect switches only have arcing horns. Circuit switchers' are not used for manual switching of the network transmission line sections in this configuration. The circuit breakers are used for manual switching of the network transmission line sections.

Figure 6

						CENTERPOINT ENERGY HOUSTON, TX		
20	10/17/2024	Added 345kV Specification	Var	Var	JPB			
19	1/3/2024	Update to VRT in 3.5 and minor edits	Var	Var	PM	WRITTEN	4/9/74	E. C. Reid
18	9/8/2023	Updates to various sections	Var	Var	PM	CHECKED	4/10/74	L. G. Pond
17	9/2/2021	Update sections 4 & 11	Var	Var	GAC	APPROVED	7/17/74	C. S. Kayser
						Page 11 of 46		
NO	DATE	ITEMS REVISED	BY	CH	APP	SPECIFICATION No. 007-2231-14		

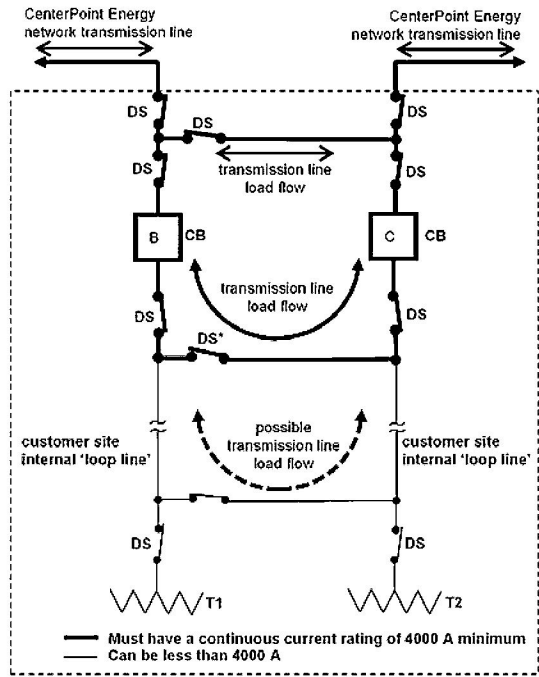

Any customer connection from the "full loop" substation or "loop tap" substation to the customer's transformers, customer buses, or customer lines (i.e. customer plant internal 'loop lines', etc.) are not required to be 4000 A minimum. However, operational scenarios after a scheduled outage of equipment in a customer substation could exist that would result in transmission line load current flowing on customer site internal lines or buses (customer site internal 'loop line' or 'loop bus') and potentially overload the customer's equipment if it is rated less than 4000 A. Therefore, CenterPoint Energy suggests that any customer site internal 'loop line' and customer site internal 'loop bus' (except customer site internal 'radial' line or customer transformer bus connection) be 4000 A minimum.

Figure 7

- 4.5. The 138 kV customer-owned substation shall be designed for a short circuit current of 63 kA rms symmetrical, with X/R ratio of 17, unless otherwise specified by CenterPoint Energy.
- 4.6. 138 kV customer-owned substations which are connected directly into or located within 2 miles electric distance of a CenterPoint Energy 138 kV substation that is designed for a short circuit current of 80 kA rms symmetrical, must be designed to the same short circuit current of 80 kA rms symmetrical, with X/R ratio of 17, unless otherwise explicitly specified by CenterPoint Energy.

						CENTERPOINT ENERGY HOUSTON, TX		
20	10/17/2024	Added 345kV Specification	Var	Var	JPB			
19	1/3/2024	Update to VRT in 3.5 and minor edits	Var	Var	PM	WRITTEN	4/9/74	E. C. Reid
18	9/8/2023	Updates to various sections	Var	Var	PM	CHECKED	4/10/74	L. G. Pond
17	9/2/2021	Update sections 4 & 11	Var	Var	GAC	APPROVED	7/17/74	C. S. Kayser
						Page 12 of 46		
NO	DATE	ITEMS REVISED	BY	CH	APP	SPECIFICATION No. 007-2231-14		

- 4.7. The application of key interlock systems is not permitted on customer-owned substation 138 kV equipment.
- 4.8. The customer's connected load, generation and equipment shall be designed and operated to adhere to the recommended harmonic limits of IEEE 519 and limits of voltage fluctuations and associated light flicker of IEEE 1455.
- 4.9. The customer shall not, without CenterPoint Energy's consent, connect or operate equipment that produces voltage fluctuations, interference or distorted wave forms that adversely affect service to other customers or that may be detrimental to the CenterPoint Energy transmission system. Such equipment includes, but is not limited to, motors, arc furnaces, capacitor banks, etc. The customer is obligated to provide load and equipment information (i.e., load magnitude, peak load, load profile, amount of self-serve generation, load characteristics, motor starting data, load increase) for CenterPoint Energy interconnection study and development of interconnection requirements. CenterPoint Energy may require the installation, on customer's side of the meter, of suitable apparatus or other equipment designed specifically to reasonably limit such adverse effects.
- 4.10. The customer-owned substation ground mat shall be designed for a short circuit current of 63 kA rms symmetrical with X/R ratio of 17 and duration of 0.25 seconds and comply with IEEE 80 and IEEE C2 (NESC). Ground mat connections shall comply with IEEE 837, unless otherwise specified by CenterPoint Energy.
- 4.11. 138 kV customer-owned substations which are connected directly into or located within 2 miles electric distance of a CenterPoint Energy substation that is designed for a short circuit current of 80 kA rms symmetrical, shall design the ground mat for a short circuit current of 80 kA rms symmetrical, with X/R ratio of 17 and duration of 0.25 seconds and comply with IEEE 80 and IEEE C2 (NESC). Ground mat connections shall comply with IEEE 837, unless otherwise specified by CenterPoint Energy.
- 4.12. The customer-owned substation direct lightning stroke-shielding design shall comply with IEEE 998.
- 4.13. The customer shall refer to the current CenterPoint Energy tariff for retail delivery service regarding additional information pertaining to load balance, intermittent electrical loads and limitations on adverse effects, equipment sensitive to voltage and wave forms, change in retail customer's electrical load, power factor, and testing of retail customer equipment.

**5. STRUCTURAL AND MECHANICAL DESIGN CRITERIA**

- 5.1. The customer shall provide a complete structural and foundation design package for the dead-end structures (supporting the CenterPoint Energy transmission lines connected to the customer-owned substation) and the instrument transformer stands in accordance with Article 14 of this specification. The design package shall be signed and sealed by a professional engineer registered in Texas and shall include design references/codes, computer analysis, member design, connection design, foundation design, soil report, structural and foundation drawings, and all other information that documents the design of the structure(s). ASCE 113, 2<sup>nd</sup> Edition may be used for guidance in the design of structures inside the customer-owned substation.
- 5.2. CenterPoint Energy transmission structures designated for CenterPoint Energy use shall be used

							CENTERPOINT ENERGY HOUSTON, TX		
20	10/17/2024	Added 345kV Specification	Var	Var	JPB				
19	1/3/2024	Update to VRT in 3.5 and minor edits	Var	Var	PM	WRITTEN	4/9/74	E. C. Reid	
18	9/8/2023	Updates to various sections	Var	Var	PM	CHECKED	4/10/74	L. G. Pond	
17	9/2/2021	Update sections 4 & 11	Var	Var	GAC	APPROVED	7/17/74	C. S. Kayser	
Page 13 of 46									
NO	DATE	ITEMS REVISED	BY	CH	APP	SPECIFICATION No. 007-2231-14			

exclusively by CenterPoint Energy and will not be used to support customer equipment including customer-owned generator leads.

- 5.3. Design shall be based upon loadings realistically combined to cause the most unfavorable effect upon the structure or component. The loads and overloads specified in Sub-Articles 5.4 and 5.5 of this specification must be used. If the AISC LRFD method is used, the structure must have a second order elastic analysis (also called a Geometric Nonlinear Analysis);
- 5.4. Structures shall meet the Strength Requirements of IEEE C2 (NESC), Section 26, for grade B construction.
- 5.5. The minimum acceptable structural design loading criteria shall be the more severe of the following two cases (note the cases incorporate loads up to a 30° horizontal angle):
  - 5.5.1. Case 1 - Ice with Concurrent Wind Loading: Reference specification IEEE C2 (NESC); minimum allowable strength factors per Section 26, Table 261-1; loading requirements per Section 25; Rule 250.B and Table 250-1; and loading components to be applied to the structure shall be according to Figure 8 of this specification. The static wire and phase wire loads shown in Case 1 include the required overload factors. The 9 psf wind on the structure must include a 2.50 overload (22.5 psf) with the appropriate force coefficient ( $C_f$ ) for each structural member.

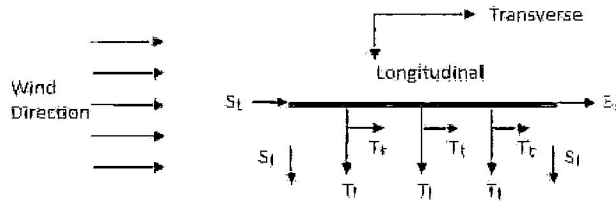

Wind and Ice loads are specified in Section 25 of IEEE C2

Static wire	Phase wire
$S_t = 10.5$ kips/wire longitudinally	$T_t = 23.0$ kips/phase longitudinally
$S_r = 6.7$ kips/wire transversely	$T_t = 14.4$ kips/phase transversely
$S_v = 0.5$ kips/wire vertically	$T_v = 1.5$ kips/phase vertically

CASE 1 - Ice with concurrent Wind Loading - Overhead  
View Static wire and Phase wire loading component  
(The static wire and phase wire loads shown include the required overload factors)

Figure 8

- 5.5.2. Case 2 - Extreme Wind Loading: Reference specification, IEEE C2 (NESC) Section 25, Rule 250.C; minimum allowable strength factors per IEEE C2 (NESC), Section 26, Table 261-1;

						CENTERPOINT ENERGY HOUSTON, TX		
20	10/17/2024	Added 345kV Specification	Var	Var	JPB			
19	1/3/2024	Update to VRT in 3.5 and minor edits	Var	Var	PM	WRITTEN	4/9/74	E. C. Reid
18	9/8/2023	Updates to various sections	Var	Var	PM	CHECKED	4/10/74	L. G. Pond
17	9/2/2021	Update sections 4 & 11	Var	Var	GAC	APPROVED	7/17/74	C. S. Kayser
						Page 14 of 46		
NO	DATE	ITEMS REVISED	BY	CH	APP	SPECIFICATION No. 007-2231-14		

and magnitude and direction of static wire and phase wire loading components to be applied to the structure shall be according to Figure 9 of this specification. The static wire and phase wire loads shown in Case 2 include the required CenterPoint Energy overload factors. The wind on structure loads is applied in the Transverse direction and must include a 1.1 overload factor. CenterPoint Energy will provide the designated Extreme Wind velocity to be used at the site. Structural member shape factors shall be used from ASCE 74.

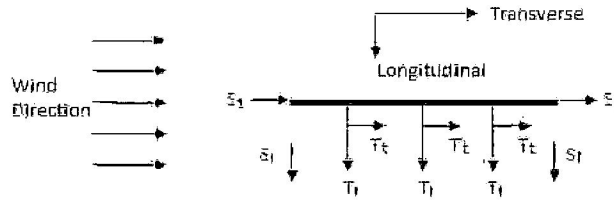

For Case 2 the following shall apply:  
 Basic Wind speed determined from wind map for Exposure Category G,  
 Risk Category I, Design wind pressure equation and coefficients  
 per IEEE C2 (NESC) Rule 250.C in latest version

Static wire	Phase wire
$S_l = 12.0$ kips/wire longitudinally	$T_l = 22.0$ kips/phase longitudinally
$S_t = 5.5$ kips/wire transversely	$T_t = 10.5$ kips/phase transversely
$S_v = 0.5$ kips/wire vertically	$T_v = 1.5$ kips/phase vertically

Case 2 - Extreme Wind Loading – Overhead View  
 Static wire and Phase wire loading component  
 (The static wire and phase wire loads shown include the required overload factors)

Figure 9

5.6. The requirements for dead-end structures are as follows:

- 5.6.1. Customer shall design all attachment points to ensure that sufficient electrical clearance is maintained to the customer's structure ground and equipment. CenterPoint Energy will extend the phase wires to the first item of customer's equipment or bus and will furnish, own and maintain all necessary fittings for terminating the phase wires including the tower fittings, suspension insulators, dead-end clamps and phase wire terminal fittings with NEMA CC 1 standard four-hole terminals (0.5625 in. diameter holes; 1.75 in. centers) for attachment to the first item of equipment or bus in the customer-owned substation. CenterPoint Energy will also furnish stirrup clamps or other similar devices (such as a bar on the NEMA pad that is used with ACSS conductors) on the phase wires as required for connection of surge arresters and potential transformers. Customer will provide a grounding conductor from the customer-owned substation ground mat, up the dead-end structure, to the static wire pull-off plates.

						CENTERPOINT ENERGY HOUSTON, TX		
20	10/17/2024	Added 345 kV Specification	Var	Var	JPB			
19	1/3/2024	Update to VRT in 3.5 and minor edits	Var	Var	PM	WRITTEN	4/9/74	E. C. Reid
18	9/8/2023	Updates to various sections	Var	Var	PM	CHECKED	4/10/74	L. G. Pond
17	9/2/2021	Update sections 4 & 11	Var	Var	GAC	APPROVED	7/17/74	C. S. Kayser
						Page 15 of 46		
NO	DATE	ITEMS REVISED	BY	CH	APP	SPECIFICATION No. 007-2231-14		

CenterPoint Energy will furnish, own and maintain all necessary fittings for terminating the static wire and for connecting the static wire to the customer provided substation ground conductor at the static wire pull-off plates including the tower fittings, dead-end clamps and static wire terminal fittings for attachment to the customer provided substation ground conductor.

- 5.6.2. Customer shall provide pull-off plates for terminating the phase wires and static wires which will accommodate a minimum of 1 in. pin. All pull-off plates must satisfy Equations 4.6-1 and 4.6-2 in ASCE 10. Details for division of ownership shall be in accordance with CenterPoint Energy Drawing 004-241-04 Customer-Owned Substation Line Termination Standard.
- 5.6.3. The height of the dead-end structure's phase wire attachment shall be in accordance with the National Electric Safety Code (IEEE C2) or 40 ft, whichever is greater, unless otherwise specified by CenterPoint Energy. The static wire height at attachment shall be at a sufficient elevation and position to provide a shield angle to the outside phase wires of 30° and 45° between two adjacent static wires (see IEEE 142).
- 5.6.4. CenterPoint Energy will determine if the installation of fiber optic cable is required for transmission line protective relaying and/or control purposes. The fiber optic cable installation will normally be installed underground from the transmission line protective relay requiring fiber optic communication (i.e., relay located in the substation control cubicle) to the base of the first CenterPoint Energy transmission line structure outside the substation. However, should an overhead installation be required, additional loadings will be imposed on the customer's dead-end structure. Additional design information concerning the fiber optic cable will be supplied by CenterPoint Energy when overhead fiber optic cable is to be used. The connection for the fiber optic cable is typically at least 8 feet from the nearest phase wire. If an overhead installation is required and the fiber optic cable cannot be accommodated on the dead-end structure, a single pole must be installed in the customer-owned substation to transition the fiber optic cable from overhead to underground.
- 5.6.5. If multiple dead-end bays are installed that share a middle column or support, the support must be designed to withstand the loads from the adjacent circuits.
- 5.7. When high-side (138 kV) metering is utilized, the customer shall design, provide and install stands for mounting CenterPoint Energy furnished instrument transformers (potential and current transformers). The customer shall also design and build foundations to support the stands and instrument transformers. The designs shall be in accordance with Sub-Articles 5.1- 5.4 of this specification. The extreme wind speed defined in section 5.5.2 shall be used with an appropriate member and equipment shape factor. The instrument transformer parameters to be used for the design of the instrument transformer stand are indicated on CenterPoint Energy drawing 171-190-06. Since the instrument transformer may change in the future, the stand mounting surface for the instrument transformer must be adjustable or use grating to accommodate diverse mounting bolt patterns. If a grating is used for the stand mounting surface for the instrument transformer, washer plates of sufficient size and thickness to load up 4 bars must be used on top and bottom of the grating. Design calculations showing the load transfer from the bolt to the washer plates to the bars to the column must be provided. The customer is responsible for providing the bolts and washer plates. The customer will design a mounting stand and foundation for the hurricane wind speeds and overloads.

							CENTERPOINT ENERGY HOUSTON, TX		
20	10/17/2024	Added 345kV Specification	Var	Var	JPB				
19	1/3/2024	Update to VRT in 3.5 and minor edits	Var	Var	PM	WRITTEN	4/9/74	E. C. Reid	
18	9/8/2023	Updates to various sections	Var	Var	PM	CHECKED	4/10/74	L. G. Pond	
17	9/2/2021	Update sections 4 & 11	Var	Var	GAC	APPROVED	7/17/74	C. S. Kayser	
							Page 16 of 46		
NO	DATE	ITEMS REVISED	BY	CH	APP	SPECIFICATION No. 007-2231-14			

from Sub-Article 5.5.2 of this specification. If the AISC LRFD method is used, the structure must have a second order elastic analysis (also called a Geometric Nonlinear Analysis). The customer shall limit the horizontal deflection of the potential transformer and current transformer stand at the instrument mounting height to the mounting height divided by 100. The wind speed used for the deflection limit shall be 80 mph.

**6. SITE CRITERIA**

- 6.1. Site preparation and plot plan drawings shall be submitted to CenterPoint Energy for comment. Facilities that must be shown on this drawing include: dimensions of the customer-owned substation site, access roadways, space between the customer-owned substation and access roadways, and drainage features such as culverts, ditches and detention facilities (if required). Refer to Sub-Article 14.1.1 of this specification.
- 6.2. The customer shall stake the location of the dead-end structures according to Figure 10. The owner of the substation must submit drawings/documents specific to their substation to CenterPoint Energy in accordance with Article 14 of this specification. The drawings required by Sub-Articles 14.1.1 and 14.1.3 of this specification should show the customer's desired location for CenterPoint Energy phases. CenterPoint Energy will review this information along with the customer-owned substation location and CenterPoint Energy transmission line tower location and determine if the customer's desired location for CenterPoint Energy phases can be achieved.

							CENTERPOINT ENERGY HOUSTON, TX		
20	10/17/2024	Added 345kV Specification	Var	Var	JPB				
19	1/3/2024	Update to VRT in 3.5 and minor edits	Var	Var	PM	WRITTEN	4/9/74	E. C. Reid	
18	9/8/2023	Updates to various sections	Var	Var	PM	CHECKED	4/10/74	L. G. Pond	
17	9/2/2021	Update sections 4 & 11	Var	Var	GAC	APPROVED	7/17/74	C. S. Kayser	
							Page 17 of 46		
NO	DATE	ITEMS REVISED	BY	CH	APP	SPECIFICATION No. 007-2231-14			



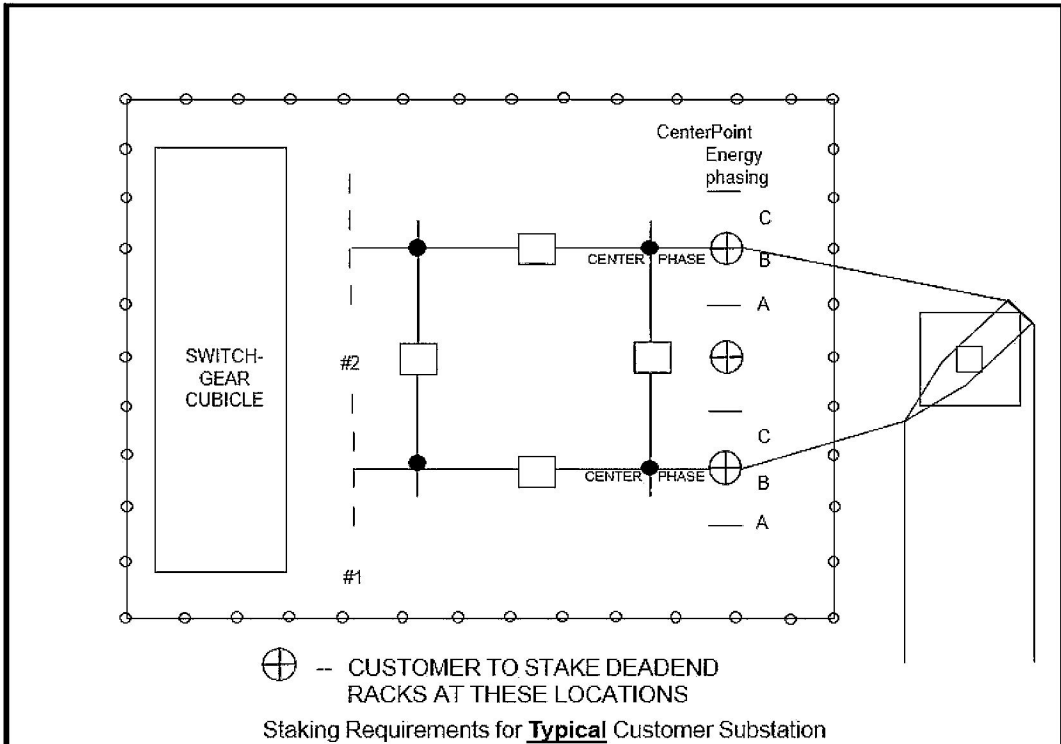

**Figure 10**

- 6.3. An all-weather access roadbed capable of supporting heavy construction vehicles shall be provided to the customer-owned substation. The areas within the customer-owned substations that need to support heavy vehicular traffic should conform to AASHTO H20 loading.
- 6.4. Access for CenterPoint Energy to attach its transmission line wires to the customer-owned substation dead-end structures shall be provided by either:
  - 6.4.1. A 25 ft. wide, leveled, and unobstructed access outside the customer-owned substation site from a main road to the CenterPoint Energy right-of-way and in front of the dead-end structures with substation fencing a maximum of 20 ft. from the attachment point of the dead-ends and a 13 ft. (minimum) wide gate for access into the customer-owned substation.
  - 6.4.2. A 25 ft. wide access inside the customer-owned substation from the substation access gate (20 ft. wide minimum) to the front of the dead-ends with substation fencing a minimum of 25 ft. from the attachment point.

						CENTERPOINT ENERGY HOUSTON, TX		
20	10/17/2024	Added 345kV Specification	Var	Var	JPB			
19	1/3/2024	Update to VRT in 3.5 and minor edits	Var	Var	PM	WRITTEN	4/9/74	E. C. Reid
18	9/8/2023	Updates to various sections	Var	Var	PM	CHECKED	4/10/74	L. G. Pond
17	9/2/2021	Update sections 4 & 11	Var	Var	GAC	APPROVED	7/17/74	C. S. Kayser
						Page 18 of 46		
<b>NO</b>	<b>DATE</b>	<b>ITEMS REVISED</b>	<b>BY</b>	<b>CH</b>	<b>APP</b>	SPECIFICATION No. 007-2231-14		

- 6.5. Access and space shall be provided for installation and future replacement of high voltage equipment including metering instrument transformers.
- 6.6. The design elevation of the customer-owned substation site, equipment and control cubicle should take into consideration locating essential components above flood and storm surge levels.

**7. HIGH VOLTAGE EQUIPMENT**

7.1. The requirements for power transformers are as follows:

- 7.1.1. Transformers serving load shall have a delta winding for connection to the 138 kV system. Power transformers shall conform to IEEE C57.12.00. Power transformers should be equipped with sudden pressure and low oil level detection devices.
- 7.1.2. Power transformers shall have a minimum of two 600:5 A multi-ratio bushing current transformers (BCTs) per 138 kV bushing. Each BCT shall have IEEE C57.13 accuracy C400 or better. Where applications require additional BCTs and/or different ratios, CenterPoint Energy shall provide ratios to support equipment purchase schedule. The secondary resistance of power transformer BCTs shall not exceed 0.0025 ohms per turn. The power transformer BCT secondary rated continuous current shall be 10 A minimum. The power transformer BCT rating factor (R.F.) shall equal 2.0.
- 7.1.3. High-side surge arresters shall be provided in accordance with Sub-Article 7.4 of this specification.
- 7.1.4. The customer shall determine the need for, and if applicable, settings for a transformer tap changer for de-energized operation (no load tap) and automatic on-load tap changer. CenterPoint Energy recommends power transformers be equipped with an automatic on-load tap changer.

7.2. The requirements for circuit breakers are as follows:

- 7.2.1. Circuit breakers shall be of the three-pole, outdoor type, 138 kV nominal, in accordance with IEEE C.37.04.
- 7.2.2. For a "full loop" customer-owned substation, "loop tap" substation, or a substation arranged for future "full loop" service, the 138 kV circuit breakers that are or will be in the substation "loop" shall have a continuous current rating of 4,000 A, an overload capability of 110 percent of the rated current for 2 hours and a rated isolated capacitor bank current switching capability of 600 A.

For customer-owned substations connecting to four or more 138 kV CenterPoint Energy transmission lines, circuit breakers may be required to have a higher continuous rating. The three-phase symmetrical short circuit current interrupting capability of all 138 kV circuit breakers shall be 63 kA rms symmetrical. The rated interrupting time of all 138 kV circuit breakers shall be three cycles or less. In some applications, the installation of TRV shaping capacitors may be required in order to achieve the circuit breaker interrupting capability of 63 kA rms symmetrical for line faults. CenterPoint Energy shall determine the placement of

							CENTERPOINT ENERGY HOUSTON, TX		
20	10/17/2024	Added 345kV Specification	Var	Var	JPB				
19	1/3/2024	Update to VRT in 3.5 and minor edits	Var	Var	PM	WRITTEN	4/9/74	E. C. Reid	
18	9/8/2023	Updates to various sections	Var	Var	PM	CHECKED	4/10/74	L. G. Pond	
17	9/2/2021	Update sections 4 & 11	Var	Var	GAC	APPROVED	7/17/74	C. S. Kayser	
Page 19 of 46									
NO	DATE	ITEMS REVISED	BY	CH	APP	SPECIFICATION No. 007-2231-14			

TRV shaping capacitors, when required for line faults.

- 7.2.3. Each 138 kV circuit breaker shall be equipped with two 4000:5 A multi-ratio BCTs per 138 kV bushing. Each circuit breaker BCT shall have a relaying accuracy class of C800 on the 4000:5 A tap in accordance with IEEE C57.13. The secondary resistance of the circuit breaker BCT shall not exceed 0.0025 ohms per turn. The circuit breaker BCT secondary rated continuous current shall be 10 A minimum. The circuit breaker BCT rating factor (R.F.) shall equal 2.0.

For the replacement or addition of a 138 kV circuit breaker in an existing customer-owned substation that already has other 138 kV circuit breakers that do not have a continuous current rating of 4,000 A, the following applies to the replacement or addition circuit breaker (i.e., the following requirement is to accommodate interface of the 4000 A replacement or addition 138 kV circuit breaker with any existing circuit breakers that have 2000:5 multi-ratio BCTs in an existing substation while maintaining the design capability for 4000 ampere operation in the future). Each replacement or addition 138 kV circuit breaker shall be equipped with two 3000:5 A multi-ratio BCTs per 138 kV bushing. Each circuit breaker BCT shall have a relaying accuracy class of C800 on the 2000:5 A tap (equivalent to C1200 on the full ratio 3000:5) in accordance with IEEE C57.13. The secondary resistance of circuit breaker BCTs shall not exceed 0.0025 ohms per turn. Circuit breaker BCT secondary rated continuous current shall be 10 A minimum. Circuit breaker BCT rating factor (R.F.) shall equal 2.0.

- 7.2.4. Two trip circuits shall be provided with independent 125 V DC control circuits. If two trip coils operate a single armature, both coils shall be designed or marked in such a way as to prevent their being connected in a manner that would result in the circuit breaker not tripping in the event that both coils are energized simultaneously.
- 7.2.5. Trip circuit or close circuit DC current shall not exceed 15 A (instantaneous and steady state) for the circuit breaker trip or close circuit. If electromechanical protective relays with DC operated 'target and seal-in' units are used in the substation, then the circuit breaker trip circuit shall not draw less than 4 A DC current and a circuit breaker close circuit shall not draw less than 2 A DC current in order ensure reliable 'target and seal-in' unit operation.
- 7.2.6. The DC negative of a trip circuit shall not be fused or use a circuit breaker inside the circuit breaker control cabinet.
- 7.2.7. Surge suppression shall be provided on each trip and close coil. Reference CenterPoint Energy 007-400-02 Specification for Remote Telemetry of a Customer-Owned Facility.
- 7.2.8. The circuit breaker operating mechanism shall be both mechanically and electrically trip-free in any position. For oil circuit breakers, a latch check switch shall be provided.
- 7.2.9. Circuit breakers with air closing mechanisms shall have stored energy for at least 5 close-open operations. Circuit breakers with spring closing mechanisms shall have the spring charging motor circuit connected to a 125 V DC battery source utilizing a DC supply cable dedicated for this purpose. Voltage rollover from AC to DC shall not be installed for the spring charging motor circuit for circuit breakers.
- 7.2.10. Gas circuit breakers shall have low SF6 gas pressure alarm and close inhibit contacts.

							CENTERPOINT ENERGY HOUSTON, TX		
20	10/17/2024	Added 345kV Specification	Var	Var	JPB				
19	1/3/2024	Update to VRT in 3.5 and minor edits	Var	Var	PM	WRITTEN	4/9/74	E. C. Reid	
18	9/8/2023	Updates to various sections	Var	Var	PM	CHECKED	4/10/74	L. G. Pond	
17	9/2/2021	Update sections 4 & 11	Var	Var	GAC	APPROVED	7/17/74	C. S. Kayser	
							Page 20 of 46		
NO	DATE	ITEMS REVISED	BY	CH	APP	SPECIFICATION No. 007-2231-14			

The customer shall indicate on the relay and metering one-line diagram whether the low SF6 gas pressure wiring is set to 'BLOCK TRIP' or to 'AUTO TRIP' the circuit breaker.

- 7.2.11. Circuit breaker internal time delay circuitry for reclosing shall not be utilized. External time delayed automatic reclosing, when utilized, shall be wired/connected directly to the circuit breaker close circuit. External time delay for the circuit breaker closing circuit is to be provided by the automatic reclosing scheme.
- 7.2.12. The circuit breaker internal close and trip circuits shall not go through a 'local/remote' control switch in the circuit breaker. However, if a circuit breaker comes from the manufacturer with a 'local/remote' control switch installed in the circuit breaker, then the 'remote' contact of the control switch that is wired in series with the close and trip circuits must be shorted out or by-passed.

7.3. The requirements for air break switches are as follows:

- 7.3.1. Transmission line disconnect switches and all disconnect switches in the customer-owned substation 'loop' shall be of the outdoor, three pole, gang operated type rated 145 kV nominal, and shall have minimum continuous current rating of 4000 A, an overload capability of 110 percent of rated current for 2 hours and a rated minimum withstand capability of 164 kA peak for at least 1.5 seconds. Disconnect switches that are not in the substation 'loop' (i.e., transformer high-side disconnect switch) may be rated for less than 4000 A continuous, but must have a rated minimum withstand capability of 164 kA peak. The switch air gap BIL shall coordinate with the BIL rating of the switch insulators. For customer-owned substations connecting to four or more CenterPoint Energy 138 kV transmission lines, contact CenterPoint Energy for the required rating of switches.
- 7.3.2. Transmission line disconnect switches are required for all substation types.
- 7.3.3. "Loop tap" substations must be configured and designed with equipment to permit switching for the scheduled outage of either transmission line section without interrupting service to the customer's load. An interrupting device attached to a disconnect switch in a "loop tap" substation for transmission line load breaking, loop switching or line dropping is not acceptable.
- 7.3.4. CenterPoint Energy does not require any 138 kV disconnect switch auxiliary contacts except as indicated in Sub-Article 9.1.5 of this specification.
- 7.3.5. Grounding switches are not permitted on 138 kV equipment. A 'grounding stud' or fabricated attachment for the application of temporary grounding cables may be installed if desired.

7.4. The requirements for surge arresters are as follows:

- 7.4.1. Surge arresters must be installed on 138 kV power transformers and in the substation on the incoming transmission line positions to protect substation 138 kV equipment including 138 kV coupling capacitors, line traps, instrument transformers, circuit breakers, etc.
- 7.4.2. All surge arresters shall be metal oxide type, 108 kV class minimum, with a minimum required maximum continuous over-voltage (MCOV) rating of 88 kV. The minimum required energy absorption capability is 7 kilojoules/ kV of MCOV rating. The surge arrester

							CENTERPOINT ENERGY HOUSTON, TX		
20	10/17/2024	Added 345kV Specification	Var	Var	JPB				
19	1/3/2024	Update to VRT in 3.5 and minor edits	Var	Var	PM	WRITTEN	4/9/74	E. C. Reid	
18	9/8/2023	Updates to various sections	Var	Var	PM	CHECKED	4/10/74	L. G. Pond	
17	9/2/2021	Update sections 4 & 11	Var	Var	GAC	APPROVED	7/17/74	C. S. Kayser	
Page 21 of 46									
NO	DATE	ITEMS REVISED	BY	CH	APP	SPECIFICATION No. 007-2231-14			

must have a minimum required pressure relief capability of 63 kA rms symmetrical (or short circuit current rating of 63 kA rms symmetrical). In addition to meeting the CenterPoint Energy minimum requirements, a surge arrester with well-designed directional pressure relief ports can provide a benefit. In the event of a surge arrester internal short circuit, a surge arrester with well-designed directional pressure relief vent ports, and with the vent ports pointed in the appropriate direction, can minimize the possibility that the ionized gas emitted from the surge arrester will propagate into a multiphase fault and can minimize the possibility of the ionized gas, and possibly other materials emitted from the surge arrester from causing damage to other equipment.

7.4.3. All 138 kV surge arresters must be connected with a copper bond wire from the bottom flange of the arrester to the substation ground mat. If the customer desires to allow for grading / leakage current monitoring, the surge arresters may be mounted on plates using insulated spacers and associated hardware. The insulated copper ground conductor from the bottom flange of the arrester must be isolated from any other ground until it passes the point where a long ammeter reading can be taken. The independent, insulated ground leads should be adequately marked to indicate A, B, and C phases.

7.5. The requirements for coupling capacitors or CVTs and line tuners are as follows:

7.5.1. CenterPoint Energy shall specify vendor and vendor style number for the coupling capacitor or CVT devices that are used for transmission line protective relaying or CenterPoint Energy supervisory control and data acquisition (SCADA) remote telemetry monitoring of CenterPoint Energy transmission lines according to CenterPoint Energy provided bill of materials. CenterPoint Energy shall specify vendor and vendor style number for the line tuners that are used for transmission line protective relaying according to CenterPoint Energy provided bill of materials.

7.5.2. The line tuner must be mounted at a level suitable for adjusting and testing while standing on the ground. The line tuner must be mounted at the base of the coupling capacitor stand to minimize the length of the carrier lead-in conductor connected between the line tuner and the coupling capacitor to reduce the stray capacitance and leakage to ground that will increase the losses of the tuner and affect the bandwidth.

7.5.3. The coupling capacitor or CVT shall not be used to structurally support the line trap. Refer to Sub-Article 7.6.3 of this specification.

7.6. The requirements for line-traps are as follows:

7.6.1. CenterPoint Energy shall specify vendor and vendor style number for line trap devices that are used for transmission line protective relaying according to CenterPoint Energy provided bill of materials.

7.6.2. The line trap shall have a minimum continuous current rating of 4,000 A, and an overload capability of 110 percent of the rated current for 2 hours.

7.6.3. The line trap shall not be structurally supported by a coupling capacitor or CVT. Refer to Sub-Article 7.5.3 of this specification.

							CENTERPOINT ENERGY HOUSTON, TX		
20	10/17/2024	Added 345kV Specification	Var	Var	JPB				
19	1/3/2024	Update to VRT in 3.5 and minor edits	Var	Var	PM	WRITTEN	4/9/74	E. C. Reid	
18	9/8/2023	Updates to various sections	Var	Var	PM	CHECKED	4/10/74	L. G. Pond	
17	9/2/2021	Update sections 4 & 11	Var	Var	GAC	APPROVED	7/17/74	C. S. Kayser	
Page 22 of 46									
NO	DATE	ITEMS REVISED	BY	CH	APP	SPECIFICATION No. 007-2231-14			

**8. CONTROL CUBICLE**

- 8.1. The control cubicle shall be a permanent, weatherproof structure constructed on a concrete foundation and scheduled for completion well in advance of the remainder of the substation to allow for adequate check out and testing. The ambient conditions inside the control cubicle shall not exceed 32°C (90°F) and 85% relative humidity. Adequate lighting shall be provided.
- 8.2. Wall space for metering boxes shall be provided in accordance with Sub-Article 9.1.3.1 of this specification.
- 8.3. If CenterPoint Energy has specified that transmission line protective relaying with power line carrier and/or fiber optic communication is utilized, power line carrier transmitter/receiver sets shall be procured by the customer according to CenterPoint Energy provided bill of material and/or the customer will provide wall space or floor space for a CenterPoint Energy provided fiber optic cable distribution box.
- 8.4. The customer shall provide space for the CenterPoint Energy remote telemetry equipment that will be installed in accordance with Sub-Article 12.1 of this specification.
- 8.5. A separate 120 V AC, 20 A circuit shall be provided to each of the following: (a) one of the metering boxes, (b) the power line carrier equipment location, and (c) the SCADA RTU cabinet (see CenterPoint Energy 007-400-02 Specification for Remote Telemetry of a Customer-Owned Facility).
- 8.6. One 120 V AC, 20 A outlet for protective relay testing equipment shall be located near the transmission line protective relays in the substation control cubicle.
- 8.7. A separate 130 VDC, 15 A circuit shall be provided to each of the following: (a) one of the metering boxes, and (b) the SCADA RTU cabinet (see CenterPoint Energy 007-400-02 Specification for Remote Telemetry of a Customer-Owned Facility).
- 8.8. If CenterPoint Energy transmission line fault location traveling wave system (TWS) equipment is to be installed, CenterPoint Energy will provide requirements.

**9. METERING EQUIPMENT**

- 9.1. The requirements for metering are as follows:
  - 9.1.1. Any part of the metering system that is installed by the customer or his agent shall conform to ANSI C12.1 at minimum, unless otherwise specified by CenterPoint Energy.
  - 9.1.2. The customer shall submit a one-line diagram of the proposed substation configuration to CenterPoint Energy in accordance with Article 14 of this specification. CenterPoint Energy will designate on the one-line diagram the location of all metering instrument transformers (including, without limitation, quantity, transformation ratios, voltage class - high-side or low-side and ratings). The metering instrument transformers shall be connected to the transformer low-side or to the 138 kV substation bus by the customer as specified by CenterPoint Energy.

							CENTERPOINT ENERGY HOUSTON, TX		
20	10/17/2024	Added 345kV Specification	Var	Var	JPB				
19	1/3/2024	Update to VRT in 3.5 and minor edits	Var	Var	PM	WRITTEN	4/9/74	E. C. Reid	
18	9/8/2023	Updates to various sections	Var	Var	PM	CHECKED	4/10/74	L. G. Pond	
17	9/2/2021	Update sections 4 & 11	Var	Var	GAC	APPROVED	7/17/74	C. S. Kayser	
Page 23 of 46									
NO	DATE	ITEMS REVISED	BY	CH	APP	SPECIFICATION No. 007-2231-14			

9.1.3. Metering boxes shall be located inside an environmentally controlled cubicle.

9.1.3.1. Each metering box is 30 inches wide, 42 inches high, 12 inches deep, wall mounted and approximately 36 inch from the floor. Wall space 3.0 ft. wide and 8.0 ft. high measured from the floor with 4.0 ft. (from wall) front clearance shall be provided for installation and maintenance of each metering box as illustrated in **Figure 11**. Metering boxes will be furnished by CenterPoint Energy and installed by the customer. The number of metering boxes will be determined by the metering scheme to be used.

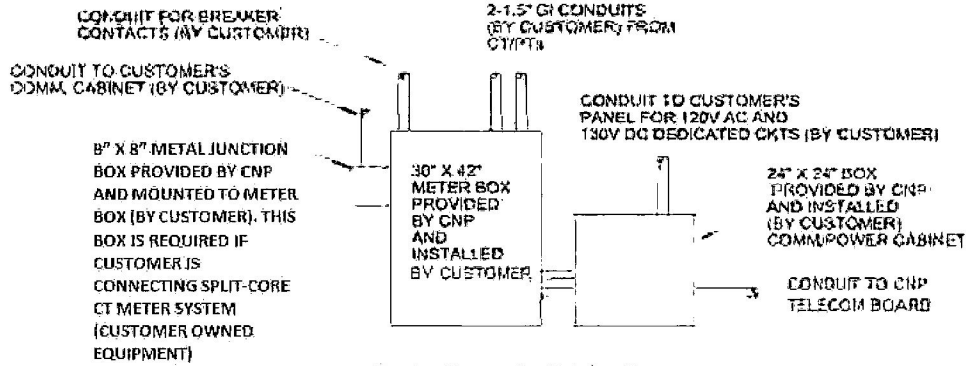

**Typical Layout of Meter Boxes**

**Figure 11**

9.1.3.2. A customer requesting metering data shall provide all conduits and wiring necessary to connect to a meter comm/power box provided by CenterPoint Energy and mounted on the metering installation.

9.1.3.3. The customer shall provide a conduit from the CenterPoint Energy telecom board to the metering comm/power box.

9.1.4. CenterPoint Energy personnel will make all meter connections. For metering equipment details, consult the CenterPoint Energy project representative.

9.1.5. When high-side metering is used in a "full loop" alternative 'c' or alternative 'd' type substation (see Figure 4 and Figure 5), the customer shall provide and wire two auxiliary '52a' contacts from the circuit breaker between the two transmission lines ("A" circuit breaker) and a single auxiliary '52a' contact for each of the other two transmission line circuit breakers ("B" and "C" circuit breakers) to the CenterPoint Energy high voltage metering box. Also, in a "full loop" alternative 'c' type substation (see Figure 4) with two transformer substation, two auxiliary '89a' contacts shall be provided on the disconnect switch between transformers and wired to the CenterPoint Energy high voltage metering box. When high-side metering is used in a "full loop" alternative 'e' type substation (see Figure 6), the customer shall provide

							CENTERPOINT ENERGY HOUSTON, TX		
20	10/17/2024	Added 345kV Specification	Var	Var	JPB				
19	1/3/2024	Update to VRT in 3.5 and mirror edits	Var	Var	PM	WRITTEN	4/9/74	E. C. Reid	
18	9/8/2023	Updates to various sections	Var	Var	PM	CHECKED	4/10/74	L. G. Pond	
17	9/2/2021	Update sections 4 & 11	Var	Var	GAC	APPROVED	7/17/74	C. S. Kayser	
							Page 24 of 46		
NO	DATE	ITEMS REVISED	BY	CH	APP	SPECIFICATION No. 007-2231-14			

and wire a single auxiliary '52a' contact for each of the other two transmission line circuit breakers ('A', 'B', 'C' and 'D' circuit breakers) to the CenterPoint Energy high voltage metering box. When high-side metering is used in a "loop tap" alternative 'b' type substation (see Figure 3), the customer shall provide two auxiliary '89a' contacts from the disconnect switch located in the substation bus between the transmission line connections and a single auxiliary '52a' contact from each of the circuit breakers. The customer shall provide and install cable from these contacts to the metering location (routed via the protective relay panels) for 'rollover' of the metering potential to a second set of potential transformers.

9.1.6. When low-side metering is utilized, as determined by CenterPoint Energy, customer shall provide and install 138 kV CVT devices in accordance with Sub-Article 7.5 of this specification.

9.2. The requirements for switchgear mounted metering instrument transformers are as follows:

9.2.1. Where low-side metering is used, as determined by CenterPoint Energy, the customer shall install CenterPoint Energy specified metering instrument transformers in their switchgear.

9.2.1.1. The customer shall purchase and install the CenterPoint Energy specified metering instrument transformers.

9.2.1.2. Original certified test data shall be provided to CenterPoint Energy for each metering instrument transformer installed.

9.2.2. Metering current transformers shall be located in the incoming main breaker cubicle. The metering current transformers shall be installed by the customer.

9.2.3. Metering potential transformers shall be located in roll-out boxes. The potential transformers shall be installed by the customer.

9.2.3.1. The secondary windings shall be used only for CenterPoint Energy metering.

9.2.3.2. Potential transformers shall be equipped with 1 A, current limiting primary fuses.

9.2.4. The customer shall install a 1.5 in. rigid galvanized steel conduit from each instrument transformer cubicle to the meter box.

9.2.5. CenterPoint Energy shall supply cable for all metering instrument transformer secondary connections. The customer shall pull the CenterPoint Energy provided cable. CenterPoint Energy shall make all metering instrument transformer secondary connections.

9.2.6. The customer shall supply copper ground wire from the customer's switchgear to the CenterPoint Energy meter box.

9.3. The requirements for 138 kV metering instrument transformers are as follows:

9.3.1. When 138 kV metering is used, CenterPoint Energy will furnish all 138 kV metering instrument transformers (i.e., separate 138 kV 'free-standing' current and potential transformers) required for CenterPoint Energy revenue metering or ERCOT Polled

							CENTERPOINT ENERGY HOUSTON, TX		
20	10/17/2024	Added 345kV Specification	Var	Var	JPB				
19	1/3/2024	Update to VRT in 3.5 and minor edits	Var	Var	PM	WRITTEN	4/9/74	E. C. Reid	
18	9/8/2023	Updates to various sections	Var	Var	PM	CHECKED	4/10/74	L. G. Pond	
17	9/2/2021	Update sections 4 & 11	Var	Var	GAC	APPROVED	7/17/74	C. S. Kayser	
							Page 25 of 46		
NO	DATE	ITEMS REVISED	BY	CH	APP	SPECIFICATION No. 007-2231-14			



Settlement metering ("EPS").

- 9.3.2. CenterPoint Energy will mount the instrument transformers on stands provided by the customer in accordance with Sub-Article 5.6 of this specification. The substation layout and location of the 138 kV metering instrument transformers shall incorporate the requirement of vehicle access up to the instrument transformers for installation, testing and future replacement (i.e., vehicle access not obstructed by substation bus, cable tray, etc.). The customer shall furnish flexible connections from the substation bus to the instrument transformers with NEMA CC 1 standard four-hole terminals (0.5625 in. diameter holes on 1.75 in. centers). CenterPoint Energy personnel will bolt the flexible connections to the instrument transformers.
- 9.3.3. The customer shall utilize rigid galvanized steel conduit, flexible metallic conduit and pull boxes, including pull string, for the cables/conductors from the metering instrument transformers to the metering box location.
  - 9.3.3.1. For each set of current or potential transformer stands, 1.50 in. rigid galvanized steel conduit shall be used to connect the individual instrument transformers to a common junction box for this set of instrument transformers (i.e., one common junction box for each set of current or potential transformer stands) located on or near the base of one of the instrument transformer stands. The 1.50 in. conduit shall terminate within 12 in. from the top of each instrument transformer stand. A 2.00 in. rigid galvanized steel conduit shall be used from each common junction box located at the base of one of the instrument transformer stands to the metering box.
  - 9.3.3.2. All 2.00 in. rigid galvanized steel conduit shall terminate at the base of the primary metering box. No more than four conduits are to be terminated in a metering box. Contact CenterPoint Energy if additional conduits are required.
  - 9.3.3.3. Flexible metallic conduit shall be used as needed to complete the installation to the instrument transformers, common junction boxes, and the metering box(es).
- 9.3.4. Potential transformers for revenue metering located in the 138 kV substation yard shall be furnished and installed by CenterPoint Energy on instrument transformer stands provided by the customer. The potential transformers will be rated 80,500/115-67.08 V for use on 138 kV grounded neutral system in accordance with IEEE C57.13.
  - 9.3.4.1. The potential transformers will have three secondary windings (i.e., "X", "Y", and "Z"). The "X" and "Z" windings will be used for transmission line protective relaying, SCADA and the customer's equipment. The "Y" winding will be used exclusively for CenterPoint Energy metering.
  - 9.3.4.2. A minimum 16 inches wide, 14 inches high, 6 inches deep potential transformer common junction box and secondary fuses shall be provided and installed by the customer and located at the base of one of the potential transformer stands. Each secondary winding shall be separately fused at the potential transformer junction box to provide circuit isolation and short circuit protection; except that neutrals shall not be fused (brass or copper dummy fuses required).

						CENTERPOINT ENERGY HOUSTON, TX		
20	10/17/2024	Added 345kV Specification	Var	Var	JPB			
19	1/3/2024	Update to VRT in 3.5 and minor edits	Var	Var	PM	WRITTEN	4/9/74	E. C. Reid
18	9/8/2023	Updates to various sections	Var	Var	PM	CHECKED	4/10/74	L. G. Pond
17	9/2/2021	Update sections 4 & 11	Var	Var	GAC	APPROVED	7/17/74	C. S. Kayser
						Page 26 of 46		
NO	DATE	ITEMS REVISED	BY	CH	APP	SPECIFICATION No. 007-2231-14		

- 9.3.4.3. CenterPoint Energy shall supply cable/conductors for the potential transformers "Y" winding secondary connections. The customer shall supply cable/conductors for the potential transformers "X" and "Z" windings secondary connections. The customer shall pull the CenterPoint Energy provided cable/conductors and customer supplied cable/conductors. CenterPoint Energy shall make the potential transformers "Y" winding secondary connections. The customer shall make the potential transformers "X" and "Z" windings secondary connections. The potential transformer cables/conductors shall be connected as shown on CenterPoint Energy drawing 581-500-01 138 kV Potential Transformer Schematic and Wiring Diagram.
- 9.3.4.4. The potential transformer primary shall be wye connected with a solid ground connection at the potential transformer location. The potential transformer secondary windings shall be wye connected with one neutral conductor per set of "X" and "Z" windings carried to the transmission line protective relay panel and another neutral conductor for the "Y" winding will be carried to the meter box, as shown on CenterPoint Energy Drawing 581- 500-01 138 kV Potential Transformer Schematic and Wiring Diagram. These neutral conductors shall be grounded at the transmission line protective relay panel and meter box only.
- 9.3.4.5. If any 138 kV potential transformer "X" or "Z" winding of any phase is not used for any relaying, SCADA or customer's equipment, the secondary "3" terminal of any unused winding must be connected to a conductor that is grounded at a panel in the control cubicle.
- 9.3.5. Metering current transformers located in the 138 kV substation yard shall be furnished and installed by CenterPoint Energy on instrument transformer stands provided by customer.
  - 9.3.5.1. CenterPoint Energy shall supply cable for the metering current transformer's secondary connections. The customer shall pull the CenterPoint Energy provided cable. CenterPoint Energy shall make the metering current transformer's secondary connections.
  - 9.3.5.2. A minimum 16 inches wide, 14 inches high, 6 inches deep current transformer common junction box shall be provided and installed by the customer and located at the base of one of the current transformer stands.
- 9.3.6. The customer shall provide a copper bond wire from the ground mat to the case of each instrument transformer. The wire shall be sized equal to the ground mat. CenterPoint Energy will terminate and connect the wire at the instrument transformer case.

**10. FUSING AND CONNECTION OF PROTECTION AND CONTROL AND METERING CIRCUITS**

10.1. Mersen Ferraz Shawmut type A2Y, A2K or A2D or Littelfuse type KLNR fuses shall be used for fusing of the 138 kV potential transformers secondary relaying and metering circuits of less than 250 V AC as follows:

10.1.1. 138 kV potential transformers secondary "X" winding and "Z" winding shall be fused with 30 A fuses at the potential transformer junction box in the yard except that neutrals shall not

							CENTERPOINT ENERGY HOUSTON, TX		
20	10/17/2024	Added 345kV Specification	Var	Var	JPB				
19	1/3/2024	Update to VRT in 3.5 and minor edits	Var	Var	PM	WRITTEN	4/9/74	E. C. Reid	
18	9/8/2023	Updates to various sections	Var	Var	PM	CHECKED	4/10/74	L. G. Pond	
17	9/2/2021	Update sections 4 & 11	Var	Var	GAC	APPROVED	7/17/74	C. S. Kayser	
Page 27 of 46									
NO	DATE	ITEMS REVISED	BY	CH	APP	SPECIFICATION No. 007-2231-14			

- be fused (brass or copper dummy fuses required).
- 10.1.2. 138 kV potential transformers secondary "Y" windings shall be fused with 60 A fuses at the potential transformer junction box in the yard except that neutrals shall not be fused (brass or copper dummy fuses required).
- 10.1.3. 15 A fuses shall be used for protective relaying potential branch circuits.
- 10.1.4. 6 A fuses shall be used for instrumentation potential branch circuits.
- 10.2. Mersen Ferraz Shawmut type A2Y, A2K or A2D or Littelfuse type KLNR fuses shall be used for fusing of 138 kV coupling CVT secondary relaying and instrumentation circuits of less than 250 V AC as follows:
  - 10.2.1. CVT secondary windings shall be fused with 6 A secondary fuses at the CVT junction box in the yard except that neutrals shall not be fused.
  - 10.2.2. 3 A fuses shall be used for protective relaying potential branch circuits.
- 10.3. Mersen Ferraz Shawmut type A2Y, A2K or A2D or Littelfuse type KLNR fuses shall be used for fusing of relaying DC circuits of less than 250 V DC as follows:
  - 10.3.1. The trip circuit connection from the control cubicle panel to each 138 kV breaker trip coil shall be fused with a 15 A panel mounted fuse located on the appropriate control cubicle panel.
  - 10.3.2. 30 A fuses shall be used for the CenterPoint Energy SCADA control positive.
- 10.4. The voltage drop from the control cubicle to the trip circuit at the circuit breakers shall not exceed 10% of rated battery voltage under normal expected operating conditions.
  - 10.4.1. With outdoor circuit breakers and indoor protective relay and control panels, a routing method herein called "radial", shall be used since the dc circuitry to the circuit breakers radiates outward from the control cubicle. Routing of the conductors is from the dc supply to the protective relay and control panels or switchboards and then on to the circuit breakers. Positive and negative conductors are carefully routed together so that sudden changes in current, such as those from tripping a circuit breaker, do not result in large magnetic coupling to other control and measuring conductors. The effects of external magnetic fields tend to cancel when the "go" and "return" conductors are in close proximity. All wires of a circuit should be contained in the same cable so that all are affected similarly by any inductive coupling.

							CENTERPOINT ENERGY HOUSTON, TX		
20	10/17/2024	Added 345kV Specification	Var	Var	JPB				
19	1/3/2024	Update to VRT in 3.5 and minor edits	Var	Var	PM	WRITTEN	4/9/74	E. C. Reid	
18	9/8/2023	Updates to various sections	Var	Var	PM	CHECKED	4/10/74	L. G. Pond	
17	9/2/2021	Update sections 4 & 11	Var	Var	GAC	APPROVED	7/17/74	C. S. Kayser	
							Page 28 of 46		
NO	DATE	ITEMS REVISED	BY	CH	APP	SPECIFICATION No. 007-2231-14			

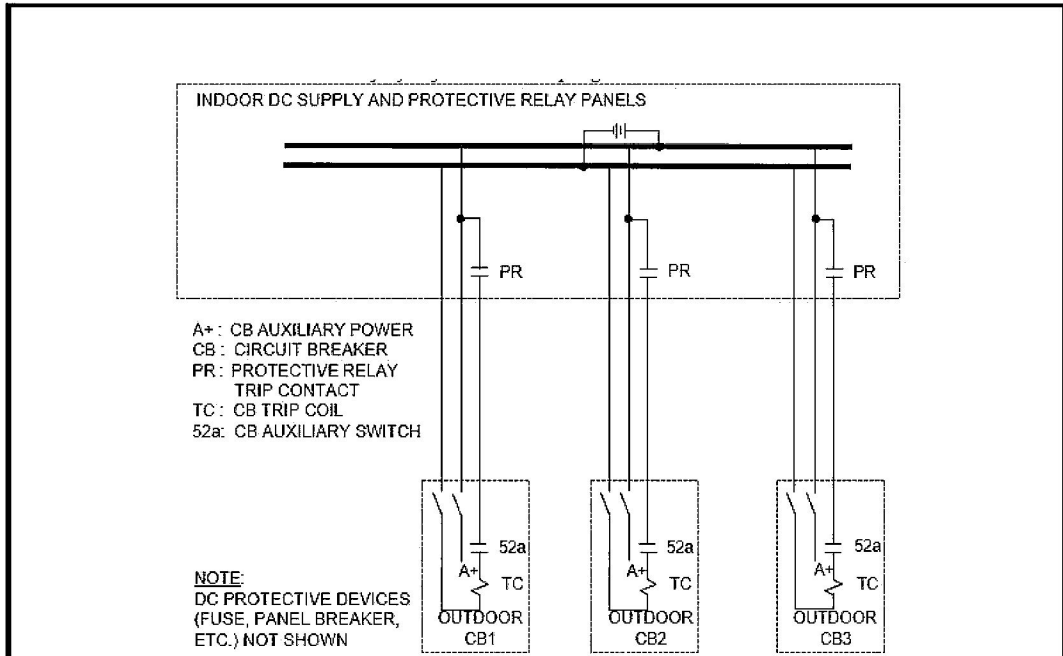

**11. PROTECTIVE RELAYING FOR HIGH VOLTAGE (138 KV)**

11.1. The customer will procure and own all the protective relays in the substation. A “full loop” substation configuration requires 138 kV transmission line protective relaying (including transmission line protective relay communication channels), 138 kV transmission line automatic reclosing and local breaker failure relaying for all 138 kV circuit breakers. CenterPoint Energy will specify in a bill of materials, as indicated in Sub-Article 11.3 of this specification, the protective relay style numbers for the multifunction (i.e., 138 kV transmission line protective relaying, circuit breaker automatic reclosing and local breaker failure relaying) microprocessor 138 kV transmission line protective relays. If the customer desires to install single function protective relays that are dedicated for breaker failure relaying, then the customer must consult CenterPoint Energy during the development of the relaying and metering one line diagram regarding which relays CenterPoint Energy personnel will calculate relay settings, apply the settings and test. CenterPoint Energy will specify in a bill of materials, as indicated in Sub-Article 11.3 of this specification, the manufacturer and protective relay type for the single function protective relays that are dedicated for breaker failure relaying. CenterPoint Energy will calculate and implement relay settings for customer-owned 138 kV transmission line protective relays, for single function protective relays that are dedicated for breaker failure relaying for only the circuit breakers that switch the CenterPoint Energy transmission lines and for customer-owned 138 kV relays installed to prevent back-energizing CenterPoint Energy’s

						CENTERPOINT ENERGY HOUSTON, TX		
20	10/17/2024	Added 345kV Specification	Var	Var	JPB			
19	1/3/2024	Update to VRT in 3.5 and mirror edits	Var	Var	PM	WRITTEN	4/9/74	E. C. Reid
18	9/8/2023	Updates to various sections	Var	Var	PM	CHECKED	4/10/74	L. G. Pond
17	9/2/2021	Update sections 4 & 11	Var	Var	GAC	APPROVED	7/17/74	C. S. Kayser
						Page 29 of 46		
NO	DATE	ITEMS REVISED	BY	CH	APP	SPECIFICATION No. 007-2231-14		

transmission system from generation installed on the low-side of customer power transformers. CenterPoint Energy will not consider customer requests for programming additional items in the transmission line protective relay for customers use (i.e., relay elements, inputs or outputs, etc.). The customer may request information be exported from the transmission line protective relay that are CenterPoint Energy’s standard programming of the relay (i.e., metering values, events, relay elements, inputs or outputs, etc.) via a communication port to the CenterPoint Energy SCADA RTU. On a case-by-case basis, CenterPoint Energy may issue settings for other customer-owned relays. In accordance with Sub-Articles 11.2 and 11.3, and 11.5 of this specification, the customer will propose 138 kV bus, 138 kV transformer protective relay schemes and, for “full loop” substation configurations, breaker failure relaying for all circuit breakers that do not switch the CenterPoint Energy transmission lines. The customer shall submit to CenterPoint Energy the customer calculated relay settings for, and allow CenterPoint Energy to observe the functional testing of, the 138 kV bus and 138 kV transformer protective relay schemes and breaker failure relaying for all circuit breakers that do not switch the CenterPoint Energy transmission lines.

11.2. Protective relaying for elements that compose the 138 kV facilities (i.e., 138 kV transmission lines, 138 kV buses, 138 kV power transformers, etc.) shall consist of two independent schemes for the protection of each element. The protective relays associated with the first scheme shall be connected to a different set of current transformers than the relays associated with the second scheme. The DC branch circuit associated with one relaying scheme (i.e., relay power supply, input, outputs, etc.) shall be a different DC branch circuit than the DC branch circuit associated with the second relaying scheme (i.e., independent DC branch circuit). Each of the two schemes shall energize both trip coils of a circuit breaker using appropriate DC separation and separate output contacts.

11.3. To ensure coordination with other transmission system protective relaying for a “full loop” substation configuration, CenterPoint Energy will furnish typical AC and DC schematics and a minimum required bill of materials for the protective relay style numbers for the multifunction (i.e., 138 kV transmission line protective relaying, circuit breaker automatic reclosing and local breaker failure relaying) microprocessor 138 kV transmission line protective relays including protective relay communication channel equipment. The customer shall indicate the CenterPoint Energy specified transmission line protective relaying schemes and proposed relaying schemes for each 138 kV bus (including 138 kV transformer high-side bus) and transformer protection on a substation relaying and metering one line diagram. Once CenterPoint Energy has reviewed these schemes, the customer shall submit the appropriate relaying drawings and customer’s bill of materials to CenterPoint Energy for functional review. After these drawings and the bill of materials are reviewed by CenterPoint Energy, the customer shall order the appropriate equipment and install these schemes. CenterPoint Energy personnel will calculate set points for the multifunction microprocessor 138 kV transmission line protective relays, apply the settings and test the transmission line protection relays after the customer has completed point- to-point wiring checks of protective relaying and control panels and verified protective relaying control circuits by performing functional trip and close testing as described in Article 16 of this specification. The customer shall calculate set points for the 138 kV bus and transformer protection relays and submit this information to CenterPoint Energy for review. After CenterPoint Energy has reviewed the 138 kV bus and transformer protection set points, the customer will apply the settings and test the relays after the customer has completed point-to-point wiring checks of protective relaying and control panels and verified protective relaying control circuits by performing functional trip and close testing as described in Article 16 of this specification. **IT SHALL BE THE CUSTOMER’S RESPONSIBILITY TO INSTALL ALL WIRING AND PERFORM ALL POINT-TO-POINT WIRING CHECKS AND CORRECT ANY WIRING**

							CENTERPOINT ENERGY HOUSTON, TX		
20	10/17/2024	Added 345kV Specification	Var	Var	JPB				
19	1/3/2024	Update to VRT in 3.5 and minor edits	Var	Var	PM	WRITTEN	4/9/74	E. C. Reid	
18	9/8/2023	Updates to various sections	Var	Var	PM	CHECKED	4/10/74	L. G. Pond	
17	9/2/2021	Update sections 4 & 11	Var	Var	GAC	APPROVED	7/17/74	C. S. Kayser	
							Page 30 of 46		
NO	DATE	ITEMS REVISED	BY	CH	APP	SPECIFICATION No. 007-2231-14			

**ERRORS.**

- 11.4. A "Sync Panel" is required only for a "full loop" substation configuration. The Sync Panel consists of a synchroscope, a voltmeter and three sync lights. The "Sync Panel" typically consists of a small subpanel mounted on hinges to one of the substation protection and control panels and must be visible from the location of the 138 kV circuit breaker control switches. Other arrangements may be acceptable (i.e., "Sync Panel" components mounted on the same protection and control panel that all of the 138 kV circuit breaker control switches are mounted on). CenterPoint Energy will specify the "Sync Panel" requirements in a bill of materials referenced in Sub-Article 14.1.2 of this specification.
- 11.5. For "full loop" substations equipped with transmission line protective relaying, the current carrying capability of the components in the protective relaying schemes (relay devices, auxiliary current transformers, monitoring devices, current test switches, terminal connectors, switchboard panel wiring, cable, etc.) shall meet a minimum continuous secondary current rating equivalent to a primary continuous ampere rating of 4,000A and 2-hr emergency ampere rating of 4,400A, unless otherwise specified by CenterPoint Energy. For substations with four or more 138kV transmission lines, the continuous and 2-hr emergency ratings of this equipment may be required to be greater than these values.
- 11.6. The following are minimum requirements for 138 kV bus and transformer protection:
  - 11.6.1. Bus protection shall include two independent instantaneous bus differential protective relays (device function 87). A power transformer connected to a bus position will utilize the same two sets of power transformer high-side BCTs (Sub-Article 7.1.2) for both the bus differential protective relays and the power transformer protective relays (Sub-Article 11.6.2). For a Figure 2 substation configuration, instantaneous overcurrent protective relays (device function 50) may be utilized for protection of the bus between the 138 kV circuit breaker and the 138 kV transformer high-side.
  - 11.6.2. Each power transformer shall be protected by two protective relays. As a minimum, one of the power transformer protective relays shall be a transformer differential relay (device function 87T), which shall be connected to one of the two sets of power transformer high-side BCTs and the other power transformer protective relay shall have instantaneous and time overcurrent relay (device function 50/51) which shall be connected to a different set of power transformer high-side BCTs than the transformer differential relay. If two multifunction microprocessor current differential protective relays are utilized, CenterPoint Energy does not object to the implementation of both a transformer differential function and a transformer instantaneous/time overcurrent function in each of the two protective relays.
  - 11.6.3. The three-line AC schematic drawing(s) showing bus differential protective relay connections and transformer protective relay connections should clearly indicate polarity markings on all current transformers and all protective relay current inputs.
  - 11.6.4. Power transformer sudden pressure relay and oil level device(s) should be connected for alarming and tripping. The sudden pressure relay and oil level device(s) should be connected to a different, independent DC branch circuit than the transformer differential relay.
  - 11.6.5. If auxiliary relays (device function 94) or lockout relays (device function 86) are used for

							CENTERPOINT ENERGY HOUSTON, TX		
20	10/17/2024	Added 345kV Specification	Var	Var	JPB				
19	1/3/2024	Update to VRT in 3.5 and minor edits	Var	Var	PM	WRITTEN	4/9/74	E. C. Reid	
18	9/8/2023	Updates to various sections	Var	Var	PM	CHECKED	4/10/74	L. G. Pond	
17	9/2/2021	Update sections 4 & 11	Var	Var	GAC	APPROVED	7/17/74	C. S. Kayser	
							Page 31 of 46		
NO	DATE	ITEMS REVISED	BY	CH	APP	SPECIFICATION No. 007-2231-14			

tripping, then two independent relays are required for each tripping zone. The auxiliary relays or lockout relays should be connected to different, independent DC branch circuits.

11.7. All 138 kV circuit breakers connected to a new 138 kV “full loop” substation are required to incorporate local breaker failure relaying. Local breaker failure relaying may be required for each 138 kV circuit breaker at existing substations when deemed necessary by CenterPoint Energy. When practical, the protective relay performing the breaker failure function shall directly trip all appropriate 138 kV circuit breakers (i.e., not utilize an auxiliary relay, a lockout relay or another protection relay to trip the appropriate 138 kV circuit breakers). CenterPoint Energy personnel will calculate set points, apply the settings and test the breaker failure scheme if it is incorporated in transmission line protective relays. If the customer desires to install single function protective relays that are dedicated for breaker failure relaying, then the customer must consult CenterPoint Energy during the development of the relaying and metering one line diagram (described in Sub-Article 14.1.2 of this specification) regarding which relays CenterPoint Energy personnel will calculate set points, apply the settings and test. CenterPoint Energy personnel will calculate set points, apply the settings and test the breaker failure scheme if it is incorporated in single function protective relays that are dedicated for breaker failure relaying but only for the circuit breakers that switch the CenterPoint Energy transmission lines. Testing of the breaker failure scheme in relays set by CenterPoint Energy will occur after the customer has completed the installation and has satisfactorily performed the system operational tests provided in Article 16 of this specification. IT SHALL BE THE CUSTOMER’S RESPONSIBILITY TO INSTALL ALL WIRING AND PERFORM ALL POINT-TO-POINT WIRING CHECKS AND CORRECT ANY WIRING ERRORS.

11.8. The following are specified for connections pertaining to protection and control cables:

- 11.8.1. Connections from one panel to another panel should be made from the terminal blocks on one panel to terminal blocks on the other panel (rather than directly from a device on one panel to a device on a different panel)
- 11.8.2. Protection and control cables should be color-coded and clearly marked to facilitate wire checking and troubleshooting.
- 11.8.3. Current transformer secondary cables shall be grounded only at the relay panels on the non-polarity side of the wye-connected current transformer.

11.9. CenterPoint Energy encourages the use of sequence of events recorders (SERs) and digital fault recorders (DFRs). The application of these systems involves trade-offs between the desire to monitor and record as much information as possible and the need to minimize the number of devices in protective relaying circuits to ensure reliable operation. Any customer planning to install one of these systems is encouraged to discuss their application philosophy with CenterPoint Energy early in the project and to show these devices in the appropriate relaying and SCADA AC and DC schematics when those drawings are submitted for CenterPoint Energy review.

11.10. Customer-owned Intelligent Electronic Devices (IEDs) with settings maintained by CenterPoint Energy (i.e. protective relays associated with CenterPoint Energy transmission network) are not allowed to be monitored directly by the customer. The data from these IEDs can be provided to the customer from a serial port on the CenterPoint Energy SCADA RTU.

							CENTERPOINT ENERGY HOUSTON, TX		
20	10/17/2024	Added 345kV Specification	Var	Var	JPB				
19	1/3/2024	Update to VRT in 3.5 and minor edits	Var	Var	PM	WRITTEN	4/9/74	E. C. Reid	
18	9/8/2023	Updates to various sections	Var	Var	PM	CHECKED	4/10/74	L. G. Pond	
17	9/2/2021	Update sections 4 & 11	Var	Var	GAC	APPROVED	7/17/74	C. S. Kayser	
							Page 32 of 46		
NO	DATE	ITEMS REVISED	BY	CH	APP	SPECIFICATION No. 007-2231-14			

11.10.1. The customer is permitted to connect directly (routable or non-routable communications) to IEDs with settings not maintained by CenterPoint Energy including SCADA electronic meters and microprocessor relays.

11.11. The following are specified for protective relay communication channels:

11.11.1. If the transmission line protective relaying utilized requires power line carrier communication, the power line carrier transmitter/receiver sets shall be located inside the substation control cubicle. The associated power line carrier coaxial cable utilized for making the connection from the substation control cubicle to the line tuner located near the 138 kV coupling capacitor shall be type RG-8/U, 11 AWG, stranded (7/19) bare copper, polyethylene dielectric, 50 ohm nominal impedance, with polyethylene outer jacket. (Note: If an alternate cable is used, an outer jacket with "Excellent" or "Outstanding" water resistance characteristic is required - PVC jacket is not acceptable). The line tuner requires separate mounting at the base of the coupling capacitor stand. A single conductor must be run as directly as possible between this line tuner and the coupling capacitor base housing. The single conductor must be 4 AWG stranded, 5 kV, non-shielded, XLP insulation. The single conductor must be mounted on insulators and fed through bushings at each end. The single conductor insulation should be unbroken between its ends to maintain low leakage. The single conductor must not be directly up against or touching the coupling capacitor support column or other metal components. The insulated single conductor lead-in can be installed in a PVC or other plastic conduit which should be supported on stand-offs or insulators.

11.11.2. When power line carrier communication is utilized, CenterPoint Energy shall determine the frequency for the power line carrier communication. The customer shall procure the power line carrier transmitter/receiver set with an automatic carrier tester according to CenterPoint Energy provided bill of material as indicated in Sub-Article 7.5 and 7.6 of this specification.

11.11.3. If transmission line protective relaying with fiber optics communication is utilized, the customer is required to provide a raceway for the fiber optic cable installation from the transmission line protective relay that requires the fiber optic communication (i.e., relay located in the substation control cubicle) to the base of the first CenterPoint Energy transmission line structure outside the substation. See Sub-Article 5.5.4 of this specification for cases where fiber optic cable comes in overhead. A dedicated raceway (conduit) is required for the fiber optic cable, however a dedicated inner duct installed in a cable trench or a dedicated conduit in a duct bank is acceptable. CenterPoint Energy shall be responsible for supplying, pulling and splicing of the fiber optic cable.

The following guidelines are for the customer provided raceway:

11.11.3.1. Flexible steel conduit 1.50 in. diameter, from the splice box, that is provided and mounted by CenterPoint Energy at the base of the first CenterPoint Energy transmission structure outside of the substation, to the end of the underground conduit provided by the customer.

11.11.3.2. Below grade conduit shall be a minimum 1.50 in. diameter PVC, Schedule 40 with "pull line" (continuous fiber polyolefin, 200 lbs. tensile strength) installed. Conduit shall be at least 18.00 in. below grade, with a protective concrete barrier. The minimum

							CENTERPOINT ENERGY HOUSTON, TX		
20	10/17/2024	Added 345kV Specification	Var	Var	JPB				
19	1/3/2024	Update to VRT in 3.5 and minor edits	Var	Var	PM	WRITTEN	4/9/74	E. C. Reid	
18	9/8/2023	Updates to various sections	Var	Var	PM	CHECKED	4/10/74	L. G. Pond	
17	9/2/2021	Update sections 4 & 11	Var	Var	GAC	APPROVED	7/17/74	C. S. Kayser	
Page 33 of 46									
NO	DATE	ITEMS REVISED	BY	CH	APP	SPECIFICATION No. 007-2231-14			



bending radius shall be 24.00 in.

- 11.11.3.3. Pull boxes at grade level shall be provided along the cable raceway route at intervals not more than 300 ft. or two 90° bends. A cable pull box in the raceway route is required just inside the substation fence. Pull box shall be 30 in. x 60 in. x 30 in. (Quazite Style No. PG3060BB30 and PG3060HA).
- 11.11.3.4. The customer shall provide 5 in. x 19 in. x 12 in. rack space close to the transmission line protective relaying that utilizes fiber optics communication to accommodate a fiber optic cable distribution box. CenterPoint Energy will provide and install the fiber optic cable distribution box.
- 11.11.3.5. In cases where railroad tracks exist between the substation and the first CenterPoint Energy transmission structure outside of the substation, CenterPoint Energy will give site-specific requirements.
- 11.11.3.6. Customer shall submit drawings and other documents as necessary showing the raceway routing and construction details of the conduit according to Article 14 of this specification.
- 11.11.3.7. Actual designs shall be reviewed by CenterPoint Energy before construction starts.

**12. REMOTE TELEMETRY**

- 12.1. For remote telemetry requirements (i.e., SCADA), refer to CenterPoint Energy 007-400-02 Specification for Remote Telemetry of a Customer-Owned Facility.

**13. GENERATION**

- 13.1. Customers desiring to install and/or operate generation rated 1 MW or larger shall follow the Generation Interconnection or Modification Process (<http://www.ercot.com>). Generators shall comply with ERCOT Nodal Operating Guides and Protocols, ERCOT Planning Guides, and CenterPoint Energy engineering specifications and requirements.
- 13.2. CenterPoint Energy will construct new interconnection facilities or expand existing interconnection facilities depending on space and reliability need to serve as the Point of Interconnection Bus (POIB) for the customer as per the signed Standard Generation Interconnection Agreement (SGIA). Substation interconnecting facilities shall be in "breaker-and-a-half" or "ring" configuration and will be determined based on reliability need. If generation will be interconnected to existing facilities not entirely owned or operated by CenterPoint Energy, additional engineering and operational criteria will be considered to determine the feasibility.
- 13.3. For customers desiring to install and/or operate generation less than or equal to the customer's load (i.e., "self-serve"), the requirements for relay and generation/load islanding schemes are as follows:
  - 13.3.1. The customer shall be responsible for installing protective relays to ensure the customer's generators do not sustain a fault on the CenterPoint Energy transmission system. In addition,

							CENTERPOINT ENERGY HOUSTON, TX		
20	10/17/2024	Added 345kV Specification	Var	Var	JPB				
19	1/3/2024	Update to VRT in 3.5 and minor edits	Var	Var	PM	WRITTEN	4/9/74	E. C. Reid	
18	9/8/2023	Updates to various sections	Var	Var	PM	CHECKED	4/10/74	L. G. Pond	
17	9/2/2021	Update sections 4 & 11	Var	Var	GAC	APPROVED	7/17/74	C. S. Kayser	
							Page 34 of 46		
NO	DATE	ITEMS REVISED	BY	CH	APP	SPECIFICATION No. 007-2231-14			

customer generation shall not keep any portion of the CenterPoint Energy transmission system energized in the event that a portion of the CenterPoint Energy transmission system along with the customer's facilities becomes isolated from the rest of the CenterPoint Energy system. The transmission customer shall be responsible for installing protective relays to ensure the customer's generation does not interfere with the automatic reclosing system associated with the CenterPoint Energy transmission system (i.e., The first automatic reclosing attempt on CenterPoint Energy transmission line will occur a minimum of one second after initial trip. See Sub-Article 3.6). CenterPoint Energy will inform the customer of required changes to the automatic reclosing system at other substations associated with the CenterPoint Energy transmission system as a result of the operation of the customer's generators in parallel with the CenterPoint Energy transmission system. CenterPoint Energy will calculate and implement all settings for customer-owned relays installed for the protection and automatic reclosing of CenterPoint Energy transmission lines and for customer-owned 138 kV relays installed to prevent back-energizing a fault on the CenterPoint Energy's system from generation installed on the low-side of customer's power transformers.

- 13.3.2. The customer shall be responsible for installing controls to synchronize the customer's generators with the CenterPoint Energy's system.
- 13.3.3. The customer shall not intentionally impose additional load on the CenterPoint Energy transmission network during an under-frequency disturbance.
- 13.3.4. Customer may island their load and generation from CenterPoint Energy transmission system in one of the following manners (Note: This does not supersede any regulatory frequency ride-through requirements):
  - 13.3.4.1. Customer may island their generation and load from the CenterPoint Energy transmission system if the frequency exceeds 61.8 Hz or goes below 57.5 Hz.
  - 13.3.4.2. Customer may island its generation and a portion of its load from the CenterPoint Energy transmission system at any frequency, provided provisions are installed to ensure that any remaining load imposed on the CenterPoint Energy transmission system is not greater than the load prior to the beginning of the disturbance.
- 13.3.5. Verification of the implementation of the above requirements shall be in accordance with Article 14 of this specification.

**14. DRAWING AND DOCUMENTATION COMPLIANCE REVIEW AND COMMENTS**

- 14.1. The following completed engineering documents shall be submitted in the order shown below for CenterPoint Energy comments, functional review, and compliance with CenterPoint Energy specifications in accordance with Sub-Articles 14.2 through 14.6 of this specification:
  - 14.1.1. Site preparation and plot plan drawings shall be submitted to CenterPoint Energy for comment. Facilities that must be shown on this drawing include the dimensions of the substation site, dead-end structure location, access roadways to substation, space around the outside of the substation, (roadways, railroad tracks, walks, pipe racks, etc.), drainage features such as culverts, ditches and detention facilities (if required). Additionally, the elevation of

							CENTERPOINT ENERGY HOUSTON, TX		
20	10/17/2024	Added 345kV Specification	Var	Var	JPB				
19	1/3/2024	Update to VRT in 3.5 and minor edits	Var	Var	PM	WRITTEN	4/9/74	E. C. Reid	
18	9/8/2023	Updates to various sections	Var	Var	PM	CHECKED	4/10/74	L. G. Pond	
17	9/2/2021	Update sections 4 & 11	Var	Var	GAC	APPROVED	7/17/74	C. S. Kayser	
Page 35 of 46									
NO	DATE	ITEMS REVISED	BY	CH	APP	SPECIFICATION No. 007-2231-14			

the substation site should be indicated on these drawings (See Article 6 of this specification).

- 14.1.2. Relaying and metering one-line diagram of high voltage relaying and including generator protection one-line diagram for customers with parallel generation. The diagram shall indicate the maximum current transformer ratio and the current transformer tap ratio being utilized. The diagram shall indicate whether the 138 kV circuit breaker low SF6 gas pressure wiring is set to 'BLOCK TRIP' or to 'AUTO TRIP' the circuit breaker. The diagram shall indicate phase rotation.

CenterPoint Energy shall indicate incoming 138 kV transmission lines designation, power line carrier frequencies (if applicable), location and ratings of metering instrument transformers (high- side or low-side), CenterPoint Energy designations for circuit breakers, switches, power transformers, generators (if applicable) and the CenterPoint Energy assigned long name and 3-character substation identification. CenterPoint Energy will provide a bill of materials as indicated in Sub- Article 11.3 of this specification.

The drawing shall then be revised to show the information provided by CenterPoint Energy and resubmitted to the CenterPoint Energy designated representative. (See Articles 9 and 11 of this specification).

- 14.1.3. Substation plan, profile and section view drawings, including bus and bus supports with material callouts. The plan and profiles must indicate the geographical base lines, center line of dead-end structure and height of static wire and phase wire pull off on the dead-end structure with coordinates and the CenterPoint Energy circuit name and circuit number for incoming 138 kV transmission lines. Material callouts including conductor size, type, and quantity shall be provided in sufficient detail to allow for determination of the continuous and emergency substation facility ratings (See Articles 4 and 5 of this specification).
- 14.1.4. Final/complete relaying and metering one-line diagrams, including generator protection one-line diagram for customers with parallel generation.
- 14.1.5. When the interconnection agreement indicates that the customer must install equipment (i.e., motor soft start, variable frequency drive (VFD), etc.) in order to satisfy the CenterPoint Energy interconnection requirements of Sub-Article 4.88 of this specification, drawings and documentation of equipment to be installed shall be submitted for CenterPoint Energy review.
- 14.1.6. Equipment specification for all major pieces of equipment such as power transformers, 138 kV circuit breakers, surge arresters, disconnect switches, coupling capacitors and line traps. (See Articles 4 and 7 of this specification).
- 14.1.7. The foundation location plan. (See Articles 5 and 6 of this specification).
- 14.1.8. Design calculations, drawings and associated documents for the substation dead-end structures, instrument transformer stands, and foundations. These documents shall be submitted 30 days prior to the scheduled fabrication start.
- 14.1.9. AC and DC schematics of high voltage relaying, control and SCADA schemes. AC and DC panel board drawings. These drawings shall be submitted after the documents required in Sub- Article 14.1.2 of this specification have been approved.

							CENTERPOINT ENERGY HOUSTON, TX		
20	10/17/2024	Added 345kV Specification	Var	Var	JPB				
19	1/3/2024	Update to VRT in 3.5 and minor edits	Var	Var	PM	WRITTEN	4/9/74	E. C. Reid	
18	9/8/2023	Updates to various sections	Var	Var	PM	CHECKED	4/10/74	L. G. Pond	
17	9/2/2021	Update sections 4 & 11	Var	Var	GAC	APPROVED	7/17/74	C. S. Kayser	
							Page 36 of 46		
NO	DATE	ITEMS REVISED	BY	CH	APP	SPECIFICATION No. 007-2231-14			

- 14.1.10. Where low-side metering is used, as determined by CenterPoint Energy, original certified test data in PDF electronic file shall be provided to CenterPoint Energy for each metering instrument transformer installed (See Sub-Articles 9.2.1.2 of this specification).
- 14.1.11. The power transformer AC schematic, breaker schematics and BCT curves.
- 14.1.12. Power transformer and 138 kV circuit breaker nameplate drawings, line trap instruction book and drawings and line tuner instruction book and drawings.
- 14.1.13. Relaying, control and SCADA bill of materials. These documents shall be submitted after the documents required in Sub-Article 14.1.4 of this specification have been approved.
- 14.1.14. Cable and conduit list and routing layout.
- 14.1.15. Front and Back View of high voltage relay and control panels including interconnections.
- 14.1.16. Substation control cubicle layout drawing. (See Article 8 of this specification).
- 14.1.17. Detail (point-to-point) wiring diagrams shall be submitted, not for approval, but for use in accordance with Article 11 of this specification.
- 14.1.18. The customer calculated relay settings for the 138 kV bus and 138 kV transformer protective relay schemes and 138 kV circuit breaker failure relaying.
- 14.2. A PDF electronic file of each of the drawings indicated in Sub-Article 14.1 of this specification shall be sent, for review/comments, to the CenterPoint Energy designated representative unless a different format is specifically requested by CenterPoint Energy. Certain types of engineering documents depend upon finalization of other documents. For example, relay panel drawings cannot be prepared until the relaying AC and DC schematics are finalized. Therefore, engineering documents shall be submitted for CenterPoint Energy comments or approval in the proper sequence.
- 14.3. Customer drawings should be 100% complete when given to CenterPoint Energy to review. If a functional review cannot be done, CenterPoint Energy shall comment on compliance with CenterPoint Energy specifications and return to customer. The drawings shall then be resubmitted with CenterPoint Energy comments incorporated when 100% complete. The customer shall then proceed with drawing submittal in accordance with Sub-Article 14.4 of this specification.
- 14.4. Customer drawings that are 100% complete and marked "For Approval" shall be functionally reviewed by CenterPoint Energy for compliance with CenterPoint Energy specifications. If additional comments are made by CenterPoint Energy on the 100% complete drawings, the customer may:
  - 14.4.1. Incorporate the CenterPoint Energy comments and resubmit these drawings for further review of compliance with CenterPoint Energy specifications, or
  - 14.4.2. Notify the CenterPoint Energy designated representative acknowledging that CenterPoint Energy comments were received and shall be incorporated into the "For Construction" drawings.

							CENTERPOINT ENERGY HOUSTON, TX		
20	10/17/2024	Added 345kV Specification	Var	Var	JPB				
19	1/3/2024	Update to VRT in 3.5 and minor edits	Var	Var	PM	WRITTEN	4/9/74	E. C. Reid	
18	9/8/2023	Updates to various sections	Var	Var	PM	CHECKED	4/10/74	L. G. Pond	
17	9/2/2021	Update sections 4 & 11	Var	Var	GAC	APPROVED	7/17/74	C. S. Kayser	
							Page 37 of 46		
NO	DATE	ITEMS REVISED	BY	CH	APP	SPECIFICATION No. 007-2231-14			

- 14.5. Should the customer disagree with comments by CenterPoint Energy, the customer shall notify the CenterPoint Energy designated representative explaining why revisions are not necessary.
- 14.6. Once all issues are resolved, the final set of drawings shall be marked "For Construction." After the substation is energized a PDF electronic file of each of the drawings indicated in Sub-Article 14.1 of this specification, "As Built" drawings of the substation shall be sent to the CenterPoint Energy designated representative within 90 days.

**15. EQUIPMENT INSTALLATION**

- 15.1. The protective enclosure around the substation including gates and grounding shall be installed in accordance with the National Electrical Safety Code (IEEE C2), IEEE 1119 and IEEE 80.
- 15.2. CenterPoint Energy shall assign a long name and a 3-character substation identification to the customer-owned substation. CenterPoint Energy shall post the long name and 3-character substation identification on the door of the substation control cubicle and on the entrance gate of the substation. The long name and/or the 3-character substation identification shall be used to identify the customer-owned substation for any communications or correspondence. The 3-character mnemonic shall be used to identify the facility in the ERCOT Operations model.
- 15.3. The customer shall install all substation equipment and make all connections, except as otherwise noted in this specification. The customer shall make all equipment installation checks required by Article 16 of this specification and shall make all required measurements and readings available to CenterPoint Energy personnel if requested.
- 15.4. CenterPoint Energy will verify that the 138 kV switches operate correctly.
- 15.5. CenterPoint Energy will have the sole responsibility for calculating relay set points, applying relay settings and "out of case" testing of the following relays:
  - 15.5.1. Transmission line relaying and tuning components of the associated power line carrier equipment communication channel.
  - 15.5.2. Relays for 138 kV transmission line automatic reclosing, and
  - 15.5.3. Relays for 138 kV breaker failure protection when specified by CenterPoint Energy.

*Note:* The appropriate operation of protective relays and control circuits by performing trip and close testing from devices of Sub-Articles 15.5.1 through 15.5.3 of this specification above shall be conducted with CenterPoint Energy present to direct and observe test (24 hr. advance notice required).
- 15.6. CenterPoint Energy will furnish locks which shall remain in series with customer locks for all 138 kV disconnect switches, substation control cubicle doors and gates(s) to and from the substation.
- 15.7. The 138 kV circuit breakers, air switches and power transformers will be assigned numbers in accordance with CenterPoint Energy dispatching numbers. The numbers are to be shown on the one-line diagram and shall be marked on the circuit breaker tanks, switch handles and power transformers.

							CENTERPOINT ENERGY HOUSTON, TX		
20	10/17/2024	Added 345kV Specification	Var	Var	JPB				
19	1/3/2024	Update to VRT in 3.5 and minor edits	Var	Var	PM	WRITTEN	4/9/74	E. C. Reid	
18	9/8/2023	Updates to various sections	Var	Var	PM	CHECKED	4/10/74	L. G. Pond	
17	9/2/2021	Update sections 4 & 11	Var	Var	GAC	APPROVED	7/17/74	C. S. Kayser	
							Page 38 of 46		
NO	DATE	ITEMS REVISED	BY	CH	APP	SPECIFICATION No. 007-2231-14			

15.8. CenterPoint Energy will coordinate and provide the procedures for energizing the customer-owned substation 138 kV equipment.

**16. REQUIRED TESTS AND INSPECTIONS**

16.1. During installation but prior to energizing the equipment, the customer shall perform the following tests and inspections. CenterPoint Energy will observe the tests below that are marked with an asterisk (\*).

16.1.1. Diagnostic testing (e.g., insulation power factor (“Doble testing”, etc.), insulation resistance (“Megger”, etc.) of all equipment (e.g., arresters, coupling capacitors, etc.), including all tests as specified by manufacturer.

16.1.2. The required tests and inspections for control cables and panels are as follows:

16.1.2.1. Check continuity and perform insulation resistance test conductor-to-ground and conductor-to-conductor.

16.1.2.2. Perform a point-to-point wiring check of protective relaying and control panels.

16.1.2.3. Verify protective relaying control circuits by performing functional trip and close testing.

16.1.2.4. Inject current from current transformers through relays.\*

16.1.2.5. CenterPoint Energy personnel will calculate the set points, apply the settings and test the multi-function transmission line protection relays after the customer has completed point-to-point wiring checks of protective relaying and control panels and verified protective relaying control circuits by performing functional trip and close testing.

16.1.3. The required tests and inspections for power cables are as follows:

16.1.3.1. Check continuity and phasing sequence.

16.1.3.2. Perform insulation resistance test of cables.

16.1.3.3. High-pot.

16.1.4. The required tests and inspections for circuit breakers are as follows:

16.1.4.1. Inspect and adjust main auxiliary switch assembly per manufacturer’s instructions.

16.1.4.2. Inspect, adjust, and lubricate operating mechanism per manufacturer’s instructions.

16.1.4.3. Ratio check, excitation test, insulation resistance test, and polarity on all current transformers. Leave un-used current transformers shorted and grounded on secondary terminals.

							CENTERPOINT ENERGY HOUSTON, TX		
20	10/17/2024	Added 345kV Specification	Var	Var	JPB				
19	1/3/2024	Update to VRT in 3.5 and minor edits	Var	Var	PM	WRITTEN	4/9/74	E. C. Reid	
18	9/8/2023	Updates to various sections	Var	Var	PM	CHECKED	4/10/74	L. G. Pond	
17	9/2/2021	Update sections 4 & 11	Var	Var	GAC	APPROVED	7/17/74	C. S. Kayser	
							Page 39 of 46		
NO	DATE	ITEMS REVISED	BY	CH	APP	SPECIFICATION No. 007-2231-1.1			

- 16.1.4.4. Check resistance of close, trip and trip free coils.
- 16.1.4.5. Perform insulation resistance test of main contact assembly and bushings. Measure main contact resistance ("Ductor").
- 16.1.4.6. Make dielectric insulation and power factor tests on main contact assembly and bushings.
- 16.1.4.7. Perform insulation resistance test of control circuits conductor-to-ground and conductor-to-conductor.
- 16.1.4.8. Record all measurements and readings.
- 16.1.4.9. Make time-travel recordings to verify proper opening speed.
- 16.1.5. The required tests and inspections for disconnects and switches are as follows:
  - 16.1.5.1. Check and adjust contact alignment and wipe.
  - 16.1.5.2. Adjust operating linkage to obtain full open and close positions and tighten all clamps and set screws.
  - 16.1.5.3. Check and tighten all electrical connections.
  - 16.1.5.4. Lubricate linkage and bearings, if required.
  - 16.1.5.5. Clean all grease from contacts.
- 16.1.6. The required tests and inspections for batteries and charger are as follows:
  - 16.1.6.1. Assemble batteries per manufacturer's instructions.
  - 16.1.6.2. Coat all connections on battery terminals with no-oxide grease.
  - 16.1.6.3. Install, connect, and adjust charger per manufacturer's instructions.
  - 16.1.6.4. Put batteries on equalize charge until the specific gravity of all cells is within the limits set by manufacturer.
  - 16.1.6.5. Read and record the float voltage and specific gravity of each cell.

**17. RECOMMENDED TESTS AND INSPECTIONS**

17.1. During installation but prior to energizing the equipment, CenterPoint Energy recommends that the customer perform the following tests and inspections, as a minimum. This list is not considered to be exhaustive or all-inclusive.

						CENTERPOINT ENERGY HOUSTON, TX		
20	10/17/2024	Added 345kV Specification	Var	Var	JPB			
19	1/3/2024	Update to VRT in 3.5 and minor edits	Var	Var	PM	WRITTEN	4/9/74	E. C. Reid
18	9/8/2023	Updates to various sections	Var	Var	PM	CHECKED	4/10/74	L. G. Pond
17	9/2/2021	Update sections 4 & 11	Var	Var	GAC	APPROVED	7/17/74	C. S. Kayser
						Page 40 of 46		
NO	DATE	ITEMS REVISED	BY	CH	APP	SPECIFICATION No. 007-2231-1.1		

17.1.1. For low-side equipment, test relays, check transformer and bus automatic reclosing and check operations indicators when tripping through the panel with current.

Note: CenterPoint Energy will calculate and implement all settings for customer-owned relays installed for the protection and automatic reclosing of CNP transmission lines and for customer-owned 138 kV relays installed to prevent back-energizing CNP's system from generation installed on the low-side of customer power transformers. On a case-by-case basis, CNP may issue settings for other customer-owned relays.

17.1.2. The recommended tests and inspections for all substation equipment are as follows:

17.1.2.1. Clean rusted surfaces, prime all bare metal surfaces, and touch up with paint matching the finish coat.

17.1.3. The recommended tests and inspections for control work are as follows:

17.1.3.1. Wire check all cables to current transformers and perform insulation resistance test of cables.

17.1.3.2. In the following order:

- 17.1.3.2.1. Polarity check current transformers.
- 17.1.3.2.2. Ratio check current transformers.
- 17.1.3.2.3. Excitation test current transformers.
- 17.1.3.2.4. Insulation resistance test current transformers.

17.1.3.3. Check cable connections to panels.

17.1.3.4. Wires check panels.

17.1.4. The recommended tests and inspections for switchgear are as follows:

- 17.1.4.1. Check all bolted bus connections.
- 17.1.4.2. High-pot cable with 25 kV DC.
- 17.1.4.3. Ensure that all exposed bus work is properly insulated.
- 17.1.4.4. Bridge all bus work.
- 17.1.4.5. Perform dielectric insulation and power factor tests on all bus work.
- 17.1.4.6. Check breaker-lifting devices for alignment and adjust limit switches, if necessary.
- 17.1.4.7. Adjust auxiliary and cell switches.

							CENTERPOINT ENERGY HOUSTON, TX		
20	10/17/2024	Added 345kV Specification	Var	Var	JPB				
19	1/3/2024	Update to VRT in 3.5 and minor edits	Var	Var	PM	WRITTEN	4/9/74	E. C. Reid	
18	9/8/2023	Updates to various sections	Var	Var	PM	CHECKED	4/10/74	L. G. Pond	
17	9/2/2021	Update sections 4 & 11	Var	Var	GAC	APPROVED	7/17/74	C. S. Kayser	
							Page 41 of 46		
NO	DATE	ITEMS REVISED	BY	CH	APP	SPECIFICATION No. 007-2231-14			



17.1.4.8. Check continuity for all AC, DC control, and current transformer circuits.

17.1.5. The recommended tests and inspections for transformers are as follows:

- 17.1.5.1. Visually inspect for internal shipping damage and check all internal connections.
- 17.1.5.2. Install bushing and accessories per manufacturer's instructions.
- 17.1.5.3. Inspect load tap changer (LTC) compartment and adjust per manufacturer's instruction and check LTC operation, if applicable.
- 17.1.5.4. Bridge primary and secondary windings on all tap positions and a final check on the tap position that will be used.
- 17.1.5.5. Ratio check, excitation test, perform insulation resistance test, and check polarity on all current transformers. Leave unused current transformers shorted and grounded on the secondary.
- 17.1.5.6. Vacuum fill per manufacturer's instructions.
- 17.1.5.7. Check for oil and gas leaks. (This may be done prior to vacuum filling).
- 17.1.5.8. Test oil before and after filling. (Maximum power factor, minimum dielectric strength, color, acidity, and interfacial tension).
- 17.1.5.9. Test oil for dissolved combustible gas and moisture content (Note: This test is to be performed 24 to 48 hours after the substation has been energized).
- 17.1.5.10. Check voltage regulating relay and controls.
- 17.1.5.11. Check cooling equipment and controls.
- 17.1.5.12. Check nitrogen-regulating equipment and adjust per manufacturer's instructions.
- 17.1.5.13. Check sudden pressure relay and associated circuits.
- 17.1.5.14. Check and connect desired alarm circuits.
- 17.1.5.15. Perform insulation resistance test and insulation power factor test of bushing and windings (e.g., "Doble testing").
- 17.1.5.16. Check all bushings to bus connections.
- 17.1.5.17. Check all current transformers and control circuit connections.
- 17.1.5.18. Record all measurements and readings.
- 17.1.5.19. Check core ground.

							CENTERPOINT ENERGY HOUSTON, TX		
20	10/17/2024	Added 345kV Specification	Var	Var	JPB				
19	1/3/2024	Update to VRT in 3.5 and minor edits	Var	Var	PM	WRITTEN	4/9/74	E. C. Reid	
18	9/8/2023	Updates to various sections	Var	Var	PM	CHECKED	4/10/74	L. G. Pond	
17	9/2/2021	Update sections 4 & 11	Var	Var	GAC	APPROVED	7/17/74	C. S. Kayser	
							Page 42 of 46		
NO	DATE	ITEMS REVISED	BY	CH	APP	SPECIFICATION No. 007-2231-14			

18. REFERENCE DRAWINGS

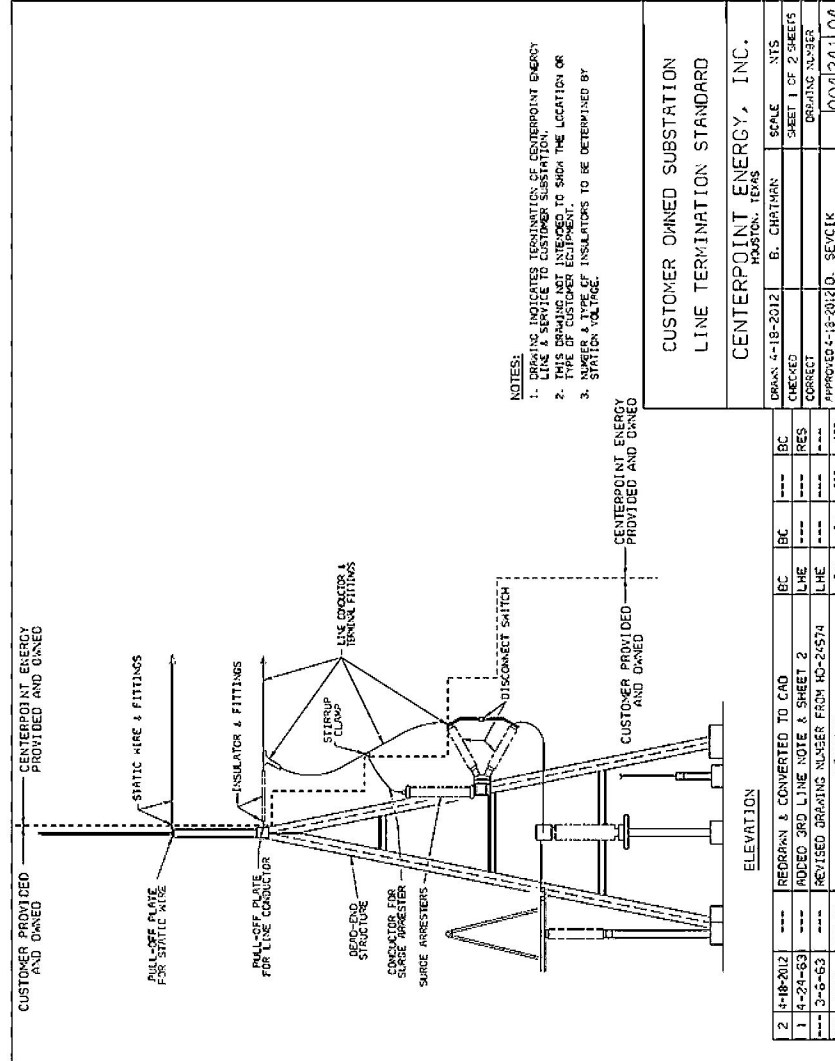

CENTERPOINT ENERGY HOUSTON, TX							
20	10/17/2024	Added 345kV Specification	Var	Var	JPB		
19	1/3/2024	Update to VRT in 3.5 and minor edits	Var	Var	PM	WRITTEN	4/9/74 E. C. Reid
18	9/8/2023	Updates to various sections	Var	Var	PM	CHECKED	4/10/74 L. G. Pond
17	9/2/2021	Update sections 4 & 11	Var	Var	GAC	APPROVED	7/17/74 C. S. Kayser
NO	DATE	ITEMS REVISED	BY	CH	APP	Page 43 of 46 SPECIFICATION No. 007-2231-14	

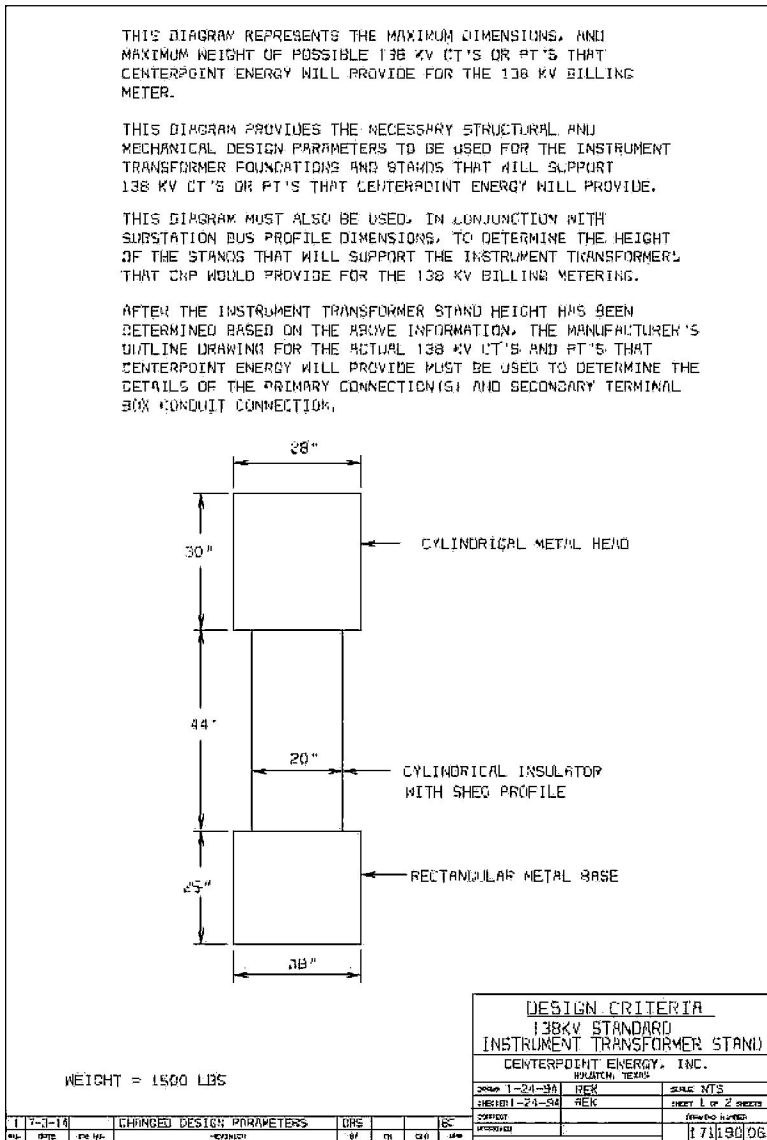

						CENTERPOINT ENERGY HOUSTON, TX		
20	10/17/2024	Added 345kV Specification	Var	Var	JPB			
19	1/3/2024	Update to VRT in 3.5 and minor edits	Var	Var	PM	WRITTEN	4/9/24	E. C. Reid
18	9/8/2023	Updates to various sections	Var	Var	PM	CHECKED	4/10/24	L. G. Pond
17	9/2/2021	Update sections 4 & 11	Var	Var	GAC	APPROVED	7/17/24	C. S. Kayser
						Page 44 of 46		
NO	DATE	ITEMS REVISD	BY	CH	APP	SPECIFICATION No. 007-2231-14		

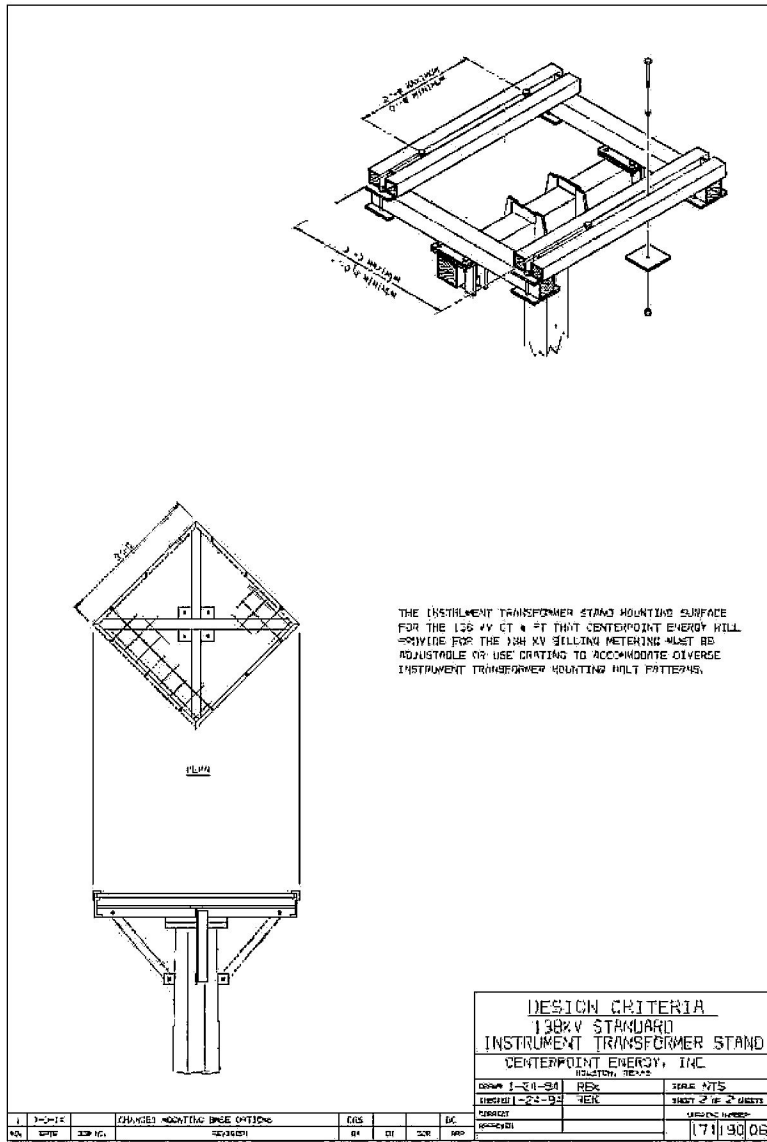

CENTERPOINT ENERGY HOUSTON, TX						
20	10/17/2024	Added 345kV Specification	Var	Var	JPB	
19	1/3/2024	Update to VRT in 3.5 and minor edits	Var	Var	PM	WRITTEN 4/9/24 E. C. Reid
18	9/8/2023	Updates to various sections	Var	Var	PM	CHECKED 4/10/24 L. G. Pond
17	9/2/2021	Update sections 4 & 11	Var	Var	GAC	APPROVED 7/17/24 C. S. Kayser
Page 45 of 46						
NO	DATE	ITEMS REVISED	BY	CH	APP	SPECIFICATION No. 007-2231-14

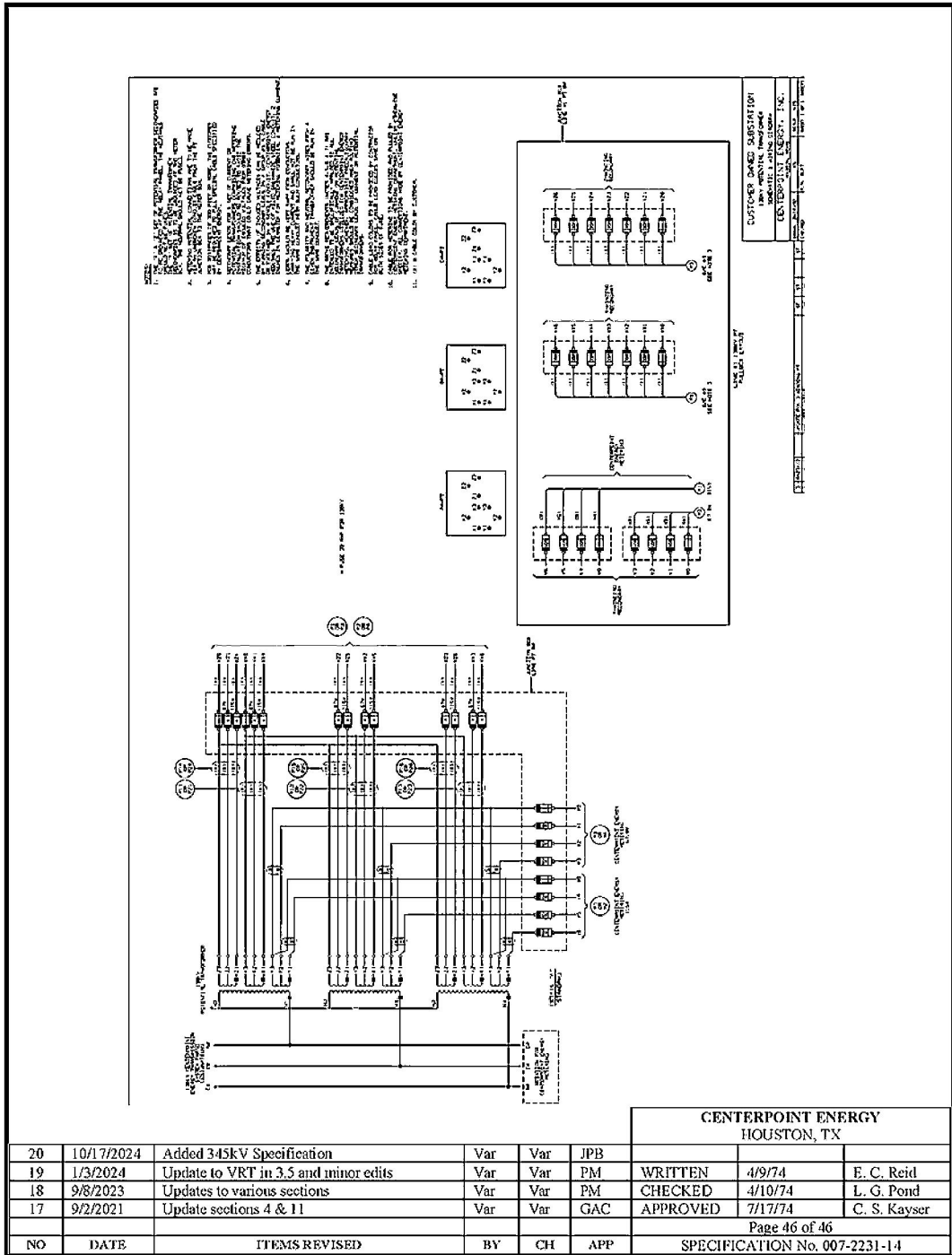

**Exhibit “J”**  
**Minimum acceptable electrical, mechanical, and structural  
design characteristics for 345 kV interconnection substation  
construction**

Not Applicable

## **Exhibit “K” Subtractive Metering Guideline**

### **1. SCOPE**

- 1.1. This guideline defines the requirements for Subtractive Metering through a Customer-owned facility.
- 1.2. Subtractive Metering is defined as any TDSP metering (including WSL/EPS/Revenue) located in the Customer facility, below the Point of Interconnection (POI) or Point of Delivery (POD).
  - 1.2.1 CenterPoint Energy may determine and communicate to the Customer that specific TDSP metering, located in the customer facility and located at the POI or POD, shall be defined as Subtractive Metering.

### **2. GENERAL**

- 2.1. The metered service may require a signed Tariff Form: – Agreement for Subtractive Metering.
- 2.2. A load analysis and a completed engineering one-line diagram, fully detailing all of the Customer’s equipment from the POI or POD down to and including all Subtractive Metering, shall be submitted to the Accounts Representative, for CenterPoint Energy comments and functional review.
- 2.3. The Subtractive Metering shall not be configured such that bi-directional power flow must be accounted for by the Subtractive Metering unless the Subtractive Metering is located at the POI or POD.
- 2.4. The Subtractive Metering current transformers (CTs) shall only be summed when the following conditions are met.
  - 2.4.1. The summation of CTs shall not exceed a maximum of two sets (either two-phase or three-phase sets), and
  - 2.4.2. The summed CTs shall not be separated by a bus tie breaker or other method of source isolation.
- 2.5. The Subtractive Metering potential transformers (PTs) shall not incorporate a potential rollover or alternate source design.
- 2.6. The metered service is allowed only one voltage transformation from the POI or POD service voltage (i.e., 345kV/138kV, 138kV/12kV).
- 2.7. CenterPoint Energy shall specify all instrument transformers used for CenterPoint Energy metering. All equipment, engineering and installation shall be furnished by the Customer unless otherwise noted in this guideline.

2.8. The customer shall furnish three phase-to-neutral PTs per meter point and three-phase CT sets when the source to the meter point is capable of supplying a three-phase, four-wire system.

2.9. The customer may furnish two phase-to-phase PTs per meter point and two-phase CT sets when the source to the meter point is capable of supplying a three-phase, three-wire system. No more than two power transformers shall be directly connected to the load side of a two-phase, two-element, delta meter point.

2.10. All equipment and work covered by this guideline shall be designed, constructed, and tested in accordance with the latest revisions or editions of industry requirements in effect at the time of fabrication. Industry requirements include the applicable codes, standards, specifications, regulations, tests, and procedures of all federal, state and local laws, including but not limited to the following:

- 2.10.1. American National Standards Institute (ANSI)
- 2.10.2. IEEE formerly the Institute of Electrical and Electronics Engineers, Inc.
- 2.10.3. National Electrical Manufacturers Association (NEMA)
- 2.10.4. Occupational Safety and Health Administration (OSHA)
- 2.10.5. Federal Communications Commission (FCC)
- 2.10.6. NFPA 70 - National Electric Code.

2.11. In the event of conflicting requirements, this guideline shall take precedence.

2.12. CenterPoint Energy requires access to the subtractive meters 7 days-a-week, 24 hours-a-day, 365 days-a- year. Site access, site operating procedures and road access by CenterPoint Energy personnel should be considered when determining the subtractive metering location.

**3. DESIGN, LAYOUT, AND PHYSICAL CRITERIA**

3.1. Customer shall install metering and communications cabinets per the attached Figure 1. Each metering cabinet is 30 inches wide, 42 inches high, 12 inches deep and each communication cabinet is 24 inches wide, 24 inches high and 18 inches deep and both are wall mounted. Wall space 3.0 ft. wide and 8.0 ft. high measured from the floor with 4.0 ft. (from wall) front clearance shall be provided for installation of each cabinet. Cabinets will be provided by CenterPoint Energy and shall be installed by customer 36” above floor. See CNP Service Standards Book for Company Offices for pickup of equipment. The meters will be owned and maintained by CNP.

3.2. Metering and communication cabinets shall be located inside an environmentally controlled cubicle.



3.3. Any part of the metering system that is installed by the customer or its agent shall conform to ANSI C12.1 at minimum.

3.4. Customers requesting KYZ pulses shall provide all conduits and wiring necessary to connect to a junction box provided by CenterPoint Energy and mounted on the metering installation.

3.5. The Customer shall provide a 120 VAC, fifteen (15) amp, dedicated AC power circuit, protected by a fifteen (15) amp circuit breaker, to the Metering cabinet.

3.6. The Customer shall provide a 130 VDC, fifteen (15) amp, dedicated DC power circuit, protected by a fifteen (15) amp circuit breaker, to the Metering Cabinet.

3.7. All metering conduits shall be designed and installed in accordance with Section 9 of the Customer- Owned 138kV Substation Design Specification. All metering conduits shall be Rigid Galvanized Steel (RGS) unless otherwise detailed in the Customer-Owned 138kV Substation Design Specification.

3.8. CenterPoint Energy personnel shall supply control cable and make all secondary instrument transformers connections. The customer is responsible for pulling the CenterPoint Energy provided control cable.

#### **4. COMMUNICATION LINES**

4.1. The Customer shall provide and maintain fiber optic cable from the POI or POI meter to the CNP subtractive metering communications cabinet.

4.2. Customer shall provide 3/4" antenna conduit from metering cabinet to outer wall of control cubicle.

#### **5. CURRENT TRANSFORMERS AND POTENTIAL TRANSFORMERS**

5.1. Instrument Transformers shall be delivered to CenterPoint Energy for testing along with the original certified test reports prior to installation by customer. (Contact Customer Rep. for Details)

5.2. The Instrument Transformers shall be individual, single-phase CTs and PTs; combined units are not acceptable.

5.3. The CTs shall be at a minimum 0.15% accuracy rating with 1.8 Ohm burden rating (IEEE C57.13, 0.15B1.8).

5.4. The PTs shall be at a minimum 0.3% accuracy rating, "Z" rating (IEEE C57.13).

5.5. A dedicated secondary winding is required for CenterPoint Energy Metering. If multiple windings are present, the “Y” winding shall be used for CenterPoint Energy metering.

5.6. PTs shall be equipped with 60 A, current limiting primary fuses.

5.7. Replacement of any CTs or PTs, if necessary, shall be the Customer’s responsibility.

**6. SWITCHGEAR MOUNTED METERING INSTRUMENT TRANSFORMERS**

6.1 The customer shall provide space for CenterPoint Energy specified instrument transformers in the customer’s switchgear.

6.2 Metering CTs shall be installed in the incoming main breaker cubicle. The CTs shall be installed by the customer.

6.3 Metering PTs shall be installed in roll-out boxes. The PTs shall be installed by the customer.

6.4 The customer is responsible for opening switchgear if requested by CenterPoint Energy personnel.

6.5 The customer shall supply copper ground wire from the customer’s switchgear to the CenterPoint Energy meter.

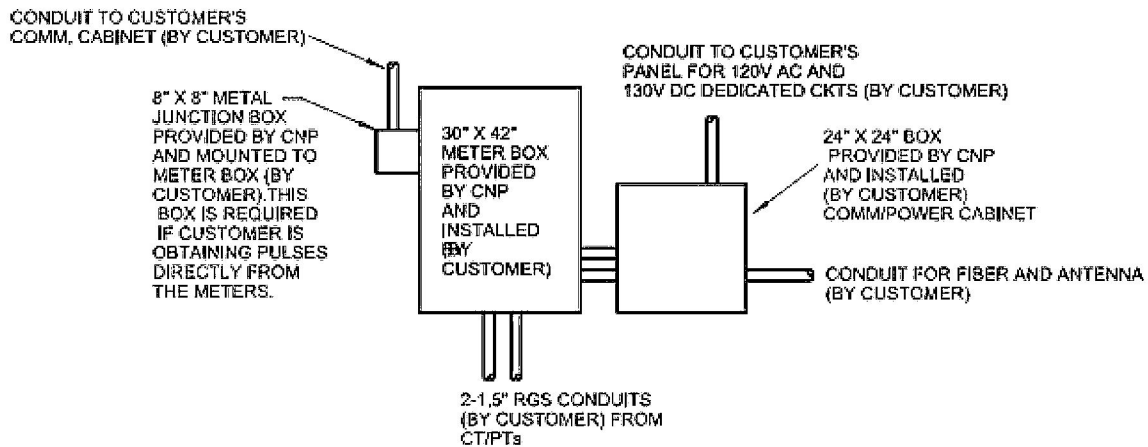

Figure 1: Control House Layout of Metering Cabinets

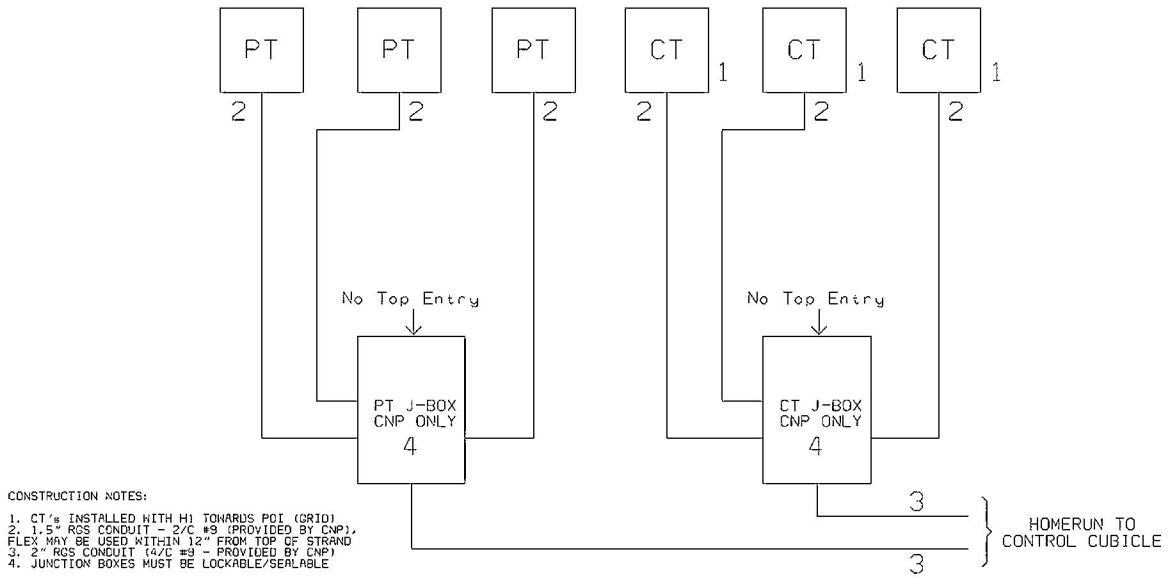

Figure 2: Junction Box Layout

**Exhibit “L”**  
**Specifications for Installation of Access Roads, Paving, and**  
**Drainage**

# CENTERPOINT ENERGY

## SPECIFICATION FOR

### INSTALLATION OF ACCESS ROADS, PAVING AND DRAINAGE

**HIGH VOLTAGE CIVIL DESIGN DEPARTMENT  
1111 LOUISIANA ST HOUSTON, TEXAS 77251**

#### 2022 Version

**REFERENCE DRAWINGS:**

CONSTRUCTION DRAWINGS

**REFERENCE SPECIFICATIONS:**

EXHIBIT A - PRIMARY ACCESS ROAD DETAIL

**LOCATION OF WORK:**

(Insert Substation Name & Address)

						CNP HOUSTON, TEXAS			
						WRITTEN	D. Tamez		
						CHECKED			
						APPROVED			
						Page 1 of 6			
No.	DATE	ITEMS REVISED	BY	CH	APP		007	229	X

1.0 SCOPE

- 1.1 This specification covers the design criteria, material specifications, and construction methods for the installation of flexible base roads and drainage on CenterPoint Energy's (CNP) projects.

2.0 ACCESS ROAD DESIGN CRITERIA

- 2.1 The Generator shall design a 24-foot-wide access road with a maximum 1% slope or as designated by CNP representative. Refer to Exhibit A, "Primary Access Road" cross-section detail.
- 2.2 Minimum turning radius of 60 degrees shall be provided for all turns. 90-degree turns shall be avoided, if possible.
- 2.3 Base material shall be designed to a minimum depth of 8 inches.
- 2.4 Subgrade treatment shall be specified to a minimum depth of 6 inches.
- 2.5 Minimum 5-foot-wide shoulders shall be provided on both side of the road or as designated by CNP representative.
- 2.6 Generator shall exhaust all reasonable options to avoid locating access road inside a delineated FEMA floodplain or flood zones determined by hydrology study performed by Generator.
- 2.7 If locating road inside floodplain is inevitable, access road grading elevations shall be designed to avoid flooding during heavy rain events.
- 2.8 Access roads shall be all-weather roads and shall maintain 24/7 access to CNP facilities during storm events.
- 2.9 An electronic copy and georeferenced CAD files of the "Plan and Profile" drawings shall be submitted to CNP representative for review and approval prior to construction.
- 2.10 Generator shall coordinate with CNP representative the grading elevations of sections of the road connecting to CNP facilities.
- 2.11 Drawings shall be designed and stamped by a Professional Engineer with a license in the state of Texas.

3.0 GENERAL

- 3.1 The paving work shall be done in accordance with the CNP approved drawings, this specification and any drawings or specifications provided by CNP's designated representative for a specific project.
- 3.2 In case of a conflict, the order of precedence shall be the directions given by CNP's representative, this specification, and the CNP drawings.
- 3.3 The Generator shall maintain on the job site a complete and readable set of all specifications and any drawings approved by CNP.
- 3.4 No deviation from this specification will be permitted without authorization from the CNP representative.

4.0 GRUBBING AND EXCAVATION

- 4.1 The area to be paved shall be cleared and grubbed to a minimum depth of 4 (four) inches. All stumps, logs, brush, roots, vegetation, rubbish, designated trees, and other objectionable material shall be removed and disposed of offsite.

- 4.2 Soft or unstable materials that are deemed unfit to meet compaction requirements shall be removed as directed by CNP representative and replaced with an approved fill material.
- 4.3 All holes, ruts, and depressions shall be filled with material approved by the CNP representative.
- 4.4 Excavated material shall not be used as fill without specific authorization of the CNP representative and prior geotechnical studies.
- 4.5 The Generator shall exercise care when grubbing and/or excavating, to stay clear of power lines, structures, pipe, septic tanks, fences, grounding mats or any underground facility installed before the start of construction.
- 4.6 The Generator shall reimburse CNP for the repair or replacement of any previously identified facilities he damages.

5.0 SELECT FILL MATERIAL

5.1 TYPE A FILL MATERIAL

5.1.1 TYPE A fill material shall conform to CL or SM soil classification as designated in ASTM D-2487. Atterberg Limits for TYPE A material shall be as follows:

Liquid Limit	30 – 45
Plasticity Index	7 – 15

5.2 TYPE B FILL MATERIAL

5.2.1 TYPE B fill material shall conform to a CL or SM soil classification as designated in ASTM D-2487. Atterberg Limits for TYPE B material shall be as follows:

Maximum Liquid Limit	45
Maximum Plasticity Index	20

6.0 CEMENT STABILIZED SOIL

- 6.1 Soil stabilization with cement shall be done in accordance with the State Department of Highways and Public Transportation (SDHPT) 1982 Standard Specifications for Construction of Highways, Streets, and Bridges – Item 270.
- 6.2 The cement shall be Type 1 of a standard brand of Portland cement and shall conform to the requirements of ASTM – C150.
- 6.3 The subgrade conditions shall be approved by the CNP representative prior to the application of cement.
- 6.4 The soil to be cement stabilized shall be limited to the designated area and depth shown on the approved drawings or as designated by the CNP representative.
- 6.5 Upon completion of final compaction, the stabilized soil shall be cured for a minimum of 24 hours prior to the placement of fill or base materials.
- 6.6 CNP or a Geotechnical representative will specify the amount of Portland cement to be utilized as required by the soil conditions.
- 6.7 The Generator shall assume responsibility for damages resulting from cement that has washed or blown off the subgrade.

7.0 LIME STABILIZED SOIL

- 7.1 Soil stabilization with lime shall be done in accordance with SDHPT Items 260 and 264, and the 10/91 Special Provision to Item 260, and the 12/87 Special Provision to Item 264.
- 7.2 The subgrade conditions shall be approved by the CNP representative prior to the application of lime.
- 7.3 The lime shall be furnished in a slurry form (Type B, Commercial Lime Slurry) or (pellet) pebbilized form (Type C, Quicklime, Grade DS).
- 7.4 The soil to be lime stabilized shall be limited to the designated area and depth shown on the approved drawings or as designated by the CNP representative.
- 7.5 CNP or a Geotechnical representative will specify the amount of lime to be utilized as required by the soil conditions.
- 7.6 The Generator shall assume full responsibility for damages resulting from lime that has washed or blown off the subgrade.

8.0 BASE MATERIALS

- 8.1 The base material used for the surface course shall be limestone and/or cement stabilized limestone and conform to SDHPT Items 247 and 274 respectively.

8.2 LIMESTONE

8.2.1 The aggregate used for yard paving shall conform to the following size requirements:

AGGREGATE TYPE	U.S. STANDARD SIEVE SIZE	PERCENT RETAINED BY WEIGHT	MAX. LIQUID LIMIT	MAX. PLASTIC LIMIT
Limestone (Type A, Grade 1)	1 3/4" Sieve	0		
	7/8" Sieve	10 - 35		
	3/8" Sieve	30 - 50		
	No. 4 Sieve	45 - 65		
	No. 40 Sieve	70 - 85	35	10

WET BALL

Maximum Amount ..... 40%  
 Increase Passing No. 40 ..... 20%

8.3 CEMENT STABILIZED LIMESTONE

8.3.1 The aggregate used for road paving shall conform to the following size requirements:

AGGREGATE TYPE	U.S. STANDARD SIEVE SIZE	PERCENT RETAINED BY WEIGHT	MAX. LIQUID LIMIT	MAX. PLASTIC LIMIT
Limestone (Type A, Grade 1)	1 3/4" Sieve	0		
	7/8" Sieve	10 - 35		
	3/8" Sieve	30 - 50		
	No. 4 Sieve	45 - 65		
	No. 40 Sieve	70 - 85	35	10



- 8.3.2 The cement content shall be 5% by dry weight and the minimum compressive strength shall be 650 psi at 7 days.
- 8.3.3 The cement shall be Type 1 of a standard brand of Portland cement and shall conform to the requirements of ASTM – C150.
- 8.3.4 The cement stabilized base courses shall not be mixed or placed when the air temperature is 40 degrees Fahrenheit (or below) and falling. The material may be placed if the air temperature is 35 degrees Fahrenheit and rising.
- 8.4 The aggregate shall be free from excess salt, alkali, vegetable matter, clay, or otherwise objectionable matter.

9.0 COMPACTION

- 9.1 Select fill shall be compacted in lifts not to exceed eight (8) inches.
- 9.2 The subgrade or subbase shall be “proof rolled” prior to the placement of paving materials.
- 9.3 All select fill materials, scrubber base, stabilized soil, existing flexible base paving, and excavated areas shall be compacted to 95% of the maximum density established by the Standard Proctor Density Test, ASTM D-698, with a moisture content within –2% or +3% of optimum.
- 9.4 At the discretion of the CNP representative, in-place density testing will be performed.

10.0 CONCRETE PIPE

- 10.1 All storm sewer piping and culverts shall be reinforced concrete, manufactured to comply with ASTM C-76, Class III, Wall B, or equivalent corrugated plastic pipe approved by Texas Department of Highways.

11.0 GRADING

- 11.1 The Generator shall surface grade the access road as shown on the approved drawings or as directed by the CNP representative to provide a smooth finish and good positive drainage.
- 11.2 When grading, it shall be the Generator’s responsibility to stay clear of power lines and structures. Care shall be taken to avoid damage to any existing pipelines, septic tanks, telephone lines, etc. If these structures are damaged due to the Generator’s negligence, they shall be repaired or replaced at his expense.
- 11.3 All unpaved areas shall be surface graded as necessary to provide a smooth surface for proper drainage, and to allow mowing.

12.0 CONSTRUCTION METHODS

- 12.1 12.1 The Generator shall install limestone base material to a maximum depth of 0.8 ft, and cement stabilized limestone to a maximum depth of 0.8 ft, unless otherwise directed by the drawings or the CNP representative. However, in no case shall the base material be placed in lifts greater than 0.5 ft or less than 0.25 ft.
- 12.2 The subgrade shall be graded and compacted prior to placement of base materials. All weak spots shall be corrected with a suitable material.

- 12.3 The base material shall be installed on a dry, uniformly compacted subgrade.
- 12.4 The finished shape of the base course shall be smooth and conform to the established lines and grades shown on the approved drawings or as directed by the CNP representative.
- 12.5 During compaction the Generator shall use a vibratory plate compactor when within five (5) feet of any structure or in areas determined by CNP to be hazardous due to electrical clearances or crowded conditions.
- 12.6 Self-propelled vibratory rollers are prohibited within twenty (20) feet of any electrical structure.
- 12.7 All paving areas with “nests” of segregated coarse or fine material shall be corrected by scarifying or removing and replacing with a well-graded material. The material shall be placed and compacted to meet the requirements as stated in Section 9.0 of this specification.
- 12.8 The stabilized base shall be compacted to a density of not less than 95% of the maximum density established by the Standard Proctor Density Test ASTM D-689. After completion of compaction, the surface that forms the road and ramp paving shall be thoroughly wetted.
- 12.9 Prior to each day’s construction, a straight joint shall be formed by cutting back into the entire depth of the previously placed material to form a true vertical face, free of loose and shattered materials.
- 12.10 Not more than one (1) hour shall elapse from the time the cement stabilized limestone arrives on site and the compaction begins.
- 12.11 The compaction of cement stabilized limestone shall be completed within three (3) hours of the time water is added to the mixture.
- 12.12 The cement stabilized limestone shall be protected against rapid drying for a period of 72 hours.
- 12.13 The CNP representative may at his discretion reject any base material that he deems is not in accordance with the requirements of this specification.
- 12.14 The Generator shall erect and maintain sufficient barricades to prevent traffic on newly paved area(s) for a period of 72 hours or as directed by the CNP representative.

# EXHIBIT A

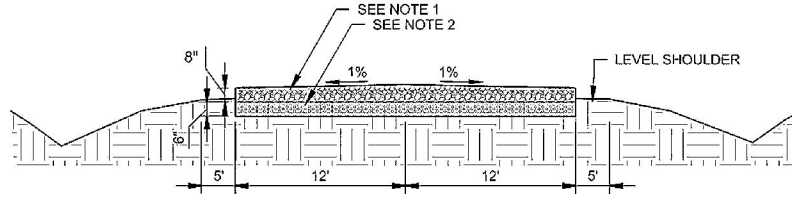

**NOTES:**

1. **BASE MATERIAL** - BASE MATERIAL SHOULD BE COMPOSED OF CRUSHED LIMESTONE OR CRUSHED CONCRETE MEETING THE REQUIREMENTS OF TXDOT 2014 STANDARD SPECIFICATIONS ITEM 247, TYPE A , GRADE 1 . THE BASE MATERIAL SHOULD BE COMPACTED TO AT LEAST 95 PERCENT OF THE MODIFIED EFFORT (ASTM D 1557) MAXIMUM DRY DENSITY AT MOISTURE CONTENT WITHIN 2 PERCENT OF THE OPTIMUM MOISTURE CONTENT.
  
2. **LIME TREATED SUBGRADE** - WE ANTICIPATE THAT THE PAVEMENT SUBGRADE WILL GENERALLY CONSIST OF ON-SITE MEDIUM TO HIGH PLASTICITY CLAY SOILS. THE PAVEMENT SUBGRADE SHOULD BE TREATED WITH LIME IN ACCORDANCE WITH TXDOT 2014 STANDARD SPECIFICATIONS ITEM 260. BASED ON THE CLASSIFICATION TEST RESULTS, WE RECOMMEND THAT APPROXIMATELY 8 TO 10 PERCENT LIME BY DRY WEIGHT BE USED FOR ESTIMATING AND PLANNING. THE PERCENTAGES ARE GIVEN AS APPLICATION BY DRY WEIGHT AND ARE TYPICALLY EQUIVALENT TO ABOUT 40 TO 50 POUNDS OF LIME PER SQUARE YARD PER 6-INCH DEPTH. THE ACTUAL QUANTITY OF LIME SHOULD BE DETERMINED AT THE TIME OF CONSTRUCTION BASED ON LIME DETERMINATION TESTS CONDUCTED USING BULK SAMPLES OF THE SUBGRADE SOILS. THE PULVERIZATION, MIXING, AND CURING OF THE LIME TREATED SUBGRADE IS OF PARTICULAR IMPORTANCE FOR THE ON-SITE CLAY SOILS. THE SUBGRADE SHOULD BE COMPACTED TO A MINIMUM OF 95 PERCENT OF THE STANDARD EFFORT (ASTM D 698) MAXIMUM DRY DENSITY AT A MOISTURE CONTENT BETWEEN OPTIMUM AND 4 PERCENT WET OF THE OPTIMUM MOISTURE CONTENT.

