



Filing Receipt

Filing Date - 2024-04-11 05:49:04 PM

Control Number - 35077

Item Number - 1776



Thomas J. Yamin, P.E.
Director
Regulatory Transmission and Planning

April 11, 2024

Filing Clerk
Public Utility Commission of Texas
1701 N. Congress Avenue
P.O. Box 13326
Austin, TX 78711-3326

RE: Subject: Project No. 35077–Oncor Electric Delivery Company’s Transmission Contract Filing Pursuant to Subst. Rule 25.195(h)

Find attached the Amended and Restated Generation Interconnection Agreement between Oncor Electric Delivery Company LLC and Pyron Wind Farm, LLC formerly known as Airtricity Pyron Wind Farm, LLC (Pyron Wind Repower) (23INR0525), dated March 14, 2024 (Interconnection Agreement), for filing at the Public Utility Commission pursuant to Substantive Rule 25.195(h). Because the filed Interconnection Agreement contains slight deviations from the Commission-approved standard generation interconnection agreement (SGIA), Oncor Electric Delivery has prepared this letter explaining the changes and request that it be filed with the aforementioned Interconnection Agreement.

- The Interconnection Agreement has been modified to replace the term “senior secured debt” with “senior long term debt” and replace the term “Standard & Poor’s” with “Standard & Poor’s or Moody’s Investor’s Service”, “Standard & Poor’s and Moody’s Investor’s Service”, and “Standard & Poor’s and Moody’s Investor’s Service”, respectively, in Exhibit “A”, Article 9, INSURANCE, Subsection 9.1.J.
- The definition for “ISO” has been deleted and all references to “ISO” have been changed to “ERCOT”. The following language in Exhibit “A”, Article 6, Subsection 6.2, Control Area Notification has been deleted, “At least six months before Trial Operation, the Generator shall notify the TSP in writing of the Control Area in which it will be located. If the Generator elects to be located in a Control Area other than the Control Area in which the TSP is located, all necessary agreements, including but not limited to remote control area generator interchange agreements, if applicable, and appropriate measures under such agreements, shall be executed and implemented prior to the placement of the Plant in the other Control Area. The Parties will diligently cooperate with one another to enable such agreements to be executed

April 11, 2024
Page 2

and implemented on a schedule necessary to meet the Trial Operation date specified in Exhibit 'B', and replaced with, "The Control Area within ERCOT is a single Control Area with ERCOT assuming authority as the Control Area operator in accordance with the ERCOT Protocols."

- The following references to the PUCT Substantive Rules in Article 1. Definitions, were changed, PUCT Rule 25.198(g) to 25.198(d); 25.5(23) to 25.5(56); 25.196(e) to 25.191(d) (3).
- Due to the nature of the co-tenant arrangement where multiple generating entities share the same Point of Interconnection, the Interconnection Agreement has been modified as follows:
 - the following definition was modified in Article 1. Definitions: "GIF";
 - the following definitions were added in Article 1. Definitions: "Co-Tenant Agreements", "Co-Tenant Generator(s)", "Co-Tenant Switchyard Facilities", "Co-Tenant Transmission Line", "Texas Waves, LLC", and "Texas Waves, LLC Agreement"; and
 - the following sections were modified: Article 2. Termination, Section 2.3, Disconnection; Article 10. Miscellaneous, Sections 10.4, Notices and Section 10.6, Default.

In addition to these changes, Oncor Electric Delivery has redacted certain financial information located in Exhibit D.

Sincerely,



Thomas J. Yamin, P.E.
Director

AMENDED AND RESTATED
ERCOT STANDARD GENERATION
INTERCONNECTION AGREEMENT

PYRON WIND REPOWER

GINR 23INR0525

TABLE OF CONTENTS

Exhibit "A"

Terms and Conditions of the ERCOT

Standard Generation Interconnection Agreement.....	6
ARTICLE 1. DEFINITIONS.....	6
ARTICLE 2. TERMINATION.....	8
ARTICLE 3. REGULATORY FILINGS.....	9
ARTICLE 4. INTERCONNECTION FACILITIES ENGINEERING, PROCUREMENT, AND CONSTRUCTION.....	10
ARTICLE 5. FACILITIES AND EQUIPMENT.....	13
ARTICLE 6. OPERATION AND MAINTENANCE.....	16
ARTICLE 7. DATA REQUIREMENTS.....	17
ARTICLE 8. PERFORMANCE OBLIGATION.....	18
ARTICLE 9. INSURANCE.....	19
ARTICLE 10. MISCELLANEOUS.....	21
Exhibit "B" Time Schedule.....	29
Exhibit "C" Interconnection Detail.....	30
Exhibit "D" Contact and EFT Information.....	44
Exhibit "E" Security Arrangements.....	44

ERCOT STANDARD GENERATION INTERCONNECTION AGREEMENT

This amendment and restatement of the ERCOT Standard Generation Interconnection Agreement, dated October 15, 2007, is made and entered into this ____ day of _____, 2024, between Oncor Electric Delivery Company LLC, a Delaware limited liability company (“Transmission Service Provider”) and Pyron Wind Farm, LLC (formerly known as Airtricity Pyron Wind Farm, LLC) (“Generator”), hereinafter individually referred to as “Party,” and collectively referred to as “Parties”. In consideration of the mutual covenants and agreements herein contained, the Parties hereto agree as follows:

Transmission Service Provider represents that it is a public utility that owns and operates facilities for the transmission and distribution of electricity. Generator represents that it will own and operate the Plant. Pursuant to the terms and conditions of this Agreement, Transmission Service Provider shall interconnect Generator’s Plant with Transmission Service Provider’s System consistent with the Facilities Study Agreement executed between the Parties on **March 6, 2007**.

This Agreement applies only to the Plant and the Parties’ interconnection facilities as identified in Exhibit “C”.

This Agreement shall become effective upon execution, subject to Governmental Authority approval, if required, and shall continue in full force and effect until terminated in accordance with Exhibit “A”.

This Agreement will be subject to the following, all of which are incorporated herein:

- A. The “Terms and Conditions of the ERCOT Standard Generation Interconnection Agreement” attached hereto as Exhibit “A”;
- B. The ERCOT Requirements (unless expressly stated herein, where the ERCOT Requirements are in conflict with this Agreement, the ERCOT Requirements shall prevail);
- C. The PUCT Rules (where the PUCT Rules are in conflict with this Agreement, the PUCT Rules shall prevail);
- D. The Time Schedule attached hereto as Exhibit “B”;
- E. The Interconnection Details attached hereto as Exhibit “C”;
- F. The notice requirements attached hereto as Exhibit “D”; and
- G. The Security Arrangement Details attached hereto as Exhibit “E”

IN WITNESS WHEREOF, the Parties have executed this Agreement in duplicate originals, each of which shall constitute and be an original effective Agreement between the Parties.

ONCOR ELECTRIC DELIVERY COMPANY
LLC

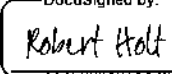
By: 
DocuSigned by:
1A4F398A21AA462...

Name: Robert Holt
Print or type

Title: Director, Transmission Services

Date: 3/14/2024

PYRON WIND FARM, LLC

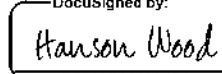
By: 
DocuSigned by:
17C84AB9819A4B0...

Name: Hanson wood
Print or type

Title: SVP Onshore Renewable Development

Date: 3/14/2024

Exhibit “A”
Terms and Conditions of the ERCOT
Standard Generation Interconnection Agreement

ARTICLE 1. DEFINITIONS

Capitalized terms shall have the meanings as set forth below, except as otherwise specified in the Agreement:

1.1 “CCN” shall mean a Certificate of Convenience and Necessity issued by the PUCT.

1.2 “Commercial Operation” shall mean the date on which Generator declares that the construction of the Plant has been substantially completed, Trial Operation of the Plant has been completed, and the Plant is ready for dispatch.

1.3 “Control Area” shall have the meaning ascribed thereto in PUCT Rule 25.5(19) or its successor.

1.4 “Co-Tenant Agreements” shall mean this Pyron Wind Farm LLC (Pyron Wind Repower – 23INR0525) ERCOT Standard Generation Interconnection Agreement and the Texas Waves, LLC Agreement (Pyron BESS I – 09INR0017 and 20INR0268 – Pyron BESS II aka Texas Waves I and II).

1.5 “Co-Tenant Generator(s)”: The “Co-Tenant Generators” shall mean Generator - 23INR0525 (Pyron Wind Farm, LLC) and Texas Waves, LLC (on behalf of both Pyron BESS I - 09INR0017 Phase III and Pyron BESS II - 20INR0268), collectively; the “Other Co-Tenant Generator” shall mean Texas Waves, LLC (Pyron BESS I and II).

1.6 “Co-Tenant Switchyard Facilities” shall be the GIF switchyard facilities owned jointly by the Co-Tenant Generators, as described in Exhibit “C”.

1.7 “Co-Tenant Transmission Line” shall be the GIF transmission line owned jointly by the Co-Tenant Generators, as described in Exhibit “C”.

1.8 “ERCOT” shall mean the Electric Reliability Council of Texas, Inc.

1.9 “ERCOT Requirements” means the ERCOT Operating Guides, ERCOT Generation Interconnection Procedures as well as any other documents adopted by ERCOT relating to the interconnection and operation of generators and transmission systems in ERCOT as amended from time to time, and any successors thereto. Any requirement in the foregoing documents imposed upon generation entities or generation facilities shall become the responsibility of the Generator,

and any requirements imposed on transmission providers or transmission facilities shall become the responsibility of the TSP.

1.10 “Facilities Study” shall have the meaning as described in PUCT Rule 25.198(d) or its successor.

1.11 “Facilities Study Agreement” shall mean an agreement executed by the Parties relating to the performance of the Facilities Study.

1.12 “GIF” shall mean Co-Tenant Switchyard Facilities, Co-Tenant Transmission Line, and Generator Switchyard, as described in Exhibit “C”.

1.13 “Good Utility Practice” shall have the meaning described in PUCT Rule 25.5(56) or its successor.

1.14 “Governmental Authority (ies)” shall mean any federal, state, local or municipal body having jurisdiction over a Party.

1.15 “In-Service Date” shall be the date, as reflected in Exhibit “B”, that the TIF will be ready to connect to the GIF.

1.16 “Plant” shall mean the electric generation facility owned and operated by the Generator, as specified in Exhibit “C”.

1.17 “Point of Interconnection” shall mean the location(s) where the GIF connects to the TIF as negotiated and defined by the Parties and as shown on Exhibit “C” of this Agreement.

1.18 “PUCT” shall mean the Public Utility Commission of Texas.

1.19 “PUCT Rules” shall mean the Substantive Rules of the PUCT.

1.20 “Reasonable Efforts” shall mean the use of Good Utility Practice and the exercise of due diligence (pursuant to PUCT Rule 25.191(d)(3)).

1.21 “Texas Waves, LLC” shall mean that party who is a party to the Texas Waves, LLC Agreement, and its permitted successors and assigns.

1.22 “Texas Waves, LLC Agreement” shall mean that certain ERCOT Standard Generation Interconnection Agreement between TSP and Texas Waves LLC, executed concurrently with the execution of this Agreement, as the same may be amended from time to time.

1.23 “System Protection Equipment” shall mean those facilities located within the TIF and the GIF as described in Section 5.6 and Exhibit “C”.

1.24 “System Security Study” shall have the meaning as described in PUCT Rule 25.198(c) or its successor.

1.25 “TCOS” shall mean the TSP’s transmission cost of service as allowed by the applicable Governmental Authority.

1.26 “TIF” shall mean the TSP’s interconnection facilities as described in Exhibit “C” to this Agreement.

1.27 “Trial Operation” shall mean the process by which the Generator is engaged in on-site test operations and commissioning of the Plant prior to Commercial Operation.

1.28 “TSP” shall mean the Transmission Service Provider.

1.29 “TSP System” shall mean the electric transmission facilities, including the TIF, and all associated equipment and facilities owned and/or operated by the TSP.

ARTICLE 2. TERMINATION

2.1 Termination Procedures. This Agreement may be terminated as follows:

A. the Generator may terminate this Agreement after giving the TSP thirty (30) days advance written notice; or

B. the TSP may terminate this Agreement (subject to Governmental Authority approval, if required) on written notice to the Generator if the Generator’s Plant has not achieved Commercial Operation within one year after the scheduled Commercial Operation date reflected in Exhibit “B”; or

C. either Party may terminate this Agreement in accordance with Section 10.6.

2.2 Termination Costs. If a Party elects to terminate the Agreement pursuant to Section 2.1 above, the Generator shall pay all costs incurred (or committed to be incurred) by TSP, as of the date of the other Party’s receipt of such notice of termination, that are the responsibility of the Generator under this Agreement. In the event of termination by either Party, both Parties shall use

commercially reasonable efforts to mitigate the damages and charges that they may incur as a consequence of termination. The provisions of the Sections 2.2 and 2.3 shall survive termination of the Agreement.

2.3 Disconnection.

A. Upon termination of this Agreement, Generator will open its connection to the Co-Tenant Switchyard Facilities and leave such connection open. If Generator fails, within five (5) calendar days after TSP's provision of written notice to the Co-Tenant Generators, to open its connection to the Co-Tenant Switchyard Facilities or maintain such open connection, TSP shall have the right to disconnect the TIF from the GIF.

B. As a result of the Co-Tenant Generators' co-ownership of portions of the GIF, it is expressly recognized and agreed to by Generator that if a Co-Tenant Agreement is terminated and the Co-Tenant Generator who is party to such agreement fails, within five (5) calendar days after TSP's provision of written notice to the Co-Tenant Generators, to open its connection to the Co-Tenant Switchyard Facilities or maintain such open connection, TSP shall have the right to disconnect the TIF from the GIF, regardless of the status of this Agreement, and shall have the right to maintain the disconnection of the TIF from the GIF until said Co-Tenant Generator opens its connection to the Co-Tenant Switchyard Facilities and maintains such open connection.

ARTICLE 3. REGULATORY FILINGS

3.1 Filing. The TSP shall file this executed Agreement with the appropriate Governmental Authority, if required. Any portions of this Agreement asserted by Generator to contain competitively sensitive commercial or financial information shall be filed by the TSP identified as "confidential" under seal stating, for the TSP's showing of good cause, that Generator asserts such information is confidential information and has requested such filing under seal. If requested by the TSP, Generator shall provide the TSP, in writing, with the Generator's basis for asserting that the information referred to in this Section 3.1 is competitively sensitive information, and the TSP may disclose such writing to the appropriate Governmental Authority.

3.2 Regulatory Approvals. Unless exempt, the TSP shall timely request ERCOT and all regulatory approvals necessary for it to carry out its responsibilities under this Agreement. Such approvals shall include any CCN required for the construction of the TIF.

**ARTICLE 4. INTERCONNECTION FACILITIES ENGINEERING,
PROCUREMENT, AND CONSTRUCTION**

4.1 Options. The Generator shall select one of the following options (subsection A or subsection B) and include the selected option in Exhibit “B” for completion of the TIF:

A. The TSP shall design, procure, and construct the TIF, using Reasonable Efforts to complete the TIF by the In-Service Date reflected in Exhibit “B”. The TSP will utilize its own resources and will contract for additional resources, as reasonably necessary, to meet the In-Service Date. Such resources shall include, as the TSP believes is reasonable, use of other contractors, other equipment suppliers, other material suppliers, additional contract personnel, additional payments to contractors for expedited work, and premiums paid to equipment and material suppliers for expedited delivery. The TSP shall not be required to undertake any initiative which is inconsistent with its standard safety practices, its material and equipment specifications, its design criteria and construction procedures, its labor agreements, applicable laws and regulations, and ERCOT Requirements. In the event the TSP reasonably expects that it will not be able to complete the TIF by the In-Service Date, the TSP will promptly provide written notice to the Generator and will undertake Reasonable Efforts to meet the earliest date thereafter.

B. (i) The TSP shall design, procure, and construct the TIF by the In-Service Date reflected in Exhibit “B”. The Parties acknowledge that the In-Service Date was either agreed upon through good faith negotiations or designated by the Generator upon failure of the Parties to agree. In the process of negotiating the In-Service Date, Generator will request a date upon which it reasonably expects it will be ready to begin use of the TIF and upon which it reasonably expects to begin doing so. Any date designated by the Generator shall in no event be less than fifteen months from the date that all conditions of Sections 4.2 and 4.3 have been satisfied. The designated In-Service Date will be extended day for day for each day that the ERCOT refuses to grant clearances to install equipment. If the TSP fails to complete the TIF by the In-Service Date reflected in Exhibit “B”, the TSP shall pay the Generator liquidated damages in accordance with this Section 4.1.B.

(ii) The Parties agree that actual damages to the Generator, in the event the TIF are not completed by the In-Service Date, may include Generator’s fixed operation and maintenance costs and lost opportunity costs. Such actual damages are uncertain and impossible to determine at this time. The Parties agree that, because of such uncertainty, any liquidated damages paid by the TSP

to the Generator shall be an amount equal to $\frac{1}{2}$ of 1% of the actual cost of the TIF, per day. However, in no event shall the total liquidated damages exceed 20% of the actual cost of the TIF. The Parties agree that such liquidated damages are less than the Generator's actual damages. The Parties agree that the foregoing payments will be made by the TSP to the Generator as just compensation for the damages caused to the Generator, which actual damages are uncertain and impossible to determine at this time, and as reasonable liquidated damages, but not as a penalty or a method to secure performance of this Agreement.

(iii) The TSP shall apply to have the full costs of the TIF included in TCOS. If the PUCT issues a final, appealable order excluding from TCOS any portion of the TIF costs, including higher contractor and vendor costs due to liquidated damage provisions in those contracts and insurance costs to cover liquidated damages, which costs may have been reasonably incurred but which the PUCT finds should not be recovered through TCOS, the Generator shall reimburse the TSP for such costs in an amount not to exceed the difference between the TSP's estimate of the cost of the TIF under section 4.1.A and the TSP's estimate of the cost of the TIF under Section 4.1.B as reflected in Exhibit "C". Such costs shall be estimated using Good Utility Practice.

(iv) No liquidated damages shall be paid to Generator if the Generator is not ready to commence use of the TIF for the delivery of power to the Plant for Trial Operation or export of power from the Plant on the In-Service Date, unless the Generator would have been able to commence use of the TIF for the delivery of power to the Plant for Trial Operation or export of power from the Plant but for TSP's delay.

(v) If the In-Service Date has been designated by the Generator upon a failure of the Parties to agree on the In-Service Date, the TSP may, at its option, require the Generator to subcontract with the TSP for all or part of the design, procurement and construction of the TIF in accordance with the TSP's standard subcontractor agreements. In such event, the TSP shall be subject to the payment of liquidated damages to the Generator only if the In-Service Date is not met solely due to the TSP's failure to complete the portion of the TIF for which the TSP has retained responsibility. It is the intent of this subsection to give the TSP full control of the contents and quality of the TIF. To the extent the Generator acts as a subcontractor to the TSP, the following will apply: 1) The Generator shall engineer, procure equipment, and construct the TIF (or portions thereof) using Good Utility Practice and using standards and specifications provided in advance

by the TSP; 2) In its engineering, procurement and construction of the TIF, the Generator shall comply with all requirements of law to which the TSP would be subject in the engineering, procurement or construction of the TIF; 3) The TSP shall review and approve the engineering design, acceptance tests of equipment, and the construction of the TIF; 4) The TSP shall have the right to approve and accept for operation the TIF in accordance with the standards and specifications provided in advance by the TSP, such approval and acceptance shall not be unreasonably withheld, conditioned, or delayed; 5) Should any phase of the engineering, equipment procurement, or construction of the TIF, including selection of subcontractors, not meet the standards and specifications provided by the TSP, and therefore be deemed unacceptable, then the Generator shall be obligated to remedy that portion of the TIF or selection of subcontractors that is deemed unacceptable, the TSP's approval of the Generator's selection of subcontractors will not be unreasonably withheld, conditioned or delayed; and 6) Once the TIF is accepted for operation by the TSP, then the TSP shall reimburse the Generator for the reasonable and necessary costs incurred by the Generator to complete the TIF, not to exceed the amount specified in the subcontract. Such reimbursement shall be made within thirty days after receipt of the invoice, unless otherwise agreed to by the Parties.

4.2 Equipment Procurement. If responsibility for construction of the TIF is borne by the TSP, then the TSP shall commence design of the TIF and procure necessary equipment within a reasonable time after all of the following conditions are satisfied:

- A. The TSP has completed the Facilities Study pursuant to the Facilities Study Agreement;
- B. The TSP has received written authorization to proceed with design and procurement from the Generator by the date specified in Exhibit "B"; and
- C. The Generator has provided security to the TSP in accordance with Section 8.3 by the dates specified in Exhibit "B".

4.3 Construction Commencement. The TSP shall commence construction of the TIF as soon as practicable after the following additional conditions are satisfied:

- A. Approval of the appropriate Governmental Authority has been obtained for any facilities requiring regulatory approval;
- B. Necessary real property rights, if any, have been obtained;

C. The TSP has received written authorization to proceed with construction from the Generator by the date specified in Exhibit “B”; and

D. The Generator has provided security to the TSP in accordance with Section 8.3 by the dates specified in Exhibit “B”.

4.4 Work Progress. The Parties will keep each other advised periodically as to the progress of their respective design, procurement and construction efforts. If, at any time, the Generator becomes aware that the completion of the TIF will not be required until after the specified In-Service Date, the Generator will promptly provide written notice to the TSP of a new, later In-Service Date.

4.5 Conditions Precedent Delay. To the extent this Agreement incorporates a specified In-Service Date and the Generator fails to satisfy conditions precedent under Sections 4.2 and 4.3 so that the TSP may meet the In-Service Date, the Parties will negotiate in good faith to establish a new schedule for completion of the TIF.

ARTICLE 5. FACILITIES AND EQUIPMENT

5.1 Information Exchange. The Parties shall exchange information and mutually agree upon the design and compatibility of the Parties’ interconnection facilities. The Parties shall work diligently and in good faith to make any necessary design changes to ensure compatibility of the GIF to the TSP System.

5.2 GIF Construction. Generator agrees to cause the GIF to be designed and constructed in accordance with Good Utility Practice, ERCOT Requirements and the National Electrical Safety Code in effect at the time of construction. Within one-hundred and twenty (120) days after Commercial Operation, unless the Parties agree on another mutually acceptable deadline, the Generator shall deliver to the TSP the following “as-built” drawings, information and documents for the GIF: a one-line diagram, a site plan showing the Plant and the GIF, plan and elevation drawings showing the layout of the GIF, a relay functional diagram, relaying AC and DC schematic wiring diagrams and relay settings for all facilities associated with the Generator’s main-power transformers, the facilities connecting the Generator to the main power transformers and the GIF, and the impedances (determined by factory tests) for the associated main power transformers and the generators.

5.3 TIF Construction. The TSP agrees to cause the TIF to be designed and constructed in accordance with Good Utility Practice, ERCOT Requirements and the National Electrical Safety Code in effect at the time of construction.

5.4 Equipment Changes. For facilities not described in Exhibit "C", if either Party makes equipment changes to the Plant, the GIF, the TIF or the TSP System which it knows will affect the operation or performance of the other Party's interconnection facilities, the Parties agree to notify the other Party, in writing, of such changes. Such changes shall be made in accordance with ERCOT Requirements and coordinated between the Parties.

5.5 Metering, Telemetry and Communications Requirements.

A. Metering and telemetry of data will be accomplished in accordance with ERCOT Requirements. The specific metering, telemetry and communications equipment to be installed and data to be telemetered are described in Exhibit "C".

B. At the Point of Interconnection, the metering and telemetry equipment shall be owned by the TSP. However, the TSP shall provide the Generator with metering and telemetry values in accordance with ERCOT Requirements.

C. A minimum set of inputs to the telemetry equipment are specified in Exhibit "C". Additional sets of inputs may be subsequently mutually agreed upon.

D. The TSP will notify the Generator at least five (5) working days in advance of any planned maintenance, inspection, testing, or calibration of the metering equipment, unless otherwise agreed to in writing. The Generator, or its designated representative, shall have the right to be present for these activities and to receive copies of any documents related to the procedures and results.

E. Prior to the connection of the GIF to the TIF, acceptance tests will be performed by the owning Party to ensure the proper functioning of all metering, telemetry and communications equipment associated with the Point of Interconnection and both Parties' interconnection facilities, and to verify the accuracy of data being received by the TSP, the Control Area(s) in which the Plant and the TSP are located and the Generator. All acceptance tests will be performed consistent with ERCOT Requirements.

F. The TSP shall, in accordance with Good Utility Practice and ERCOT Requirements, specify communications facilities, including those necessary to transmit data from the metering equipment to the TSP, that are necessary for the effective operation of the Plant and

the GIF with the TSP System. Such communication facilities shall be included in Exhibit "C". The Generator shall make arrangements to procure and bear the cost of such facilities.

G. Any changes to the meters, telemetry equipment, voltage transformers, current transformers, and associated panels, hardware, conduit and cable, which will affect the data being received by the other Party must be mutually agreed to by the Parties.

H. Each Party will promptly advise the other Party if it detects or otherwise learns of any metering, telemetry or communications equipment errors or malfunctions that require the attention and/or correction by the other Party. The Party owning such equipment shall correct such error or malfunction as soon as reasonably feasible in accordance with ERCOT Requirements.

5.6 System Protection and Other Controls Requirements.

A. Each Party's facilities shall be designed to isolate any fault, or to correct or isolate any abnormality, that would negatively affect the other Party's system or other entities connected to the TSP System.

B. The Generator shall be responsible for protection of its facilities consistent with ERCOT Requirements.

C. Each Party's protective relay design shall incorporate the necessary test switches to perform the tests required in Section 5.6.F. The required test switches will be placed such that they allow operation of lockout relays while preventing breaker failure schemes from operating and causing unnecessary breaker operations and tripping the Generator's units.

D. Recording equipment shall be installed to analyze all system disturbances in accordance with ERCOT Requirements.

E. Each Party will test, operate and maintain System Protection Equipment in accordance with ERCOT Requirements. Each Party will provide reasonable notice to the other Party of any testing of its System Protection Equipment allowing such other Party the opportunity to have representatives present during testing of its System Protection Equipment.

F. Prior to the In-Service Date, and again prior to Commercial Operation, each Party or its agent shall perform a complete calibration test and functional trip test of the System Protection Equipment. At intervals suggested by Good Utility Practice or at intervals described in the ERCOT Requirements if so defined therein, and following any apparent malfunction of the System Protection Equipment, each Party shall perform both calibration and functional trip tests of its System Protection Equipment. These tests do not require the tripping of any in-service

generation unit. These tests do, however, require that all protective relays and lockout contacts be activated.

5.7 No Annexation. Any and all equipment placed on the premises of a Party shall be and remain the property of the Party providing such equipment regardless of the mode and manner of annexation or attachment to real property, unless otherwise mutually agreed by the Parties.

ARTICLE 6. OPERATION AND MAINTENANCE

6.1 Operation and Maintenance of Interconnection Facilities. The Parties agree to operate and maintain their systems in accordance with Good Utility Practice, National Electrical Safety Code, the ERCOT Requirements, PUCT Rules and all applicable laws and regulations. Subject to any necessary ERCOT approval, each Party shall provide necessary equipment outages to allow the other Party to perform periodic maintenance, repair or replacement of its facilities. Such outages shall be scheduled at mutually agreeable times, unless conditions exist which a Party believes, in accordance with Good Utility Practice, may endanger persons or property. No changes will be made in the normal operation of the Point of Interconnection without the mutual agreement of the Parties except as otherwise provided herein. All testing of the Plant that affects the operation of the Point of Interconnection shall be coordinated between the TSP, the Control Area(s) in which the Plant and the TSP are located, and the Generator and will be conducted in accordance with ERCOT Requirements.

6.2 Control Area Notification. The Control Area within ERCOT is a single Control Area with ERCOT assuming authority as the Control Area operator in accordance with the ERCOT Protocols.

6.3 Land Rights and Easements. Terms and conditions addressing the rights of the TSP and the Generator regarding any facilities located on the other Party's property shall be addressed in a separate, duly executed and recorded easement agreement between the Parties. Prior to Commercial Operation, the Parties will mutually agree upon procedures to govern access to each other's property as necessary for the Parties to fulfill their obligations hereunder.

6.4 Service Interruption. The Parties recognize that the interruption of service provisions of the PUCT Rules give TSP the right to disconnect the TSP System from the Plant under the conditions specified therein. The Generator will promptly disconnect the Plant from the TSP System when required by and in accordance with the PUCT Rules and ERCOT Requirements.

6.5 Switching and Clearance.

A. Any switching or clearances needed on the TIF or the GIF will be done in accordance with ERCOT Requirements.

B. Any switching and clearance procedure necessary to comply with Good Utility Practice or ERCOT Requirements that may have specific application to the Plant shall be addressed in Exhibit "C".

6.6 Start-Up and Synchronization. Consistent with ERCOT Requirements and the Parties' mutually acceptable procedure, the Generator is responsible for the proper synchronization of the Plant to the TSP System.

6.7 Routine Operational Communications. On a timely basis, the Parties shall exchange all information necessary to comply with ERCOT Requirements.

6.8 Blackstart Operations. If the Plant is capable of blackstart operations, Generator will coordinate individual Plant start-up procedures consistent with ERCOT Requirements. Any blackstart operations shall be conducted in accordance with the blackstart criteria included in the ERCOT Requirements and the TSP Blackstart Plan on file with the ERCOT. Notwithstanding this section, the Generator is not required to have blackstart capability by virtue of this Agreement. If the Generator will have blackstart capability, then Generator shall provide and maintain an emergency communication system that will interface with the TSP during a blackstart condition.

6.9 Power System Stabilizers. The Generator shall procure, install, maintain and operate power system stabilizers if required to meet ERCOT Requirements and as described in Exhibit "C".

ARTICLE 7. DATA REQUIREMENTS

7.1 Data Acquisition. The acquisition of data to realistically simulate the electrical behavior of system components is a fundamental requirement for the development of a reliable interconnected transmission system. Therefore, the TSP and the Generator shall be required to submit specific information regarding the electrical characteristics of their respective facilities to each other as described below in accordance with ERCOT Requirements.

7.2 Initial Data Submission by TSP. The initial data submission by the TSP shall occur no later than 120 days prior to Trial Operation and shall include transmission system data necessary to allow the Generator to select equipment and meet any system protection and stability requirements.

7.3 Initial Data Submission by Generator. The initial data submission by the Generator, including manufacturer data, shall occur no later than 90 days prior to the Trial Operation and shall include a completed copy of the following forms contained in the ERCOT's Generation Interconnection Procedure: (1) Plant Description/Data and (2) Generation Stability Data. It shall also include any additional data provided to the ERCOT for the System Security Study. Data in the initial submissions shall be the most current Plant design or expected performance data. Data submitted for stability models shall be compatible with the ERCOT standard models. If there is no compatible model, the Generator will work with an ERCOT designated consultant to develop and supply a standard model and associated data.

7.4 Data Supplementation. Prior to Commercial Operation, the Parties shall supplement their initial data submissions with any and all "as-built" Plant data or "as-tested" performance data which differs from the initial submissions or, alternatively, written confirmation that no such differences exist. Subsequent to Commercial Operation, the Generator shall provide the TSP any data changes due to equipment replacement, repair, or adjustment. The TSP shall provide the Generator any data changes due to equipment replacement, repair, or adjustment in the directly connected substation or any adjacent TSP-owned substation that may affect the GIF equipment ratings, protection or operating requirements. The Parties shall provide such data no later than 30 days after the date of the actual change in equipment characteristics. Also, the Parties shall provide to each other a copy of any additional data later required by the ERCOT concerning these facilities.

7.5 Data Exchange. Each Party shall furnish to the other Party real-time and forecasted data as required by ERCOT Requirements. The Parties will cooperate with one another in the analysis of disturbances to either the Plant or the TSP's System by gathering and providing access to any information relating to any disturbance, including information from oscillography, protective relay targets, breaker operations and sequence of events records.

ARTICLE 8. PERFORMANCE OBLIGATION

8.1 Generator's Cost Responsibility. The Generator will acquire, construct, operate, test, maintain and own the Plant and the GIF at its sole expense. In addition, the Generator may be required to make a contribution in aid of construction in the amount set out in and for the facilities described in Exhibit "C", if any, in accordance with PUCT Rules.

8.2 TSP's Cost Responsibility. The TSP will acquire, own, operate, test, and maintain the TIF at its sole expense, subject to the provisions of Section 4.1.B and the contribution in aid of construction provisions of Section 8.1 of this Agreement.

8.3 Financial Security Arrangements. The TSP may require the Generator to pay a reasonable deposit or provide another means of security, to cover the costs of planning, licensing, procuring equipment and materials, and constructing the TIF. The required security arrangements shall be specified in Exhibit "E". Within five business days after the Plant achieves Commercial Operation, the TSP shall return the deposit or security to the Generator. However, the TSP may retain an amount to cover the incremental difference between the TSP's actual out of pocket costs associated with the choice of Section 4.1.B over Section 4.1.A, pending a final PUCT Order as contemplated in Section 4.1.B(iii). If the Plant has not achieved Commercial Operation within one year after the scheduled Commercial Operation date identified in Exhibit "B" or if the Generator terminates this Agreement in accordance with Section 2.1 and the TIF are not required, the TSP may, subject to the provisions of Section 2.2, retain as much of the deposit or security as is required to cover the costs it incurred in planning, licensing, procuring equipment and materials, and constructing the TIF. If a cash deposit is made pursuant to Exhibit "E", any repayment of such cash deposit shall include interest at a rate applicable to customer deposits as established from time to time by the PUCT or other Governmental Authority.

ARTICLE 9. INSURANCE

9.1 Each Party shall, at its own expense, maintain in force throughout the period of this Agreement and until released by the other Party the following minimum insurance coverages, with insurers authorized to do business in Texas:

A. Employers Liability and Worker's Compensation Insurance providing statutory benefits in accordance with the laws and regulations of the State of Texas. The minimum limits for the Employer's Liability insurance shall be One Million Dollars (\$1,000,000) each accident bodily injury by accident, One Million Dollars (\$1,000,000) each employee bodily injury by disease, and One Million Dollars (\$1,000,000) policy limit bodily injury by disease.

B. Commercial General Liability Insurance including premises and operations, personal injury, broad form property damage, broad form blanket contractual liability coverage (including coverage for the contractual indemnification) products and completed operations coverage, coverage for explosion, collapse and underground hazards, independent contractors

coverage, coverage for pollution to the extent normally available and punitive damages to the extent normally available and a cross liability endorsement, with minimum limits of One Million Dollars (\$1,000,000) per occurrence/One Million Dollars (\$1,000,000) aggregate combined single limit for personal injury, bodily injury, including death and property damage.

C. Comprehensive Automobile Liability Insurance for coverage of owned, non-owned and hired vehicles, trailers or semi-trailers designed for travel on public roads, with a minimum combined single limit of One Million Dollars (\$1,000,000) per occurrence for bodily injury, including death, and property damage.

D. Excess Public Liability Insurance over and above the Employer's Liability, Commercial General Liability and Comprehensive Automobile Liability Insurance coverage, with a minimum combined single limit of Twenty Million Dollars (\$20,000,000) per occurrence/Twenty Million Dollars (\$20,000,000) aggregate.

E. The Commercial General Liability Insurance, Comprehensive Automobile Liability Insurance, and Excess Public Liability Insurance policies shall name the other Party, its parent, associated and affiliated companies and their respective directors, officers, agents, servants and employees ("Other Party Group") as additional insured. All policies shall contain provisions whereby the insurers waive all rights of subrogation in accordance with the provisions of this Agreement against the Other Party Group and provide thirty (30) days advance written notice to Other Party Group prior to anniversary date of cancellation or any material change in coverage or condition.

F. The Commercial General Liability Insurance, Comprehensive Automobile Liability Insurance and Excess Public Liability Insurance policies shall contain provisions that specify that the policies are primary and shall apply to such extent without consideration for other policies separately carried and shall state that each insured is provided coverage as though a separate policy had been issued to each, except the insurer's liability shall not be increased beyond the amount for which the insurer would have been liable had only one insured been covered. Each Party shall be responsible for its respective deductibles or retentions.

G. The Commercial General Liability Insurance, Comprehensive Automobile Liability Insurance and Excess Public Liability Insurance policies, if written on a Claims First Made basis, shall be maintained in full force and effect for two (2) years after termination of this

Agreement, which coverage may be in the form of tail coverage or extended reporting period coverage if agreed by the Parties.

H. The requirements contained herein as to the types and limits of all insurance to be maintained by the Parties are not intended to and shall not in any manner, limit or qualify the liabilities and obligations assumed by the Parties under this Agreement.

I. Within ten (10) days following execution of this Agreement, and as soon as practicable after the end of each fiscal year or at the renewal of the insurance policy and in any event within ninety (90) days thereafter, each Party shall provide certification of all insurance required in this Agreement, executed by each insurer or by an authorized representative of each insurer.

J. Notwithstanding the foregoing, each Party may self-insure to the extent it maintains a self-insurance program; provided that, such Party's senior long term debt is rated at investment grade, or better, by Standard & Poor's or Moody's Investor's Service. For any period of time that a Party's senior long term debt is unrated by Standard & Poor's and Moody's Investor's Service or is rated at less than investment grade by Standard & Poor's and Moody's Investor's Service, such Party shall comply with the insurance requirements applicable to it under Sections 9.1.A through 9.1.I. In the event that a Party is permitted to self-insure pursuant to this Section 9.1.J, it shall not be required to comply with the insurance requirements applicable to it under Sections 9.1.A through 9.1.I.

K. The Parties agree to report to each other in writing as soon as practical all accidents or occurrences resulting in injuries to any person, including death, and any property damage arising out of this Agreement.

ARTICLE 10. MISCELLANEOUS

10.1 Governing Law and Applicable Tariffs.

A. This Agreement for all purposes shall be construed in accordance with and governed by the laws of the State of Texas, excluding conflicts of law principles that would refer to the laws of another jurisdiction. The Parties submit to the jurisdiction of the federal and state courts in the State of Texas.

B. This Agreement is subject to all valid, applicable rules, regulations and orders of, and tariffs approved by, duly constituted Governmental Authorities.

C. Each Party expressly reserves the right to seek changes in, appeal, or otherwise contest any laws, orders, rules, or regulations of a Governmental Authority.

10.2 No Other Services. This Agreement is applicable only to the interconnection of the Plant to the TSP System at the Point of Interconnection and does not obligate either Party to provide, or entitle either Party to receive, any service not expressly provided for herein. Each Party is responsible for making the arrangements necessary for it to receive any other service that it may desire from the other Party or any third party. This Agreement does not address the sale or purchase of any electric energy, transmission service or ancillary services by either Party, either before or after Commercial Operation.

10.3 Entire Agreement. This Agreement, including all Exhibits, Attachments and Schedules attached hereto, constitutes the entire agreement between the Parties with reference to the subject matter hereof, and supersedes all prior and contemporaneous understandings or agreements, oral or written, between the Parties with respect to the subject matter of this Agreement. There are no other agreements, representations, warranties, or covenants which constitute any part of the consideration for, or any condition to, either Party's compliance with its obligations under this Agreement. Notwithstanding the other provisions of this Section, the Facilities Study Agreement, if any, is unaffected by this Agreement.

10.4 Notices. Except as otherwise provided in Exhibit "D", any formal notice, demand or request provided for in this Agreement shall be in writing and shall be deemed properly served, given or made if delivered in person, or sent by either registered or certified mail, postage prepaid, overnight mail or fax to the address or number identified on Exhibit "D" attached to this Agreement. Either Party may change the notice information on Exhibit "D" by giving five business days written notice prior to the effective date of the change. As a result of the Co-Tenant Generators' joint ownership of portions of the GIF, it is expressly agreed that Generator may not change the notice information in Section (a) of Exhibit "D", without TSP's express prior written consent to the change; provided, however, that Generator may change the notice information in Section (a) of Exhibit "D" without TSP's prior written consent by giving five business days written notice prior to the effective date of the change and the Other Co-Tenant Generators make the same change in notice information under their respective Co-Tenant Agreements as of the effective date of such notice. It is further agreed that, unless otherwise provided at the time of execution of this Agreement, prior to TSP completing the TIF and

placing such facilities into service, Generator will revise Exhibit “D” in accordance with the provisions of this paragraph and provide the revised Exhibit “D” to TSP to reflect all missing telephone numbers, fax numbers, and other required information. Notice to the Other Co-Tenant Generators does not constitute notice to Generator.

10.5 Force Majeure.

A. The term “Force Majeure” as used herein shall mean any cause beyond the reasonable control of the Party claiming Force Majeure, and without the fault or negligence of such Party, which materially prevents or impairs the performance of such Party’s obligations hereunder, including but not limited to, storm, flood, lightning, earthquake, fire, explosion, failure or imminent threat of failure of facilities, civil disturbance, strike or other labor disturbance, sabotage, war, national emergency, or restraint by any Governmental Authority.

B. Neither Party shall be considered to be in Default (as hereinafter defined) with respect to any obligation hereunder (including obligations under Article 4), other than the obligation to pay money when due, if prevented from fulfilling such obligation by Force Majeure. A Party unable to fulfill any obligation hereunder (other than an obligation to pay money when due) by reason of Force Majeure shall give notice and the full particulars of such Force Majeure to the other Party in writing or by telephone as soon as reasonably possible after the occurrence of the cause relied upon. Telephone notices given pursuant to this Section shall be confirmed in writing as soon as reasonably possible and shall specifically state full particulars of the Force Majeure, the time and date when the Force Majeure occurred and when the Force Majeure is reasonably expected to cease. The Party affected shall exercise due diligence to remove such disability with reasonable dispatch, but shall not be required to accede or agree to any provision not satisfactory to it in order to settle and terminate a strike or other labor disturbance.

10.6 Default

A. The term “Default” shall mean the failure of either Party to perform any obligation in the time or manner provided in this Agreement. No Default shall exist where such failure to discharge an obligation (other than the payment of money) is the result of Force Majeure as defined in this Agreement or the result of an act or omission of the other Party. Upon a Default, the non- defaulting Party shall give written notice of such Default to the defaulting Party. Provided further, that in the event of a Default by Generator, TSP shall give written notice of such Default to Generator

and the Other Co-Tenant Generators. Except as provided in Section 10.6.B, the defaulting Party shall have thirty (30) days from receipt of the Default notice within which to cure such Default; provided however, if such Default is not capable of cure within 30 days, the defaulting Party shall commence such cure within 30 days after notice and continuously and diligently complete such cure within 90 days from receipt of the Default notice; and, if cured within such time, the Default specified in such notice shall cease to exist; and further provided that either or both of the Other Co-Tenant Generators shall have the right to cure the Default.

- B. If a Default is not cured as provided in this Section, or if a Default is not capable of being cured within the period provided for herein, the non-defaulting Party shall have the right to terminate this Agreement by written notice at any time until cure occurs, and be relieved of any further obligation hereunder and, whether or not that Party terminates this Agreement, to recover from the defaulting Party all amounts due hereunder, plus all other damages and remedies to which it is entitled at law or in equity. The provisions of this Section will survive termination of this Agreement.
- C. If a non-TSP Default occurs that is not cured as provided in this Section or is not cured under a Co-Tenant Agreement, in accordance with the Default and cure provisions set forth in such agreement, and TSP is unable to finally determine whether Generator or an Other Co-Tenant Generator is responsible for the Default, TSP may terminate both this Agreement and the Co-Tenant Agreements. As used in this subsection 10.6(C), the term Default shall also mean the failure of an Other Co-Tenant Generator to perform any obligation in the time or manner provided in the applicable Co-Tenant Agreement.

10.7 Intrastate Operation. The operation of the Plant by Generator shall not cause there to be a synchronous or an asynchronous interconnection between ERCOT and any other transmission facilities operated outside of ERCOT unless ordered by the Federal Energy Regulatory Commission under Section 210 of the Federal Power Act. The Parties recognize and agree that any such interconnection will constitute an adverse condition giving the TSP the right to immediately disconnect the TIF from the GIF, until such interconnection has been disconnected. The Generator will not be prohibited by this Section from interconnecting the Plant with facilities operated by the Comisión Federal de Electricidad of Mexico, unless such interconnection would

cause ERCOT utilities that are not “public utilities” under the Federal Power Act to become subject to the plenary jurisdiction of the Federal Energy Regulatory Commission.

10.8 No Third Party Beneficiaries. This Agreement is not intended to and does not create rights, remedies, or benefits of any character whatsoever in favor of any persons, corporations, associations, or entities other than the Parties, and the obligations herein assumed are solely for the use and benefit of the Parties, their successors in interest and, where permitted, their assigns.

10.9 No Waiver. The failure of a Party to this Agreement to insist, on any occasion, upon strict performance of any provision of this Agreement will not be considered a waiver of obligations, rights, or duties imposed upon the Parties. Termination or Default of this Agreement for any reason by the Generator shall not constitute a waiver of the Generator’s legal rights to obtain an interconnection from the TSP under a new interconnection agreement.

10.10 Headings. The descriptive headings of the various articles and sections of this Agreement have been inserted for convenience of reference only and are of no significance in the interpretation or construction of this Agreement.

10.11 Multiple Counterparts. This Agreement may be executed in two or more counterparts, each of which is deemed an original but all constitute one and the same instrument.

10.12 Amendment. This Agreement may be amended only upon mutual agreement of the Parties, which amendment will not be effective until reduced to writing and executed by the Parties.

10.13 No Partnership. This Agreement shall not be interpreted or construed to create an association, joint venture, agency relationship, or partnership between the Parties or to impose any partnership obligation or liability upon either Party. Neither Party shall have any right, power or authority to enter into any agreement or undertaking for, or act on behalf of, or to act as or be an agent or representative of, or to otherwise bind, the other Party.

10.14 Further Assurances. The Parties agree to (i) furnish upon request to each other such further information, (ii) execute and deliver to each other such other documents, and (iii) do such other acts and things, all as the other Party may reasonably request for the purpose of carrying out the intent of this Agreement and the documents referred to in this Agreement. Without limiting the generality of the foregoing, the TSP shall, at the Generator’s expense, when reasonably requested to do so by the Generator at any time after the execution of this Agreement, prepare and provide such information in connection with this Agreement (including, if available, resolutions, certificates, opinions of counsel or other documents relating to the TSP’s corporate authorization

to enter into this Agreement and to undertake the obligations set out herein) as may be reasonably required by any potential lender to the Generator under a proposed loan agreement. The TSP will use commercially reasonable efforts to obtain any opinion of counsel reasonably requested by Generator, but the TSP shall not be in Default of any obligation under this Agreement if the TSP is unable to provide an opinion of counsel that will satisfy any potential lender to the Generator. Specifically, upon the written request of one Party, the other Party shall provide the requesting Party with a letter stating whether or not, up to the date of the letter, that Party is satisfied with the performance of the requesting Party under this Agreement.

10.15 Indemnification and Liability. The indemnification and liability provisions of the PUCT Rule 25.202(b)(2) or its successor shall govern this Agreement.

10.16 Consequential Damages. OTHER THAN THE LIQUIDATED DAMAGES HERETOFORE DESCRIBED, IN NO EVENT SHALL EITHER PARTY BE LIABLE UNDER ANY PROVISION OF THIS AGREEMENT FOR ANY LOSSES, DAMAGES, COSTS OR EXPENSES FOR ANY SPECIAL, INDIRECT, INCIDENTAL, CONSEQUENTIAL, OR PUNITIVE DAMAGES, INCLUDING BUT NOT LIMITED TO LOSS OF PROFIT OR REVENUE, LOSS OF THE USE OF EQUIPMENT, COST OF CAPITAL, COST OF TEMPORARY EQUIPMENT OR SERVICES, WHETHER BASED IN WHOLE OR IN PART IN CONTRACT, IN TORT, INCLUDING NEGLIGENCE, STRICT LIABILITY, OR ANY OTHER THEORY OF LIABILITY; PROVIDED, HOWEVER, THAT DAMAGES FOR WHICH A PARTY MAY BE LIABLE TO THE OTHER PARTY UNDER ANOTHER AGREEMENT WILL NOT BE CONSIDERED TO BE SPECIAL, INDIRECT, INCIDENTAL, OR CONSEQUENTIAL DAMAGES HEREUNDER.

10.17 Assignment. This Agreement may be assigned by either Party only with the written consent of the other; provided that either Party may assign this Agreement without the consent of the other Party to any affiliate of the assigning Party with an equal or greater credit rating and with the legal authority and operational ability to satisfy the obligations of the assigning Party under this Agreement; and provided further that the Generator shall have the right to assign this Agreement, without the consent of the TSP, for collateral security purposes to aid in providing financing for the Plant, provided that the Generator will require any secured party, trustee or mortgagee to notify the TSP of any such assignment. Any financing arrangement entered into by the Generator pursuant to this Section will provide that prior to or upon the exercise of the secured party's,

trustee's or mortgagee's assignment rights pursuant to said arrangement, the secured creditor, the trustee or mortgagee will notify the TSP of the date and particulars of any such exercise of assignment right(s). Any attempted assignment that violates this Section is void and ineffective. Any assignment under this Agreement shall not relieve a Party of its obligations, nor shall a Party's obligations be enlarged, in whole or in part, by reason thereof. Where required, consent to assignment will not be unreasonably withheld, conditioned or delayed.

10.18 Severability. If any provision in this Agreement is finally determined to be invalid, void or unenforceable by any court having jurisdiction, such determination shall not invalidate, void or make unenforceable any other provision, agreement or covenant of this Agreement; provided that if the Generator (or any third-party, but only if such third-party is not acting at the direction of the TSP) seeks and obtains such a final determination with respect to any provision of Section 4.1.B, then none of the provisions of Section 4.1.B. shall thereafter have any force or effect and the Parties' rights and obligations shall be governed solely by Section 4.1.A.

10.19 Comparability. The Parties will comply with all applicable comparability and code of conduct laws, rules and regulations, as amended from time to time.

10.20 Invoicing and Payment. Unless the Parties otherwise agree (in a manner permitted by applicable PUCT Rules and as specified in writing in an Exhibit "E" attached hereto), invoicing and payment rights and obligations under this Agreement shall be governed by PUCT Rules or applicable Governmental Authority. Invoices shall be rendered to the paying Party at the address specified on, and payments shall be made in accordance with the requirements of, Exhibit "D".

10.21 Confidentiality.

A. Subject to the exception in Section 10.21.B, any information that a Party claims is competitively sensitive, commercial or financial information under this Agreement ("Confidential Information") shall not be disclosed by the other Party to any person not employed or retained by the other Party, except to the extent disclosure is (i) required by law; (ii) reasonably deemed by the disclosing Party to be required to be disclosed in connection with a dispute between or among the Parties, or the defense of litigation or dispute; (iii) otherwise permitted by consent of the other Party, such consent not to be unreasonably withheld; or (iv) necessary to fulfill its obligations under this Agreement or as a transmission service provider or a Control Area operator including disclosing the Confidential Information to the ERCOT. The Party asserting confidentiality shall notify the other Party in writing of the information it claims is confidential. Prior to any disclosures

of the other Party's Confidential Information under this subsection, or if any third party or Governmental Authority makes any request or demand for any of the information described in this subsection, the disclosing Party agrees to promptly notify the other Party in writing and agrees to assert confidentiality and cooperate with the other Party in seeking to protect the Confidential Information from public disclosure by confidentiality agreement, protective order or other reasonable measures.

B. This provision shall not apply to any information that was or is hereafter in the public domain (except as a result of a breach of this provision).

10.22 Representations and Restrictions on Certain Foreign Ownership and Affiliation. Generator represents and warrants that it does not meet any of the ownership, control, or headquarters criteria listed in Lone Star Infrastructure Protection Act, Chapter 117 of the Texas Business & Commerce Code (relating to China, Iran, North Korea, Russia, and any other country designated by the Texas governor as a threat to critical infrastructure).

Exhibit "B" **Time Schedule**

Interconnection Option chosen by Generator (check one): X Section 4.1.A. or Section 4.1.B

If Section 4.1.B is chosen by Generator, the In-Service Date(s) was determined by (check one):
(1) good faith negotiations, or (2) Designated by Generator upon failure to agree.

In - Service Date(s): **September 15, 2023**

Scheduled Trial Operation Date: **October 4, 2023**

Scheduled Commercial Operation Date: **April 5, 2024**

Due to the nature of the subject of this Agreement, the Parties may mutually agree to change the dates and times of this Exhibit "B".

Due to the nature of the subject of this Agreement, the Parties may mutually agree to change the dates and times of this Exhibit "B".

Exhibit “C” Interconnection Details

1. Name: **PYRON WIND REPOWER**
2. Point of Interconnection location: The point of interconnection is located in Scurry County, Texas, in TSP’s Morgan Creek – Graham 345 kV line. Specifically, the point of interconnection shall be defined as the points where TSP’s 345 kV conductors connect to Co-Tenant Generator’s 4-hole pad connections at the end of Co-Tenant Generator’s 345 kV bus, located at the fence separating TSP’s Tonkawa 345 kV Switching Station from the Co-Tenant Generator’s switchyard. (See attached one-line diagram.)
3. Delivery Voltage: **345 kV**
4. Number and size of Generating Units:

GIR No. 23INR0525

166 wind turbine generators, each rated at 1.62 MW for a total of **268.92 MW**

5. Type of Generating Unit:

GIR No. 23INR0525

GE SLE Wind Turbine Generator

The Parties will amend this Exhibit “C” as necessary to reflect any changes Generator makes to the manufacturer, model, or type of generating units.

6. Metering and Telemetry Equipment: Metering (voltage, location, losses adjustment due to metering location, and other), telemetry, and communications requirements shall be as follows:
 - a. TSP shall, in accordance with ERCOT Requirements and Good Utility Practice, install, own, operate, inspect, test, calibrate, and maintain **345 kV** metering accuracy potential and current transformers and associated metering and telemetry equipment (including an RTU) located in the TIF. A one-line diagram showing TSP’s ERCOT-pollled settlement (“EPS”) metering location is attached to this Exhibit “C” as Attachment 1. TSP will connect its EPS primary meter(s) to its RTU via a communication link. Primary EPS metering data may be made available to Generator via a Generator-owned communication link connected to TSP’s RTU, using TSP’s available RTU protocol. Such data, if provided to Generator, will be for Generator’s informational purposes only. Generator shall not rely on such data, as the primary source, for the metering data addressed in item 6b. below, or for any other scheduling or operational purposes. TSP makes no guarantee of the quality or availability of such data. The provisions of Exhibit “A”, Section 5.5G., shall not apply to TSP’s RTU.
 - b. Generator shall, in accordance with Good Utility Practice, install, own, operate, inspect, test, calibrate, and maintain the necessary metering potential and current

transformers and associated metering and telemetry equipment in the GIF and/or Plant to satisfy the ERCOT Requirements for the provision of metering data by Generator's "Qualified Scheduling Entity".

- c. Generator shall, in accordance with ERCOT Requirements and Good Utility Practice, install, own, operate, inspect, test, calibrate, and maintain the metering and telemetry equipment (including an RTU or other equipment acceptable to TSP) to supply all electrical parameters of the Plant and GIF, as specified in the SCADA Table in Attachment 2 to this Exhibit "C", to TSP at a location designated by TSP.
- d. Generator shall, in accordance with ERCOT Requirements and Good Utility Practice, provide communications facilities that are, or may in the future be, necessary for effective interconnected operation of the Generator's Plant with the transmission system. Generator will directly make arrangements to procure and will bear the procurement, installation and ongoing costs of items (i) and (ii) below. The communications facilities will include (see Attachment 2A to Exhibit "C"):
 - (i) one private line voice circuit (an off-premise extension of TSP's PBX) in the Control Center referenced in Section 12(b) below, as shown on Exhibit D. The telephone handset for this voice line will be located in the Control Center such that personnel responsible for controlling voltage of the Plant will have continuous, ready access to the handset to receive calls from TSP's control center.
 - (ii) one communication path, acceptable to TSP, that will deliver the Generator switchyard data specified in Attachment 2 to Exhibit "C" from Generator's RTU (using an RS-232 output) to TSP's control center. Generator shall use DNP 3.0 protocol (or other protocol acceptable to TSP). The communication path shall avoid the use of the public internet. TSP will provide rack space at a location designated by TSP for Generator's communication interface equipment.
- e. Prior to the In-Service Date, acceptance tests will be performed by TSP and Generator to ensure the proper functioning of all metering, telemetry, and communications equipment, and to verify the accuracy of data being received by TSP.
- f. Following the Commercial Operation date, each Party shall test its metering, telemetry, and communications equipment in accordance with ERCOT Requirements and Good Utility Practice. Each Party shall give the other Party reasonable advance notice of such testing. Each Party shall have the right to observe testing performed by the other Party.
- g. Any changes to Generator's metering, telemetry, and communication equipment, including meters, voltage transformers, current transformers, and associated RTU, panels, hardware, conduit and cable, that will affect the data being received by TSP hereunder must be mutually agreed to by the Parties.

- h. Each Party will promptly advise the other Party if it detects or otherwise learns of any metering, telemetry, or communications equipment or related situation that requires attention and/or correction by the other Party.
 - i. Generation Meter Splitting – The data measured by the EPS Meter will be allocated to the Co-Tenant Generators in accordance with Section 10.3.2.1 of the ERCOT Protocols, or its successor. Such arrangement must be approved by ERCOT in accordance with such ERCOT Protocols.
7. Generator Interconnection Facilities: The GIF shall include the following facilities. (See the attached one-line diagram)

Co-Tenant Generator Switchyard Facilities

- (1 lot) Circuit breakers, 345 kV with two sets of 3000/5, C800 CT's with a TRF = 2.0 for bus current differential relaying
- (1 lot) Switches, air break, 345 kV, gang operated, 3 phase, with provisions for TSP pad lock
- (1 lot) PT or CCVT, 345 kV, dual secondary windings as required for Generator metering and relaying
- (1 lot) Protective relaying equipment necessary to interface with TSP relaying equipment for protection of the 345 kV tap bus, and related breaker failure protection schemes
- (1 ea.) Expansion of existing supervisory equipment, SCADA RTU
- (1 ea.) Expansion of existing Fault Recording equipment (as required by ERCOT)
- (1 lot) Metering, Telemetry, and Communications Equipment
- (1 lot) Associated structures, bus-work, conductor, connectors, grounding, conduit, control cable, foundation work, perimeter fencing, grading/dirt work and any appurtenances necessary for construction and operation of the GIF

The above list is not intended to be a complete list of all facilities that are part of the GIF.

8. Transmission Service Provider Interconnection Facilities: The TIF shall include the following facilities. (See the attached one-line diagram)

TSP Tonkawa 345 kV Switching Station

The Tonkawa 345 kV Switching Station is being provided pursuant to the Standard Generation Interconnection Agreement for Roscoe Wind Farm Phase I. The system improvements at the Tonkawa 345 kV Switching Station for Airtricity Pyron Wind Phase III require expanding the station to a four breaker ring bus. Additional interconnect facilities for this interconnection are described as follows:

a. Switchyard Equipment

The following list of major switchyard equipment will be necessary for interconnection of Airtricity Texas Waves Phase III at the Tonkawa 345 kV Switching Station.

- (1 ea.) Circuit breaker, 345 kV, 3200 amperes, 50 kA
- (2 ea.) Switch, air break, 345 kV, 3200 amperes, gang operated, 3 phase
- (3 ea.) Metering Current Transformers, 345 kV
- (3 ea.) CCVT's, 345 kV, dual secondary windings for metering and relaying
- (3 ea.) Surge arresters, 345 kV
- (1 lot) All galvanized steel structures, including switch stands, metering structures, surge arrester supports, CCVT supports, and bus supports necessary for construction and operation of the TSP switchyard facilities
- (1 ea.) Expansion of existing supervisory equipment, SCADA RTU
- (1 ea.) Expansion of existing Digital Fault Recorder
- (1 lot) Associated bus-work, conductor, connectors, grounding, conduit, control cable, foundation work, perimeter fencing, grading/dirt work, and any appurtenances necessary for construction and operation of the TSP switchyard facilities

b. Relaying Equipment

The following relay panels will be necessary for the Tonkawa 345 kV Switching Station.

- (1 ea.) Generator line relay panel, with controls for one breaker
- (1 ea.) Bus Differential panel
- (1 ea.) Metering panel with totalizing equipment

The above lists are not intended to be complete lists of all facilities that are part of the TIF.

9. Communications Facilities: See Item 6 above.
10. System Protection Equipment: See Section 5.6 of Exhibit "A" and Attachment 3 to this Exhibit "C".
11. Inputs to Telemetry Equipment: See Attachment 2 to this Exhibit "C".
12. Supplemental Terms and Conditions:
 - a. For additional supplemental terms and conditions, see Attachments 1, 2, and 3 to this Exhibit "C".
 - b. Generator Control Center - Generator will establish a control center that shall be staffed 24 hours per day, 7 days per week, by personnel capable of making operating decisions and possessing the ability and authority to directly control voltage at the Plant, including the control of all devices at the Plant (such as

generators, reactors and capacitors) associated with controlling such voltage (“Generator Control Center”). In the event that the Generator Control Center is not located at the Plant, the voltage control described in the preceding sentence will be accomplished directly by Generator Control Center personnel via a supervisory control and data acquisition (SCADA) system directly asserting control over all voltage control equipment at the Plant. Prior to TSP completing the TIF and placing such facilities in service, the Parties will revise Exhibit D to incorporate any missing telephone numbers for the Generator in Section (a).

- c. If Generator Owns Land - If Generator will own the land in fee upon which TSP will construct the TIF, or portion thereof, Generator will provide to TSP, at no cost to TSP, a deed and/or easement(s) in perpetuity, in form and substance satisfactory to TSP, for such land or land rights as are needed for the TIF and TSP’s use of the All Weather Road on any land owned in fee by Generator. Generator will provide such deed and/or easement(s) to TSP by the date(s) specified in Exhibit “B”. The easement for the Tonkawa Switch property shall be an exclusive perpetual easement.
- d. If Generator Does Not Own Land – The following provisions will apply if Generator will not own the land in fee upon which TSP will construct the TIF.
 - a. TSP’s completion of the TIF by the date specified in Exhibit “B” is contingent upon the land owner(s) granting to TSP either a deed or easement(s) in perpetuity, in form and substance satisfactory to TSP, for such land or land rights needed for the TIF by the date specified in Exhibit “B”. The easement for the Tonkawa Switch property shall be an exclusive perpetual easement.
 - b. If the Generator has obtained certain land rights from the fee owner of the land upon which the TIF will be constructed, Generator will (i) enter into good faith negotiations with the fee owner of such land to assist TSP in obtaining, at no cost to TSP, either a deed or easement(s) in perpetuity, in form and substance satisfactory to TSP, for such land or land rights needed for the TIF, by the date(s) specified in Exhibit “B” and (ii) cooperate with TSP and the fee owner of such land in the development of legal documentation, satisfactory to TSP, which specifies that the land rights to be granted to TSP by the fee owner of such land will control in the event of conflict between such land rights and the aforementioned land rights held by Generator.
- e. Names and Device Numbers – Generator and TSP will collaborate and reach mutual agreement on the establishment of: i) unique name(s) for the Generator’s substations, unit main transformers, and switching station(s) connected at transmission voltage), ii) device numbers for all transmission voltage level switches and breakers which will be owned by Generator, and iii) unique names for Generator’s generating units, in accordance with ERCOT Requirements. Generator will submit to TSP, its proposed name(s) as referenced in this paragraph, to the TSP by the date specified in Exhibit “B”. Generator will register the name(s) of the facilities specified in this paragraph and Generator-owned device numbers at

ERCOT, in accordance with ERCOT Requirements, and such names and device numbers will be consistent with the names and numbers mutually agreed upon pursuant to this paragraph. Generator will not change any of the names or device numbers, established pursuant to this paragraph, without written approval of TSP. Generator will label the devices, referenced in item (ii) above, with the numbers assigned to such devices.

- f. Encroachments – If Generator desires to conduct any of the following activities within any portion of TSP’s right of way associated with TSP’s transmission or distribution lines: i) construct transmission lines, distribution lines, communication facilities, roads, water lines, sewer lines, gas pipelines, or any other facilities, ii) store any equipment or materials, or iii) change the grade, elevation, or contour of the land, Generator must submit its request to TSP using a form of request acceptable to TSP and obtain written authorization from TSP for such encroachment prior to Generator installing such facilities or conducting such activities. **TSP RESERVES THE RIGHT TO DELAY THE ENERGIZATION OF THE POINT OF INTERCONNECTION UNTIL GENERATOR OBTAINS ALL REQUIRED WRITTEN AUTHORIZATIONS FROM TSP FOR SUCH ENCROACHMENTS, IF ANY.** The Generator will be responsible for the cost of all modifications needed on facilities owned by TSP which are the result of such encroachment. The provision of overall site plans by Generator shall not relieve Generator from the obligation to submit all encroachment requests in accordance with this subsection (f).
- g. Site Plan - Generator will provide to TSP, by the date specified in Exhibit “B”, a site plan in sufficient detail to reflect the proposed routes and locations of Generator’s generating units, transmission lines, distribution lines, substations, transformers, and roads.
- h. Location of turbines – Generator will provide to TSP, by the date specified in Exhibit “B”, the Latitude and Longitude of each turbine to enable the identification of the PUCT certificated service area in which each turbine is located.
- i. Power Supply to Switching Station - Generator will, at Generator’s expense, by the date specified in Exhibit “B”, be responsible for (i) making arrangements, acceptable to TSP, with a certificated utility for the installation of a 120/240 volt AC distribution voltage point of interconnection for TSP’s use at TSP’s Tonkawa Switch and (ii) providing such point of interconnection at a location designated by TSP. TSP will make arrangements for and bear the cost of power and energy taken from such point of interconnection.
- j. Additional Studies – If it is necessary for TSP to perform any additional generation interconnection studies associated with the Plant in accordance with ERCOT Requirements (“Additional Studies”), the Parties will enter an agreement to perform the Additional Studies and Generator shall pay TSP for the Additional Studies pursuant to that agreement. The completion of such Study may reveal that additional TSP facilities will be required to be installed in conjunction with the

interconnection of the Plant. If TSP determines, as a result of the Additional Studies, that this Agreement needs to be amended to include additional facilities, the Parties will amend this Agreement to include (i) such additional facilities identified in the Additional Studies, and (ii) additional security requirements. Generator will provide an additional level of security in accordance with this Agreement to reflect any such additional facilities.

- k. Federal Income Tax – To the extent that a payment made by Generator to TSP pursuant to Sections 2.2 and 8.3 of Exhibit A is taxable income for federal income tax purposes, as determined by TSP, such payment shall be increased by an adder, as determined by TSP in accordance with its normal practices, to cover the effects of Generator’s payment on TSP’s tax liability.
- l. Reactive Power (Plant not generating real power) – Generator will install, operate, and maintain Plant and/or GIF facilities and implement an automatic operating scheme, as necessary, to establish and maintain reactive power within a range of +/- 5 Mvar, as measured at the Point of Interconnection, at all times when the Plant is not generating real power into the ERCOT grid and the Plant and/or GIF is acting as a load. Such facilities and automatic operating scheme will be installed and functional by the In-Service Date specified in Exhibit “B”. Generator will provide, for review and comments, written documentation to TSP specifying the design details of all equipment (including size, number, and location of any capacitors and/or reactors and controls) and automatic operating scheme which it will install to meet these requirements by the date specified in Exhibit “B”. Notwithstanding TSP’s obligations in the remainder of this Agreement, TSP shall have no obligation to establish an electrical interconnection with the GIF until Generator completes the installation of the reactive power facilities and automatic operating scheme specified in this paragraph.
- m. Reactive Power (Plant generating real power) – Generator will install, operate, and maintain Plant and GIF reactive power facilities, as necessary, to comply with the unit reactive power capability requirements at all times when the Plant is generating real power into the ERCOT grid, in accordance with ERCOT Requirements. Such facilities will be installed and functional prior to the Trial Operation of the Plant. Generator will provide, for review and comments, written documentation to TSP specifying the design details of all equipment (including size, number, and location of any capacitors and/or reactors and controls) which it will install to meet these requirements by the date specified in Exhibit “B”. Notwithstanding TSP’s obligations in the remainder of this Agreement, TSP shall have no obligation to establish an electrical interconnection with the GIF until Generator completes the installation of the reactive power facilities specified in this paragraph.
- n. Switching Procedures – To address the safety of field operations personnel of both Parties, the Parties will conduct the switching of transmission voltage devices owned by the TSP at the Point of Interconnection and all transmission voltage devices owned by Generator in accordance with TSP’s procedures. TSP will provide a copy of such procedures to Generator upon request.

- o. Facility Connection Requirements – Generator will construct its facilities in accordance with the version of Oncor Standard 520-108 that is in effect at the time the Generator gives its notice to proceed with design and procurement, as referenced in Exhibit “B”.
- p. Tap Position – In accordance with ERCOT Requirements, Generator will work with TSP to select the (no load) tap position on Generator’s main power transformer(s). Generator will initiate contact with TSP to select such tap position no later than the date specified in Exhibit “B”. Notwithstanding TSP’s obligations in the remainder of this Agreement, TSP shall have no obligation to establish an electrical interconnection with the GIF until Generator and TSP have selected the tap position.
- q. Relocation of Facilities - Unless otherwise agreed to in writing by TSP, Generator will (i) remove or relocate any existing Generator or third party underground and aboveground facilities from the property where the Tonkawa Switch will be constructed to a location acceptable to TSP and (ii) cause any existing Generator or third party easements on such property to be terminated by the date specified in Exhibit “B”.
- r. Grading and Drainage – Since Tonkawa Switch will be located adjacent to the Generator Switchyard on property being developed for the Generator facility, and in order to ensure that the Tonkawa Switch grading and drainage design is consistent with Generator’s overall grading and drainage design, Generator will be responsible for, in coordination with TSP, the design of the grading and drainage of TSP’s Tonkawa Switch site and associated All-Weather Road and entrance drives in accordance with TSP design specifications and requirements. Upon TSP approval of the grading designs, Generator will, at its cost, be responsible for grading of the TSP Tonkawa Switch site and associated All-Weather Road and entrance drives to Tonkawa Switch. Station site grading will be to top of Station subgrade elevations as identified in TSP’s notes and details “the subgrade elevations” as shown on the grading design drawings prepared by Generator and approved by TSP. TSP will install the final 6” of compacted flex base and 2” of topping rock surfacing to the station site at the end of construction. Generator will be responsible for complete installation of the All-Weather Road and entrance drives including the base material (no topping rock) in accordance with TSP design specifications. TSP shall have the option to test and inspect the material and installation. Generator will also be responsible for any required drainage improvements necessary to protect the Tonsite and All-Weather Road and entrance drives against possible erosion.

Grading and Drainage design associated with the TSP Tonkawa Switch site and associated All-Weather Road and entrance drives shall be performed in accordance with TSP specification number 500-051 - Site Preparation, and other site-specific design criteria, which will be provided by the TSP to the Generator. TSP shall

review and approve the grading and drainage design for Tonkawa Switch with the associated All-Weather Road and entrance drives prior to construction. TSP reserves the right to provide an on-site inspector during site preparation construction to confirm site construction follows TSP requirements. The grading and drainage design for the Tonkawa Switch site and associated All-Weather Road and access drives shall be submitted to TSP for review and approval and shall be completed by the dates specified in Exhibit "B".

In addition, Generator will be responsible for continuing maintenance of site drainage beyond the Tonkawa Switch site and associated All-Weather Road and entrance drives property/easement as it affects the station site and associated All-Weather Road and entrance drives integrity.

14. The difference between the estimated cost of the TIF under 4.1.A (\$____) and the estimated cost of the TIF under 4.1.B (\$_____) is: _____, if applicable.

Attachment 1 to Exhibit "C"

ONE LINE DIAGRAM
TONKAWA SWITCH

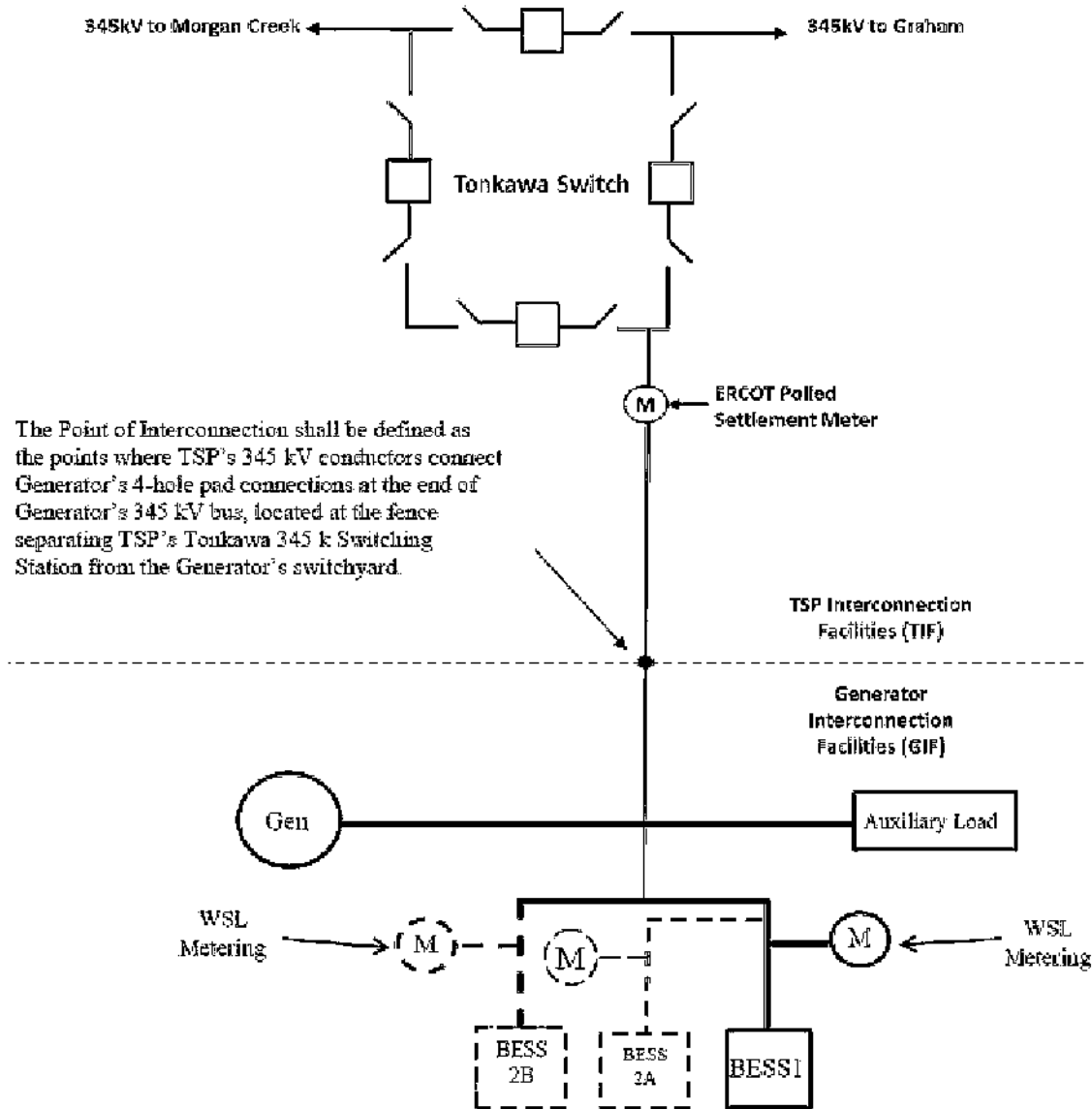

NOTE: This one-line diagram is for illustration only and shall not be used for purposes of design construction or operations.

Attachment 2 to Exhibit "C"

**SCADA TABLE
INFORMATION REQUIRED BY TSP FROM GENERATOR**

<u>GIF DEVICE/BUS</u>	<u>DATA REQUIRED</u>
Each 345 kV Breaker	Status indication, three phase megawatts, and three phase megavars (Dry type breaker "A" contacts required for indication and 0 - 1 milliamp analog signal required for megawatt and megavar information)
Each 345 kV Bus	A, B and C Phase voltages (0 – 1 milliamp analog signal required for voltage information)
Each Reactive Device Breaker	Status indication, three phase megawatts, and three phase megavars (Dry type breaker "A" contacts required for indication and 0 - 1 milliamp analog signal required for megawatt and megavar information)
Each 345 kV Switch, Each Reactive Device Switch	Status indication (Dry type "A" contacts required for indication)

Note: The SCADA Table above does not include real-time operational metering data or other data required by ERCOT from the Generator or its Qualified Scheduling Entity.

Attachment 2A to Exhibit "C" COMMUNICATION GUIDELINE

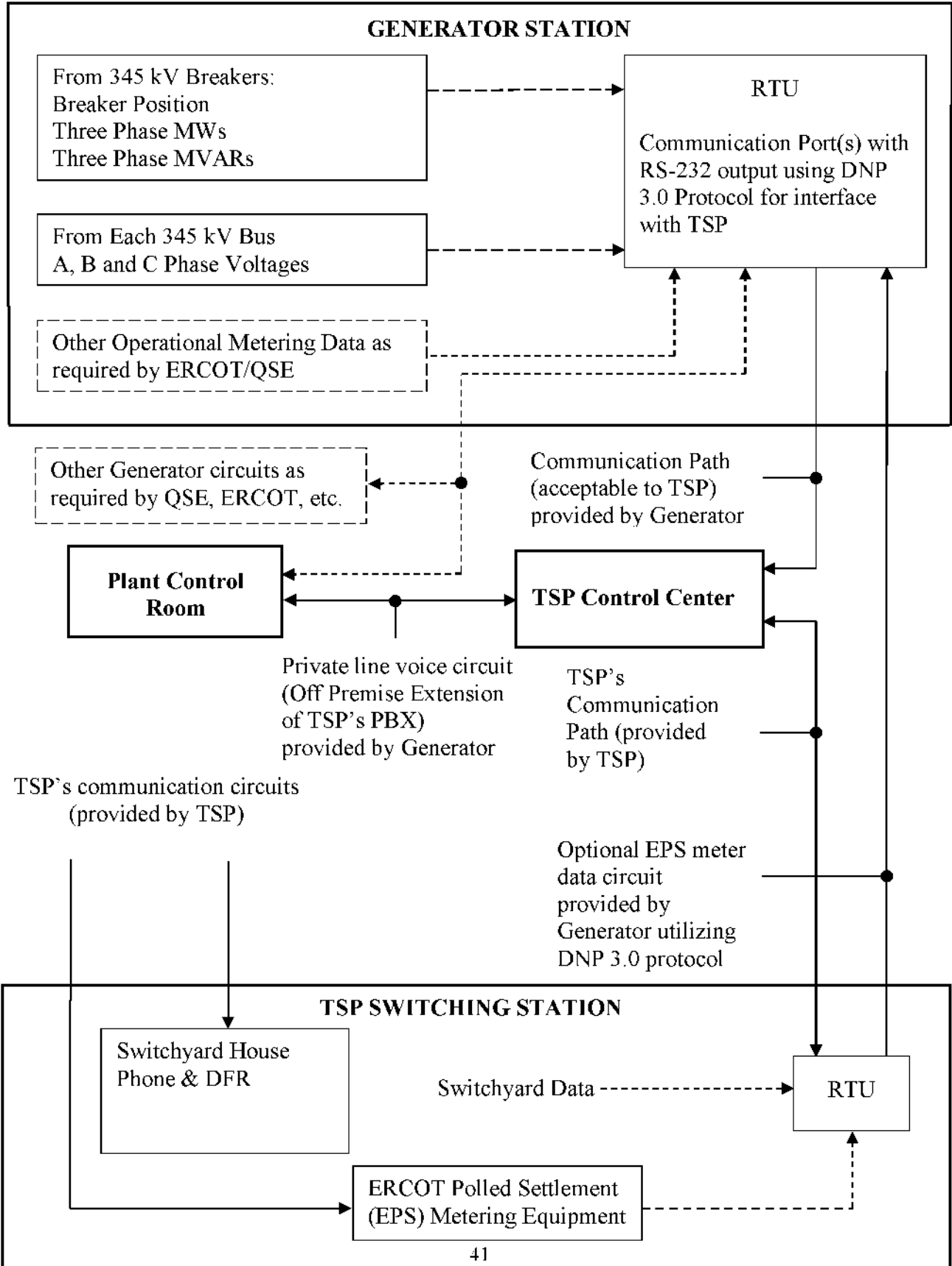

Attachment 3 to Exhibit “C”
SYSTEM PROTECTION REQUIREMENTS

In addition to the provisions of Sections 5.6 and 6.1 of this Agreement, the following provisions shall apply with respect to system protection issues. To the extent there is a conflict between Sections 5.6 or 6.1 of this Agreement and this Attachment 3 to Exhibit “C”, the provisions of this Attachment 3 to Exhibit “C” shall apply.

Generator and TSP shall design, install, operate, maintain, and test system protection equipment consistent with the applicable criteria as described in the ERCOT Requirements and any applicable requirements of Governmental Authorities, including NERC Reliability Standards. To the extent necessary to comply with the testing provisions of these requirements, including the time intervals of such requirements, the circuit breakers in the TIF will be tripped during the required testing, and thus may require an outage or reduction of generation at the Plant. Generator shall, at its expense, provide modifications or additions to its control and protective equipment required to comply with changes in ERCOT Requirements or requirements of Governmental Authorities, including complying with NERC Reliability Standards.

Generator, using Good Utility Practice, shall install sufficient digital fault recording equipment to thoroughly analyze all system disturbances occurring on the GIF and the Plant and to thoroughly analyze the Plant and GIF performance during system disturbances on the ERCOT system. This equipment shall monitor the voltages at major nodes, current at major branches, breaker and switch positions, and dc logic in the relay control scheme.

Generator will provide to the TSP its proposed system protection design, device settings, and other information, as referenced below (“Generator System Protection Components”) for review by TSP, by the date specified on Exhibit “B”. Generator shall not modify its Generator System Protection Components, at any time during the term of this Agreement, without first submitting such planned modifications to TSP for review. Such review by TSP will be for the limited purpose of determining if Generator’s System Protection Equipment is compatible with TSP’s System Protection Equipment. The Generator System Protection Components submitted by Generator shall include, but shall not necessarily be limited to:

1) Design components: scheme types, one line diagram, relay functional, type of protective relays and associated communication equipment, and trip circuit diagrams for the interconnection breakers.

2) Device settings and other information: device settings, CT and VT/CCVT information, transformer connection configuration, transformer tap position(s) and associated positive and zero sequence impedances, transmission line positive and zero sequence impedances, and generator impedances, including the saturated sub-transient impedance, when appropriate.

TSP shall specify system protection and control schemes for the Point of Interconnection. Generator shall have the right to review and comment on such schemes and TSP shall consider Generator's comments when determining such schemes. Generator will install and maintain System Protection Equipment that is compatible with TSP's System Protection Equipment. TSP will work with the Generator to coordinate the establishment of the relay settings for System Protection Equipment owned by both Generator and TSP associated with the Point of Interconnection.

If the GIF facilitates the interconnection of generators to the Southwest Power Pool (or any other reliability council other than ERCOT), Generator will utilize open circuit breakers and air-break switches (which provide visible open indication) as a means of isolating such generators from ERCOT prior to switching them to such other reliability council.

Generator will design, construct, and operate its electrical facilities such that all unit auxiliary power sources will come from the same reliability council to which the unit output is connected.

Exhibit "D"

Notice and Electronic Funds Transfer Information of the ERCOT Standard Generation Interconnection Agreement

(a) Dispatch Center Communications:

If to Transmission Service Provider:

Fax number at TSP control center:
(214) 273-6884

24/7 Telephone at TSP control center:
(214) 743-6897

If to Generator [see the provisions of Exhibit B, Exhibit C, section 12(b) and Exhibit C, section 6(d)(i)]:

Fax number at Generator Control Center: ()
- -

Off Premise Exchange Number for Generator Control Center: 512-482-8008

Other Generator Control Center 24/7 Number: ()
- -

(b) Notices of an administrative nature:

If to Transmission Service Provider:

Oncor Electric Delivery Company LLC
Attn: Robert Holt
777 Main Street, Suite 707
Fort Worth, Texas 76102
Phone: 817-215-5812
E-mail: Robert.Holt@oncor.com

If to Generator:

PYRON WIND FARM, LLC
Attn: Transmission Manager
1401 E 6th St, Suite 400
Austin, TX 78702
Phone: 512-658-9951
E-mail: transmission@rwc.com
CC: uslegal@rwc.com
Jennifer.aycrs-brasher@rwc.com

(c) Notice for statement and billing purposes:

If to: Transmission Service Provider

Oncor Electric Delivery Company LLC
Attn: Robert Holt
777 Main Street, Suite 707
Fort Worth, Texas 76102
Phone: 817-215-5812
E-mail: Robert.Holt@oncor.com

If to Generator:

PYRON WIND FARM, LLC
Attn: Accounts Payable
353 N Clark St, 30th Floor
Chicago, IL 60654
Phone: _____
E-mail: apinvoice.americas@rwc.com
CC: transmission@rwc.com
Jennifer.aycrs-brasher@rwc.com

(d) Information concerning Electronic Funds Transfers:

If to: Transmission Service Provider

JPMorgan Chase Bank

Houston, Texas
ABA No. [REDACTED]
For credit to:
Oncor Electric Delivery Company LLC
Account No. [REDACTED]

If to Generator:

[ENTER NAME OF BANK]
[ENTER ADDRESS]
[ENTER CITY, STATE, ZIP]
ABA No. _____
For credit to:

Account No. _____

Exhibit "E"
Security Arrangement Details

The TSP acknowledges that no material modifications to the TIF are needed to accommodate: i) the Generator's Plant upgrades pursuant to 23INR0525, or ii) the Generator's interconnection to the Load Facilities as detailed in this Agreement. As a result, a security instrument is not required for the TIF. In addition, Generator acknowledges that TSP, as of the date of this Agreement, has returned or otherwise released any security instrument previously held by TSP pursuant to the Original Agreement or any predecessors thereto.