

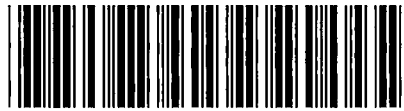

Control Number: 35077



Item Number: 1152

Addendum StartPage: 0



**SIXTH AMENDED AND RESTATED
INTERCONNECTION AGREEMENT
AMONG
AEP TEXAS INC.,
TAYLOR ELECTRIC COOPERATIVE, INC.
AND
GOLDEN SPREAD ELECTRIC COOPERATIVE, INC.**

DATED: 9/21/2020 | 9:50 AM EDT

**SIXTH AMENDED AND RESTATED
INTERCONNECTION AGREEMENT
AMONG
AEP TEXAS INC.,
TAYLOR ELECTRIC COOPERATIVE, INC.
AND
GOLDEN SPREAD ELECTRIC COOPERATIVE, INC.**

THIS SIXTH AMENDED AND RESTATED INTERCONNECTION AGREEMENT (“Agreement”), entered into as of 9/21/2020 | 9:50 AM EDT (“Execution Date”), by and among **AEP Texas Inc.**, a Texas corporation (“Company” or “AEP”), **Taylor Electric Cooperative, Inc.**, a Texas cooperative corporation (“Taylor” or “TEC”), and **Golden Spread Electric Cooperative, Inc.**, a Texas cooperative corporation (“Golden Spread” or “GSEC”). References to the “Parties” in the Agreement shall mean Company, Taylor and Golden Spread, collectively. References to a “Party” in the Agreement shall mean each individual Company, Taylor and Golden Spread. References to “Cooperative” in the Agreement shall mean Taylor or Golden Spread, as appropriate, depending on the Cooperative designated in Exhibit A and applicable Facility Schedule attached to the Agreement as the Cooperative that installs, owns, operates and maintains the Point of Interconnection facilities.

WITNESSETH

WHEREAS, the Parties each own and operate electric systems in the State of Texas for the transmission and distribution of electric energy and power; and

WHEREAS, the Parties are members of the Electric Reliability Council of Texas (“ERCOT”) and are subject to regulation by the Public Utility Commission of Texas (“PUCT”); and

WHEREAS, the Parties have established or shortly will establish new Points of Interconnection between their electrical systems; and

WHEREAS, the Parties entered into a Fifth Amended and Restated Interconnection Agreement dated March 12, 2020 (the “Fifth Amended and Restated Agreement”) in accordance with the AEP Open Access Transmission Service Tariff (“AEP OATT”) which required the Cooperative taking service under the AEP OATT to implement an interconnection agreement with the Company; and

WHEREAS, the Parties desire to amend and restate the Fifth Amended and Restated Agreement to amending Facility Schedule No. 22 that provides for Atwell Point of Interconnection. AEP is redesigning the Avenger interconnecting facilities that Atwell will be connecting to, from a box bay to a three switch structure; and

WHEREAS, the Parties desire to amend and restate the Fifth Amended and Restated Agreement by deleting Facility Schedule No. 23 that provides for Taylor’s Jim Ned Point of Interconnection. The Tuscola to Bradshaw section of the Abilene South to Steamboat 69 kV transmission line, which the Jim Ned Point of Interconnection is connecting to, belongs to another Transmission Service Provider, not AEP, thus the deletion is a correction to the Agreement; and

WHEREAS, the Parties desire to interconnect their respective transmission and/or distribution systems in the respects, and under the terms and conditions set forth below.

NOW, THEREFORE, in consideration of the premises and of the mutual covenants and conditions herein set forth, the Parties agree as follows:

ARTICLE I - EFFECTIVE DATE AND TERM

1.1 This Agreement and any subsequent addendum to this Agreement shall become effective on the date accepted by the Federal Energy Regulatory Commission (“FERC”), or any other regulatory agency or agencies having jurisdiction. The Parties shall request the FERC or any other regulatory agency or agencies having jurisdiction to make the effective date be the date first appearing above. This Agreement shall remain in effect for a period of two (2) years from the effective date, and shall continue in effect thereafter for periods of two (2) years each unless canceled after such initial period or any subsequent period either by mutual agreement or by either Party upon at least twenty-four (24) months written notice to the other Party. Upon termination of this Agreement, each Party shall discontinue the use of the facilities of the other and shall disconnect the Points of Interconnection.

1.2 Notwithstanding the foregoing Section 1.1, if Company serves such notice of termination and Cooperative reasonably determines that the continued interconnection of its facilities to the facilities of the Company is needed to provide continuous and adequate service to its customers, then both Parties shall enter into good faith negotiations concerning the terms of a replacement interconnection agreement. If the Parties cannot agree to the terms of such a replacement agreement that would become effective on or prior to the termination date of this Agreement, Company shall file an unexecuted replacement agreement with the FERC and Cooperative shall be entitled to challenge any provisions of such replacement agreement that are considered unjust or unreasonable, or unduly discriminatory. If Company assigns this Agreement pursuant to Article XII to an entity that is not subject to FERC jurisdiction a condition of such assignment shall be that the non-FERC jurisdictional entity shall file this Agreement or a proposed replacement agreement with the applicable state regulatory authority.

ARTICLE II – OBJECTIVE AND SCOPE

2.1 It is the intent of the Parties, by this Agreement, to state the terms and conditions under which the Parties’ transmission and/or distribution systems will be interconnected and to identify the facilities and equipment provided by each Party at the Points of Interconnection.

2.2 This Agreement shall apply to the ownership, construction, operation, and maintenance of those facilities that are specifically identified and described in the Facility Schedules that are attached hereto and incorporated herein.

2.3 This Agreement, including all attached Facility Schedules, constitutes the entire agreement and understanding between the Parties with regard to the interconnection of the facilities of the Parties at the Points of Interconnection expressly provided for in this Agreement. The Parties are not bound by or liable for any statement, representation, promise, inducement, understanding, or undertaking of any kind or nature (whether written or oral) with regard to the subject matter hereof if not set forth or provided for herein. This Agreement replaces and supersedes all other agreements and undertakings, oral and written, between the Parties with regard to the subject matter hereof. It is expressly acknowledged that the Parties may have other agreements covering other services not expressly provided for herein; such agreements are unaffected by this Agreement.

ARTICLE III - DEFINITIONS

For purposes of this Agreement, the following definitions shall apply:

3.1 Agreement means this Sixth Amended and Restated Interconnection Agreement, as amended and restated herein, together with all exhibits, schedules and attachments applying hereto, including any exhibits, schedules, attachments, and any amendments hereafter made.

3.2 ERCOT means the Electric Reliability Council of Texas, Inc., or its successor in function.

3.3 ERCOT Requirements shall mean the ERCOT Nodal Operating Guides and ERCOT Nodal Protocols, adopted by ERCOT, and approved by the PUCT, including any attachments or exhibits referenced in the ERCOT Nodal Protocols, as amended from time to time, that contain the scheduling, operating, planning, reliability, and settlement (including customer registration) policies, rules, guidelines, procedures, standards, and criteria of ERCOT.

3.4 Facility Schedule(s) shall mean the addendum(s) to this Agreement that describe the agreement on ownership, control, operation, and maintenance responsibilities of the Parties at the Point(s) of Interconnection.

3.5 Good Utility Practice shall mean any of the practices, methods and acts engaged in or approved by a significant portion of the electric utility industry during the relevant time period, or any of the practices, methods and acts which, in the exercise of reasonable judgment in light of the facts known at the time the decision was made, could have been expected to accomplish the desired result at a reasonable cost consistent with good business practices, reliability, safety, and expedition. Good Utility Practice is not intended to be limited to the optimum practice, method, or act to the exclusion of all others, but rather to be acceptable practices, methods, or acts generally accepted in the region. Good Utility Practice may include, but is not limited to, conformance with the applicable and consistently applied reliability criteria, standards and operating guides of ERCOT and the NERC, or successor organization(s).

3.6 NERC shall mean the North American Electric Reliability Corporation or its successor in function.

3.7 NERC Reliability Standards shall mean the mandatory electric reliability standards approved by the FERC and enforced by NERC.

3.8 Point(s) of Interconnection shall mean the points of interconnection identified in Exhibit A and the Facilities Schedules which are attached hereto and incorporated herein and future points of interconnection that may be established under this Agreement at which the electrical systems of the Parties are connected or may, by the closure of normally open switches, be connected.

3.9 PUCT shall mean the Public Utility Commission of Texas or its successor in function.

ARTICLE IV - ESTABLISHMENT AND TERMINATION OF POINTS OF INTERCONNECTION

4.1 The Parties agree to comply with NERC Reliability Standards as they relate to the interconnection of their facilities at the locations identified and described in the Facility Schedules which are attached hereto and incorporated herein.

4.2 The Parties agree to interconnect their facilities at the locations, and in accordance with the terms and conditions, specified in the attached Facility Schedule(s). All Points of Interconnection shall be specified in Exhibit A and the Facility Schedule(s) attached hereto and made a part hereof. The Facility Schedule(s) shall specify the responsibilities of the Parties with respect to ownership, control, operation, and maintenance of the interconnection facilities.

4.3 [Reserved]

4.4 Unless otherwise provided in a Facility Schedule, each Party shall, at each Point of Interconnection, at its own risk and expense, design, install, or cause the design and installation of the transmission or distribution facilities (including all apparatus and necessary protective devices) on its side of the Point of Interconnection, so as to reasonably minimize the likelihood of voltage and frequency abnormalities, originating in the system of one Party, from affecting or impairing the system of the other Party, or other systems to which the system of such Party is interconnected. The Parties agree that all Points of Interconnection will be established and maintained in conformance with the ERCOT Requirements. The Parties agree to cause their systems to be constructed in accordance with specifications at least equal to those provided by the National Electrical Safety Code, approved by the American National Standards Institute, in effect at the time of construction. Except as otherwise provided in the Facility Schedules, each Party will be responsible for the equipment and facilities it owns on its side of the Point of Interconnection.

4.5 From time to time, a Point of Interconnection may be added, changed, modified, or deleted from this Agreement as mutually agreed by the Parties (not to be unreasonably withheld) and/or as ordered by a regulatory authority having jurisdiction thereof. Any such change, addition, or deletion shall be

recorded in Exhibit A and a Facility Schedule in such a way that the numbering of the other Facility Schedules is not changed.

a) If a new Point of Interconnection is desired, the other Party shall be notified in writing of 1) the need for a new Point of Delivery; 2) the desired location of the new Point of Interconnection; 3) the designation of the new Point of Interconnection; 4) a description of the maximum demand desired; and 5) the date desired for commencement of service. Written notification of a request for a new Point of Interconnection shall be given to the other Party at least twelve (12) months prior to the date on which commencement of service at such Point of Interconnection is desired; however, the other Party may, at its sole option, waive all or part of the twelve (12) month written notification requirement. The other Party will use reasonable efforts to provide an additional Point of Interconnection on the date desired; however, the Parties recognize that completion of the Point of Interconnection by the desired in-service date is contingent upon the other Party's ability to acquire the necessary permits, regulatory approvals, property rights, rights-of-way, material and equipment sufficiently in advance of the desired date for the construction and installation of facilities necessary to provide such service. Each Party will, upon request, promptly provide the other Party with information concerning its operations and facilities needed to facilitate the design and construct the Point of Interconnection.

b) Subject to regulatory approval, if required, either Party may terminate a Point of Interconnection on twelve (12) months advance written notice. Upon termination of a Point of Interconnection, each Party shall discontinue the use of the facilities of the other associated with the use of that Point of Interconnection and shall disconnect from that Point of Interconnection. The Parties agree to use reasonable efforts to coordinate the termination of a Point of Interconnection to minimize any disruption in service by either Party. Notwithstanding the foregoing, if Company serves such notice of termination and Cooperative reasonably determines that the continued interconnection of its facilities to the facilities of the Company is needed to provide continuous and adequate service to its customers, the procedures set forth in Section 1.2 of this Agreement shall apply.

4.6 Subject to regulatory approval, if required, unless mutually agreed, no Party shall have the right to disconnect from the other Party at any Point of Interconnection specified on Exhibit A and a Facility Schedule, originally attached to this Agreement or added subsequent to the execution of this Agreement, except as set forth in Section 4.5 above, or for reason of a material violation of the terms of this Agreement, for which opportunity to correct such violation was given under Section 15.1 of this Agreement and such violation was not corrected in accordance with said Section 15.1.

4.7 For facilities not specified in the Facility Schedules, or if a Party makes equipment changes or additions to the equipment at a Point of Interconnection, which may affect the operation or performance of the other Party's interconnection facilities, each Party agrees to notify the other Party, in writing, of such changes. Such changes shall be made in accordance with Good Utility Practice, ERCOT Requirements, the National Electrical Safety Code, and other applicable codes, and standards in effect at the time of construction, and shall be coordinated between the Parties.

4.8 Each Party agrees to provide current as-built drawings to the other Party of the facilities owned by that Party at each Point of Interconnection.

4.9 The Parties agree to coordinate and cooperate on assessments of the reliability impacts to the interconnected transmission system for new facilities requesting connection to their distribution or transmission facilities, in accordance with the NERC Reliability Standards.

4.10 Except as otherwise provided in a Facilities Schedule, each Party will pay for its own interconnection facilities and recover such costs pursuant to such Party's transmission and/or distribution service tariff(s).

4.11 If Cooperative requests a new Point of Interconnection and later cancels its request for this Point of Interconnection prior to the time the Point of Interconnection is placed in service, Cooperative agrees to pay the actual installed costs incurred and committed to be incurred by the Company, and the actual costs of removal of the Company's material and equipment. The total installed cost of the Company's facilities will be provided in the Facilities Schedule. Cooperative shall have the right to take delivery of and pay for any materials ordered but not installed provided such right shall expire if not exercised within ten (10) days after receipt of notice from the Company; and provided further that such right shall be subject to the consent of affected vendors.

4.12 If Cooperative terminates and discontinues the use of an energized Point of Interconnection in accordance with Section 4.5 hereinabove, and as a result of such termination and discontinuation of use the Company facilities that comprise the Point of Interconnection are no longer energized or the costs of such facilities are no longer recoverable, Cooperative shall pay Company the depreciated book value plus removal cost less salvage value of such facilities, or Cooperative may purchase such facilities at depreciated book value provided Cooperative removes or otherwise disconnects such facilities from a direct connection to the Company system.

4.13 If an energized Point of Interconnection is terminated in response to a default by Cooperative in accordance with Article 15 hereinbelow, and as a result of such termination, the cost of facilities that comprise the Point of Interconnection are no longer energized or the costs of such facilities are no longer recoverable, Cooperative shall pay Company the depreciated book value plus removal cost less salvage value of such facilities, or Cooperative may purchase such facilities at depreciated book value provided Cooperative removes or otherwise disconnects such facilities from a direct connection to the Company system.

ARTICLE V - OTHER SERVICES

5.1 This Agreement is applicable only to the interconnection of the facilities of the Parties at the Points of Interconnection and does not obligate either Party to provide, or entitle either Party to receive, any service not expressly provided for herein. Each Party is responsible for making the arrangements necessary to receive any other service that either Party may desire from the other Party or any third party.

5.2 All transmission, transformation, distribution, metering, operations, and maintenance, engineering, billing or other miscellaneous services will be provided and charged under agreements separate from this Agreement.

ARTICLE VI - SYSTEM OPERATION AND MAINTENANCE

6.1 Unless otherwise provided by the Facility Schedules, each Party shall, at each Point of Interconnection, at its own risk and expense, operate and maintain the facilities (including all apparatus and necessary protective devices) it owns or hereafter may own, so as to reasonably minimize the likelihood of voltage and frequency abnormalities, originating in the system of one Party, from affecting or impairing the system of the other Party, or other systems to which the Party is interconnected. The Parties agree that all Points of Interconnection will be operated and maintained in conformance with the ERCOT Requirements.

6.2 Unless otherwise provided by the Facility Schedules, each Party will be responsible for the operation, maintenance and inspection of all facilities it owns now or hereafter may own associated with each Point of Interconnection.

6.3 Unless otherwise provided by the Facility Schedules, each Party shall operate the facilities within its transmission network. The operation of the electrical network shall be such that power flows that enter and exit one Party's transmission facilities do not have undue impacts on another Party's transmission facilities. Operational responsibility for facilities owned by a Party, but installed in the other Party's substation or transmission line, will be identified in the Facility Schedule for that particular Point of Interconnection.

6.4 During the term of this Agreement, the Parties will, consistent with maintaining good operating practices, coordinate their operations to maintain continuity of services to their respective customers to the extent practicable. Planned facility maintenance by either Party that will cause a deviation from the normal power and energy flow at a Point of Interconnection will be scheduled at a mutually agreeable time. Except as otherwise permitted by the terms of this Agreement, no changes will be made in the normal operation of a Point of Interconnection without the mutual agreement of the Parties. The Parties will, to the extent necessary to support continuity of operations, coordinate the operation of protective devices on the facilities they operate in the proximity of the Points of Interconnection that might reasonably be expected to affect the operation of facilities on the other Party's system.

6.5 Each Party will provide the reactive requirements for its own system in accordance with the ERCOT Requirements. Each Party will provide the reactive requirements for its own system so as not to impose a burden on the other Party's system.

6.6 During periods of emergency conditions declared by ERCOT, or as necessary to restore customer service, either Party may operate equipment that is normally operated by the other Party, provided the authorization to do so must first be received from the Party that normally operates the equipment, such authorization not to be unreasonably withheld or delayed. It shall be considered reasonable for the Party that normally operates such equipment to deny such a request by the other Party if the withholding Party will provide such operation within the time frame called for in the circumstances. Such operations by the other Party will be at no cost to the owner or normal operator of the equipment.

6.7 Each Party will determine the operating limits of the facilities that it owns and make such limits known to the Party operating those facilities. The Party operating those facilities will not exceed those limits without prior approval of the Party owning the facilities.

ARTICLE VII - RIGHT OF ACCESS, EQUIPMENT INSTALLATION AND REMOVAL

7.1 Each Party shall permit duly authorized representatives and employees of the other Party to enter upon its premises for the purpose of inspecting, testing, repairing, renewing, or exchanging any or all of the equipment owned by such other Party that is located on such premises or for the purpose of performing any work necessary in the performance of this Agreement.

7.2 Each Party grants to the other Party permission to install, maintain, and/or operate, or cause to be installed, maintained, and/or operated, on its premises, the necessary equipment, apparatus, and devices required for the performance of this Agreement. Any such installation, maintenance, and operation to be performed, except in the case of emergencies, shall be performed only after a schedule of such activity has been submitted and agreed upon by the Parties.

7.3 Any and all equipment, apparatus, and devices placed or installed, or caused to be placed or installed by one Party on, or in, the premises of the other Party, shall be and remain the property of the Party owning and installing such equipment, apparatus, devices, or facilities, regardless of the mode and manner of annexation or attachment to real property. Upon the termination of any Point of Interconnection under this Agreement, the Party owning and installing such equipment, apparatus, devices, or facilities on the property of the other Party, shall 1) have the right to sell such equipment, apparatus, devices, or facilities to the other Party if the other Party wishes to purchase such equipment, apparatus, devices, or facilities or 2) to enter the premises of the other Party and, within a reasonable time, remove such equipment, apparatus, devices, or facilities, at no cost to the owner of the premises. If, upon the termination of any Point of Interconnection under this Agreement, equipment of a Party that is installed on the premises of the other Party is neither sold to the other Party nor removed by the owning Party within a reasonable time, it shall be considered abandoned by the owning Party and may be disposed of by the other Party in the manner it shall determine appropriate; provided, however, that any net cost incurred by the disposing Party shall be reimbursed by the abandoning Party.

7.4 Each Party shall clearly mark its respective equipment, apparatus, devices, or facilities with appropriate ownership identification.

7.5 Either Party may request the other Party to upgrade or modify its terminal facilities at a Point of Interconnection in accordance with the requesting Party's standard design of equipment, provided that the upgrade or modification is consistent with good utility practice and, if applicable, is approved by ERCOT. The requesting Party shall provide the responsive Party a minimum of twenty-four (24) months notice of the upgrade or modification of its terminal facilities at a Point of Interconnection, absent mutual acceptance of a shorter notice period. The Parties agree to use reasonable efforts to coordinate the upgrade or modification of terminal facilities at a Point of Interconnection to minimize any disruption in service.

ARTICLE VIII - METERING AND RECORDS

8.1 All metering equipment required herein shall be selected, installed, tested, operated, and maintained by the Party owning such metering equipment in accordance with Good Utility Practice and the ERCOT Requirements.

8.2 The non-owning Party of the metering equipment shall be permitted to witness any testing, inspection, maintenance, or alteration of such metering equipment owned by the other Party. The owner of such equipment shall give reasonable advance notice of all tests and inspections so that representatives of the other Party may be present. After proper notification to the other Party, the owner may proceed with the scheduled tests or inspections regardless of whether a witness is present.

8.3 If any test or inspection of metering equipment shows that it does not meet the accuracy requirements established by the ERCOT Requirements, the meter or other equipment found to be inaccurate or defective shall be promptly repaired, adjusted, or replaced by the owner. Should metering equipment fail to register, the power and energy delivered and received shall be determined in accordance with the ERCOT Requirements.

8.4 As long as metering, telemetering or communications facilities are required by the ERCOT Requirements and are operated and maintained in accordance with ERCOT guidelines and Protocols, the Party owning these facilities shall allow the other Party to read the meter by means of the existing telemetering and communications facilities. The other Party shall be responsible for any incremental costs incurred by the owning Party to provide any meter reading capability over and above that which is required by the owning Party.

ARTICLE IX – COMMUNICATION AND TELEMETERING FACILITIES

9.1 Each Party shall provide, at its own expense, the necessary communication and telemetering facilities needed for the control and operation of its transmission and/or distribution system.

9.2 All communication and telemetering facilities required herein shall be selected, installed, tested, operated, and maintained by the Party owning such equipment in accordance with Good Utility Practice and the ERCOT Requirements.

ARTICLE X - INDEMNIFICATION

EACH PARTY SHALL ASSUME ALL LIABILITY FOR, AND SHALL INDEMNIFY, DEFEND, AND SAVE HARMLESS THE OTHER PARTY, ITS DIRECTORS, OFFICERS, AND AGENTS (INCLUDING, BUT NOT LIMITED TO, DIRECTORS, OFFICERS, AND EMPLOYEES OF ITS AFFILIATES AND CONTRACTORS) FROM ANY AND ALL DAMAGES, LOSSES, CLAIMS, INCLUDING CLAIMS AND ACTIONS RELATING TO INJURY TO OR DEATH OF ANY PERSON (INCLUDING THE EMPLOYEES OF THE INDEMNIFIED PARTY) OR DAMAGE TO PROPERTY (INCLUDING PROPERTY OF THE INDEMNIFIED PARTY)

DEMANDS, SUITS, RECOVERIES, COSTS AND EXPENSES, COURT COSTS, ATTORNEY FEES, AND ALL OTHER OBLIGATIONS BY OR TO THIRD PARTIES, ARISING OUT OF OR RESULTING FROM NEGLIGENCE OR OTHER FAULT IN THE DESIGN, CONSTRUCTION, OR OPERATION OF THEIR RESPECTIVE FACILITIES, DURING THE PERFORMANCE OF THIS AGREEMENT AND TO THE EXTENT PERMITTED BY LAW, EXCEPT IN CASES OF NEGLIGENCE OR INTENTIONAL WRONGDOING BY THE INDEMNIFIED PARTY.

ARTICLE XI - NOTICES

11.1 Notices of an administrative nature, including but not limited to a notice of termination, notice of default, request for amendment, change to a Point of Interconnection, or request for a new Point of Interconnection, shall be forwarded to the designees listed below for each Party and shall be deemed properly given if delivered in writing to the following:

If to Company:

American Electric Power Service Corporation
Director, System Interconnections
Robert Pennybaker
212 East Sixth Street
Tulsa, OK 74119
918-599-2723
rlpennybaker@aep.com

With copy to:

American Electric Power Service Corporation
Manager, Transmission Customer Engagement
212 East Sixth Street
Tulsa, OK 74119
naward@aep.com

If to Taylor:

Taylor Electric Cooperative, Inc.
President and CEO
Ryan Bartlett
P.O. Box 250
Merkel, TX 79536-0250
226 County Road 287
Building A
Merkel, TX 79536
325-793-8500
Ryan.Bartlett@taylorelectric.com

If to Golden Spread:

Golden Spread Electric Cooperative, Inc.
Kari Hollandsworth
President and Chief Executive Officer
P.O. Box 9898
Amarillo, TX 79105-5898
806-379-7766

11.2 The above listed names, titles, and addresses of either Party may be changed by written notification to the other signatories.

ARTICLE XII - SUCCESSORS AND ASSIGNS

12.1 Subject to the provisions of Section 12.2 below, this Agreement shall be binding upon and inure to the benefit of the permitted successors and assigns of the respective Parties.

12.2 No Party shall assign its interest in this Agreement in whole or in part without the prior written consent of the other Party. Such consent shall not be unreasonably withheld, provided that no Party will be required to consent to any assignment which would, in its sole judgment and among other reasons, subject it to additional federal or state regulation, result in the imposition of additional costs of administration which the Party requesting consent to assignment does not agree to reimburse, or in any way diminish the reliability of its system, enlarge its obligations or otherwise create or maintain an unacceptable condition. The respective obligations of the Parties under this Agreement may not be changed, modified, amended, or enlarged, in whole or in part, by reason of the sale, merger, or other business combination of either Party with any other person or entity. Notwithstanding the foregoing, a Party may assign, without the consent of the other Party, its interest in this Agreement, in whole or in part, to a successor to all or a substantial portion of the Party's transmission and distribution business; to any affiliate of the assigning Party with an equal or greater credit rating; to any transmission service provider with the legal authority and operational ability to satisfy the obligations of the assigning Party under this Agreement; or for collateral security purposes in connection with any financing or financial arrangements. In the event that a Party transfers its interest in this Agreement, in whole or in part, to an affiliate of the assigning Party and such affiliate assignee is not subject to FERC jurisdiction, such affiliate assignee shall negotiate with the other Party any changes needed to protect the rights of the non-assigning Party pursuant to this Agreement and to conform to applicable state regulations and, if agreement is not achieved, file the agreement on an unexecuted basis with the applicable state regulatory authority for approval.

12.3 The several provisions of this Agreement are not intended to and shall not create rights of any character whatsoever in favor of any persons, corporations, or associations other than the Parties to this Agreement, and the obligations herein assumed are solely for the use and benefit of the Parties to this Agreement.

ARTICLE XIII - GOVERNING LAW AND REGULATION

13.1 This Agreement must in all respects be governed by, interpreted, construed, and enforced in accordance with the laws of the State of Texas except as to matters exclusively controlled by the Constitution and statutes of the United States of America. This Agreement is subject to all valid applicable federal, state, and local laws, ordinances, rules and regulations of duly constituted regulatory authorities having jurisdiction.

13.2 This Agreement and all obligations hereunder, are expressly conditioned upon obtaining approval or authorization or acceptance for filing by any regulatory authority whose approval, authorization, or acceptance for filing is required by law. After execution by the Parties, the Company will file this Agreement with the FERC with copies of such filing provided to the PUCT. The Parties hereby agree to support the approval of this Agreement before such regulatory authorities and to provide such documents, information, and opinions as may be reasonably required or requested by either Party in the course of approval proceedings.

13.3 In the event that a regulatory authority having jurisdiction over this Agreement orders a change in the terms of this Agreement, the Parties agree to negotiate in good faith a replacement term that will most nearly accomplish the purpose and intent of the original term consistent with the regulatory order. If the Parties cannot reach an agreement over the new term, and if the old term is an essential provision of this Agreement, either Party may elect to terminate this Agreement by providing sixty (60) days prior written notice of such election to the other Party. An election to terminate under this provision shall not affect either Party's duty to perform prior to the effective date of termination. Notwithstanding the foregoing, if Company serves such notice of termination and Cooperative notifies Company that the continued interconnection to Company facilities is needed to assure the reliable supply of electric service to retail load, the procedures set forth in Section 1.2 of this Agreement shall apply.

13.4 In the event any part of this Agreement is declared invalid by a court of competent jurisdiction, the remainder of this Agreement shall remain in full force and effect and shall constitute a binding agreement between the Parties provided, however, that if either Party determines, in its sole discretion, that there is a material change in this Agreement by reason of any provision or application being finally determined to be invalid, illegal, or unenforceable, the Parties shall negotiate in good faith to establish such substitute provisions as will eliminate such material adverse effect to the extent practicable.

ARTICLE XIV – DEFAULT AND FORCE MAJEURE

Neither Party shall be considered in default with respect to any obligation hereunder, other than the payment of money, if prevented from fulfilling such obligations by reason of any cause beyond its reasonable control, including, but not limited to, outages or interruptions due to weather, accidents, equipment failures or threat of failure, strikes, civil unrest, injunctions or order of governmental or regulatory authority having jurisdiction ("Force Majeure"). If performance by either Party has been prevented by such event, the affected Party shall promptly notify the other Party of the existence, nature and expected duration of the event, and shall promptly and diligently attempt to remove the cause of its failure to perform, except that neither Party shall be obligated to agree to any quick settlement of any strike

or labor disturbance, that, in the affected Party's opinion, may be inadvisable or detrimental, or to appeal from any administrative or judicial ruling.

ARTICLE XV - TERMINATION ON DEFAULT

15.1 The term “Default” shall mean the failure of either Party to perform any material obligation in the time or manner provided in this Agreement. No Default shall exist where such failure to discharge an obligation (other than the payment of money) is the result of Force Majeure as defined in this Agreement or the result of an act or omission of the other Party. Upon a Default, the non-defaulting Party shall give written notice of such Default to the defaulting Party. Except as provided in Section 15.2, the defaulting Party shall have thirty (30) days from receipt of the Default notice within which to cure such Default; provided however, if such Default is not capable of cure within thirty (30) days, the defaulting Party shall commence such cure within thirty (30) days after notice and continuously and diligently complete such cure within ninety (90) days from receipt of the Default notice; and, if cured within such time, the Default specified in such notice shall cease to exist.

15.2 If a Default is not cured as provided in this Article, or if a Default is not capable of being cured within the period provided for herein, the non-defaulting Party shall have the right to terminate this Agreement by written notice at any time until cure occurs, and be relieved of any further obligation hereunder and, whether or not that Party terminates this Agreement, to recover from the defaulting Party all amounts due hereunder, plus all other damages and remedies to which it is entitled at law or in equity. The provisions of this Section will survive termination of this Agreement.

15.3 The failure of a Party to this Agreement to insist, on any occasion, upon strict performance of this Agreement will not be considered to waive the obligations, rights, or duties imposed upon the Parties by this Agreement.

ARTICLE XVI – MISCELLANEOUS PROVISIONS

16.1 Any undertaking by a Party to the other Party under this Agreement shall not constitute the dedication of the electrical system or any portion thereof of that Party to the public or to the other Party, and it is understood and agreed that any such undertaking shall cease upon the termination of this Agreement.

16.2 IN NO EVENT SHALL EITHER PARTY BE LIABLE UNDER ANY PROVISION OF THIS AGREEMENT FOR ANY LOSSES, DAMAGES, COSTS OR EXPENSES FOR ANY SPECIAL, INDIRECT, INCIDENTAL, CONSEQUENTIAL, OR PUNITIVE DAMAGES, INCLUDING BUT NOT LIMITED TO LOSS OF PROFIT OR REVENUE, LOSS OF THE USE OF EQUIPMENT, COST OF CAPITAL, COST OF TEMPORARY EQUIPMENT OR SERVICES, WHETHER BASED IN WHOLE OR IN PART IN CONTRACT, IN TORT, INCLUDING NEGLIGENCE, STRICT LIABILITY, OR ANY OTHER THEORY OF LIABILITY; PROVIDED, HOWEVER, THAT DAMAGES FOR WHICH A PARTY MAY BE LIABLE TO THE OTHER PARTY UNDER ANOTHER AGREEMENT WILL NOT BE CONSIDERED TO BE SPECIAL, INDIRECT, INCIDENTAL, OR CONSEQUENTIAL DAMAGES HEREUNDER.

16.3 This Agreement shall not affect the obligations or rights of either Party with respect to other agreements. Each Party to this Agreement represents that there is no agreement or other obligation binding upon it, which, as such Party is presently aware, would limit the effectiveness or frustrate the purpose of this Agreement.

16.4 This Agreement may be amended only upon mutual agreement of the Parties, which amendment will not be effective until reduced in writing and executed by the Parties.

16.5 The descriptive headings of the various sections of this Agreement have been inserted for convenience of reference only and are to be afforded no significance in the interpretation or construction of this Agreement.

16.6 This Agreement will be executed in two or more counterparts, each of which is deemed an original, but all constitute one and the same instrument.

16.7 This Agreement constitutes the entire agreement of the Parties relating to the subject matter hereof, and supersedes all prior agreements, including the Original Agreement, and all amendments thereto.

[Signatures are on next page]

IN WITNESS WHEREOF, the Parties have caused this Agreement to be executed by the undersigned authorized representatives.

AEP TEXAS INC.

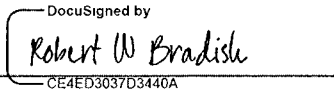
By: 

Robert W. Bradish
Vice President

Date: 9/21/2020 | 9:50 AM EDT

**TAYLOR ELECTRIC
COOPERATIVE, INC.**

By: 
Ryan W Bartlett (DocuSign Envelope ID: 26282929-091C-D3)

Ryan Bartlett
President and CEO

Date: Sep 4, 2020

**GOLDEN SPREAD ELECTRIC
COOPERATIVE, INC.**

By: 

Kari Hollandsworth
President and Chief Executive Officer

Date: 9/14/2020

EXHIBIT "A"

Facility Schedule No.	Point of Interconnection (# of Points) ** denotes GSEC POI	Delivery Voltage [kV]	Meter Voltage [kV]	One-Line Diagram Attached
1	Clyde (1)	12.5	12.5	Y
2	Whitaker (1)** (f/k/a Delk)	69	12.5	Y
3	Denton Valley (1)**	69	12.5	Y
4	Ely (1) **	69	12.5	Y
5 (terminated)	Eula (0)	-	-	-
6	Fort Chadbourne (1)	12.5	12.5	Y
7 (terminated)	Hamby (0)	-	-	-
8 (terminated)	Happy Valley (0)**	-	-	-
9 (terminated)	Lowden (0)	-	-	-
10	Watts ^(a) (1)** (fka Potosi)	138	12.5	Y
11 (terminated)	Roberts (0)**	-	-	-
12	Scott (1)**	69	2.4	Y
13 (terminated)	Scranton 12.5 (0)	-	-	-
14	Sandusky ^(a) (1)** (fka Sharp)	138	12.5	Y
15 (terminated)	Tuscola (0)	-	-	-
16 (terminated)	Kirby (0)	-	-	-
17	Walker (1)**	138	12.5	Y
18	Horton (1)**	138	12.5	Y
19	Church (1)**	138	12.5	Y
20	Valley Creek (1)**	138	138	Y
21	Tomato (1)**	138	138	Y
22	Atwell (1)**	69	12.5	Y

(a) Metering equipment is owned by Cooperative or its designated representative at this Point of Interconnection

FACILITY SCHEDULE NO. 1

1. **Name:** Clyde
2. **Facility Location:** Point of Interconnection is outside of Company's Clyde substation, northwest of Clyde, TX, Callahan County, north side of IH-20.
3. **Voltage at Point of Interconnection:** 12.5 kV
4. **Metered Voltage:** 12.5 kV
5. **Loss Adjustment Due To Meter Location:** None
6. **Normal Operation of Interconnection:** Closed
7. **One-Line Diagram Attached:** Yes
8. **Description of Facilities Installed and Owned by Each Party:**
9. **Operational Responsibilities of Each Party:**
Each Party operates the facilities it owns.
10. **Maintenance Responsibilities of the Parties:**
Each Party maintains the facilities it owns.
11. **Maximum Contract Demand:** 2,100 kW
12. **Other Terms and Conditions:**
Cooperative is to have access to the OCR #5360 and load side disconnect switch #5361

FACILITY SCHEDULE NO. 1 (continued)

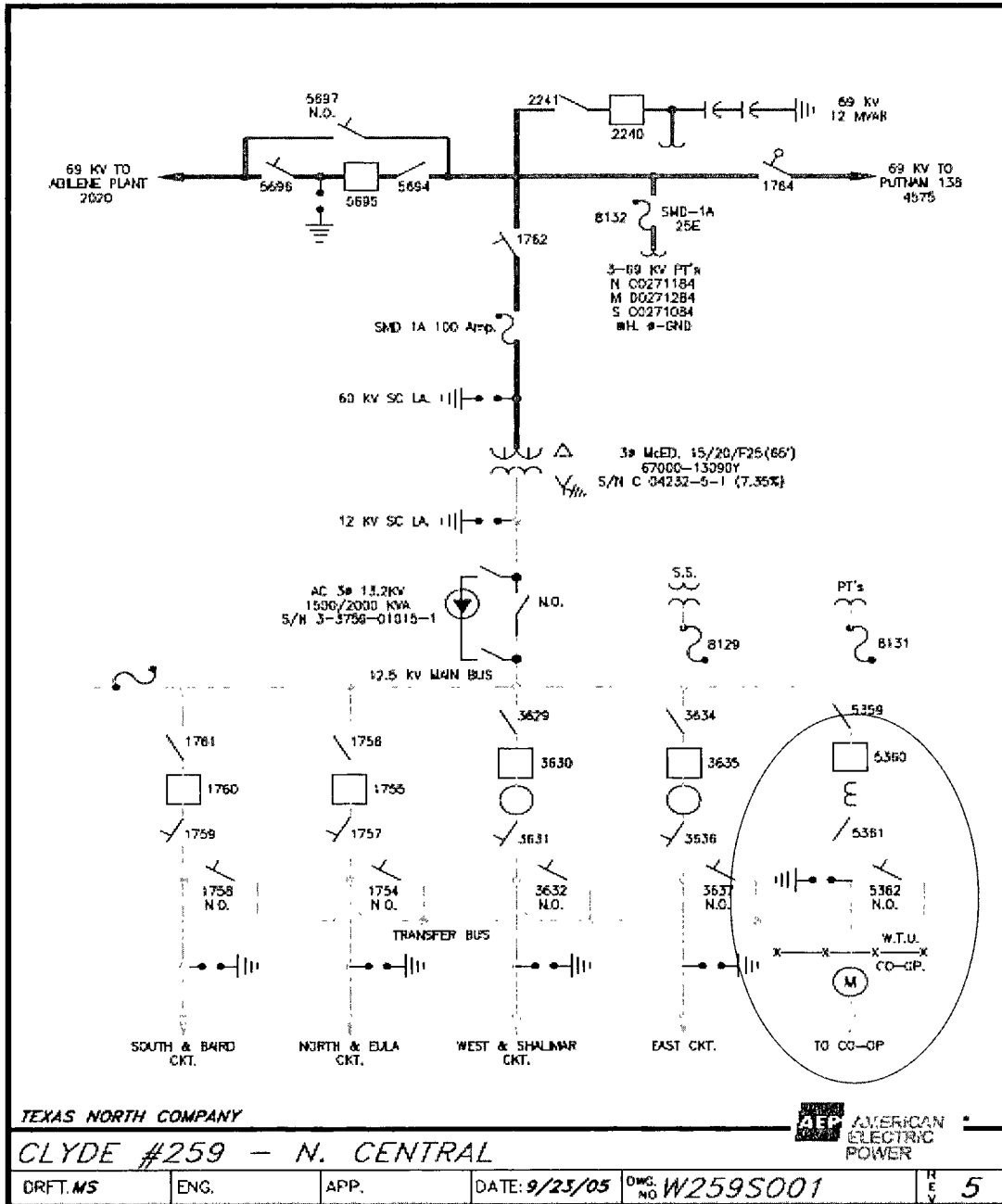

FACILITY SCHEDULE NO. 2

- 1. **Name:** Whitaker (f/n/a Delk) **

- 2. **Facility Location:** The Whitaker Point of Interconnection (“POI”) (32° 34’ 32.04” N., 99° 47’ 39.02” W.) is at the Whitaker tap in Jones County, located approximately 0.25 mile east US 277 on County Road 320, south of Hawley, Texas. More specifically, the POI is where AEP’s jumper conductors physically connect to GSEC’s 69 kV transmission line conductors terminating at AEP’s 69 kV dead-end structure.

- 3. **Delivery Voltage:** 69 kV

- 4. **Metered Voltage:** 12.5 kV

- 5. **Loss Adjustment Due to Meter Location:** None

- 6. **Normal Operation of Interconnection:** Closed

- 7. **One-Line Diagram Attached:** Yes

- 8. **Facilities Ownership and Installation Responsibilities of the Parties:**
 - 8.1. **AEP agrees that it owns the following facilities:**
 - i. The Quint substation and all the facilities in it
 - ii. Approximately 535 feet of 69 kV radial transmission line from the Quint substation to the POI dead-end structure
 - iii. The 69 kV dead-end structure that terminates the radial Quint 69 kV transmission line and GSEC’s radial 69 kV transmission line
 - iv. The jumpers at the dead-end structure that connects GSEC and AEP

 - 8.2. **GSEC agrees that it owns the following facilities:**
 - i. The radial 69 kV transmission line from the Whitaker substation
 - ii. The radial 69 kV in-line switch (2734)

- 9. **Facility Operation Responsibilities of the Parties:**

Each Party will operate the facilities it owns.

- 10. **Facility Maintenance Responsibilities of the Parties:**

Each Party maintains the facilities it owns.

- 11. **Estimated Peak Load:** 4,100 kW

12. Other Terms and Conditions:

12.1 AEP is to have access to GSEC's switch (2734).

12.2 PT & CT sold to Cooperative

[The remainder of this page intentionally left blank]

FACILITY SCHEDULE NO. 2 (continued)
Area Map



FACILITY SCHEDULE NO. 2 (continued)
One Line Diagram

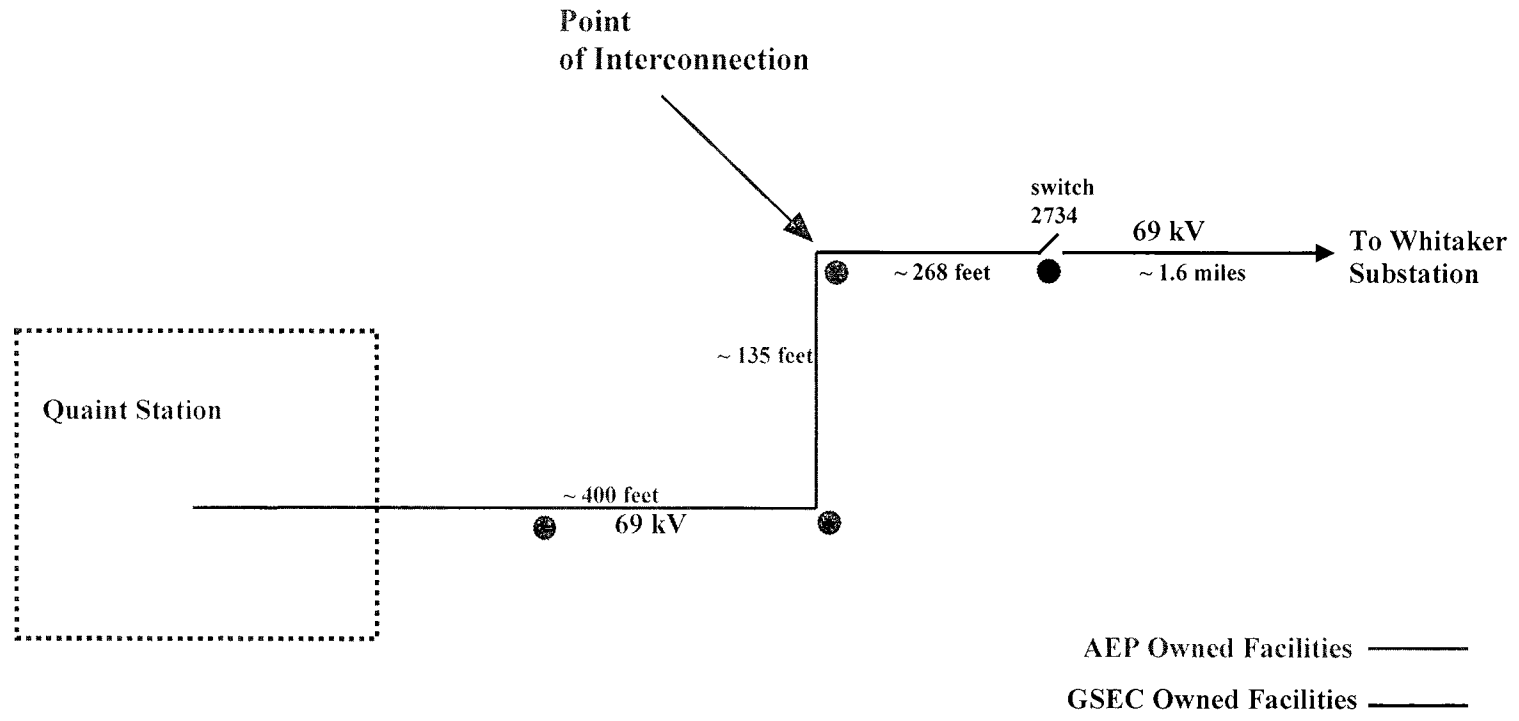

Distances as shown are conceptual and not to scale;
facilities are not shown completely.

FACILITY SCHEDULE NO. 3

1. Name: **Denton Valley**
2. Facility Location: Point of Interconnection is twenty-three (23) miles southeast of Abilene, TX, Callahan County on Highway 36 at the intersection of FM 604 in Cooperative's substation.
3. Voltage at Point of Interconnection: 69.0 kV
4. Metered Voltage: 12.5 kV
5. Loss Adjustment Due To Meter Location: No
6. Normal Operation of Interconnection: Closed
7. One-Line Diagram Attached: Yes
8. Description of Facilities Installed and Owned by Each Party:
9. Operation Responsibilities of Each Party:
 - Each Party operates the facilities it owns.
10. Maintenance Responsibilities of Each Party:
 - Each Party maintains the facilities it owns.
11. Maximum Contract Demand: 5,000 kW
12. Other Terms and Conditions:
 - Company is to have access to Cooperative's switch #5313
 - PT & CT sold to Cooperative

FACILITY SCHEDULE NO. 3 (continued)

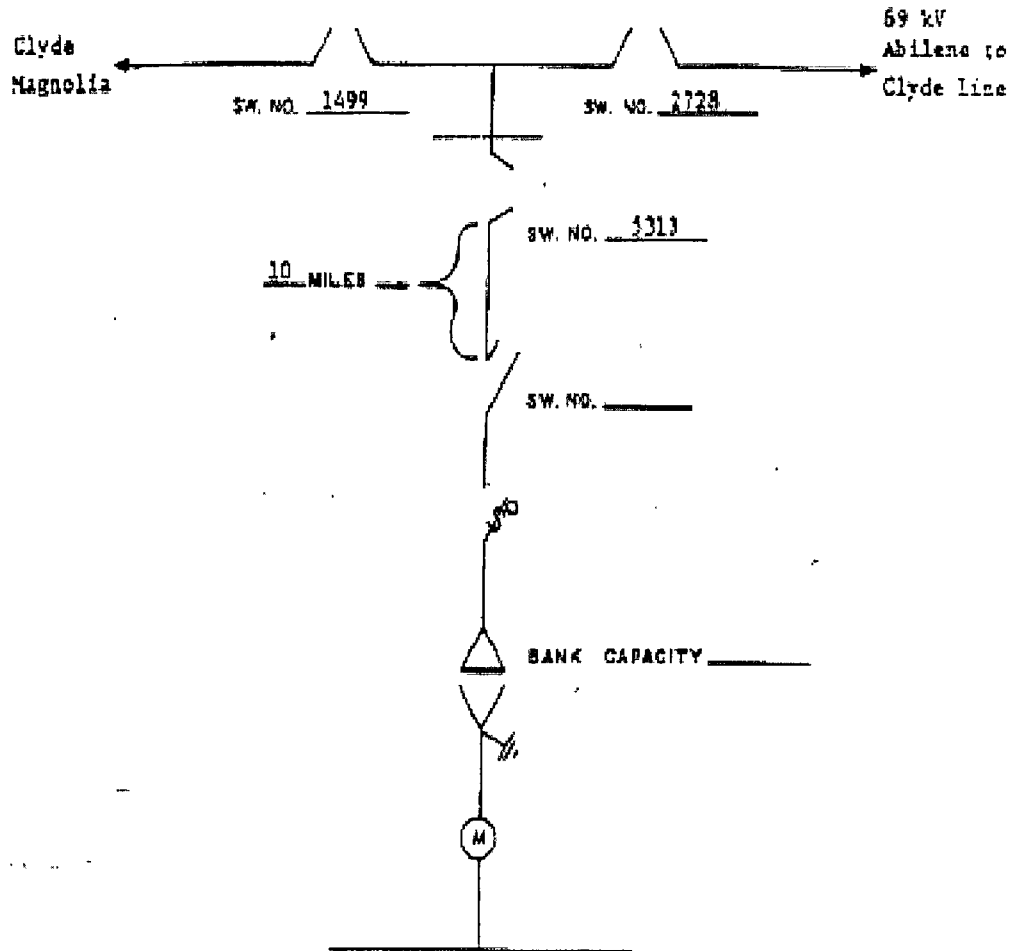

1. West Texas Utilities Co. is to have access to the Taylor Electric Cooperative switch indicated above as switch 3313.
2. Dashed line indicates change of ownership.

COOPERATIVE	METER POINT NAME
Taylor Electric Cooperative, Inc.	Denton Valley

FACILITY SCHEDULE NO. 4

1. **Name:** Ely**
2. **Facility Location:** The Ely Point of Interconnection (“POI”) is located in Taylor County, approximately 5 miles east of Merkel, Texas, on east side of Wells Lane/County Road 412, approximately 0.5 miles south of County Road 410. More specifically, the POI is where AEP’s jumper conductors physically connect to GSEC’s 69 kV transmission line conductors terminating at AEP’s Capella Station (“AEP Station”).
3. **Delivery Voltage:** 69 kV
4. **Metered Voltage:** 12.5 kV
5. **Loss Adjustment Due To Meter Location:** No
6. **Normal Operation of Interconnection:** Closed
7. **One-Line Diagram Attached:** Yes
8. **Facilities Ownership and Installation Responsibilities of the Parties:**
 - 8.1. **AEP agrees that it owns the following facilities:**
 - i. The AEP Station and all the facilities within it, except the facilities in Section 8.2(i) below
 - ii. The Northwest Abilene 69 kV transmission line that terminates at the AEP Station
 - iii. The Merkel 69 kV transmission line that terminates at the AEP Station
 - iv. The jumpers from the AEP Station to GSEC’s 69 kV transmission line
 - 8.2. **GSEC agrees that it owns the following facilities:**
 - i. The radial Ely 69 kV transmission line that terminates at the AEP Station
 - ii. The radial 69 kV in-line switch (2788)
9. **Facility Operation Responsibilities of the Parties:**

Each Party will operate the facilities it owns.
10. **Facility Maintenance Responsibilities of the Parties:**

Each Party will maintain the facilities it owns.
11. **Estimated Peak Load:** 9,200 kW

12. Other Terms and Conditions:

- 12.1. AEP is to have access to Cooperative's switch (2788)
- 12.2. PT & CT sold to Cooperative

[The remainder of this page intentionally left blank]

FACILITY SCHEDULE NO. 4 (continued)
Area Map

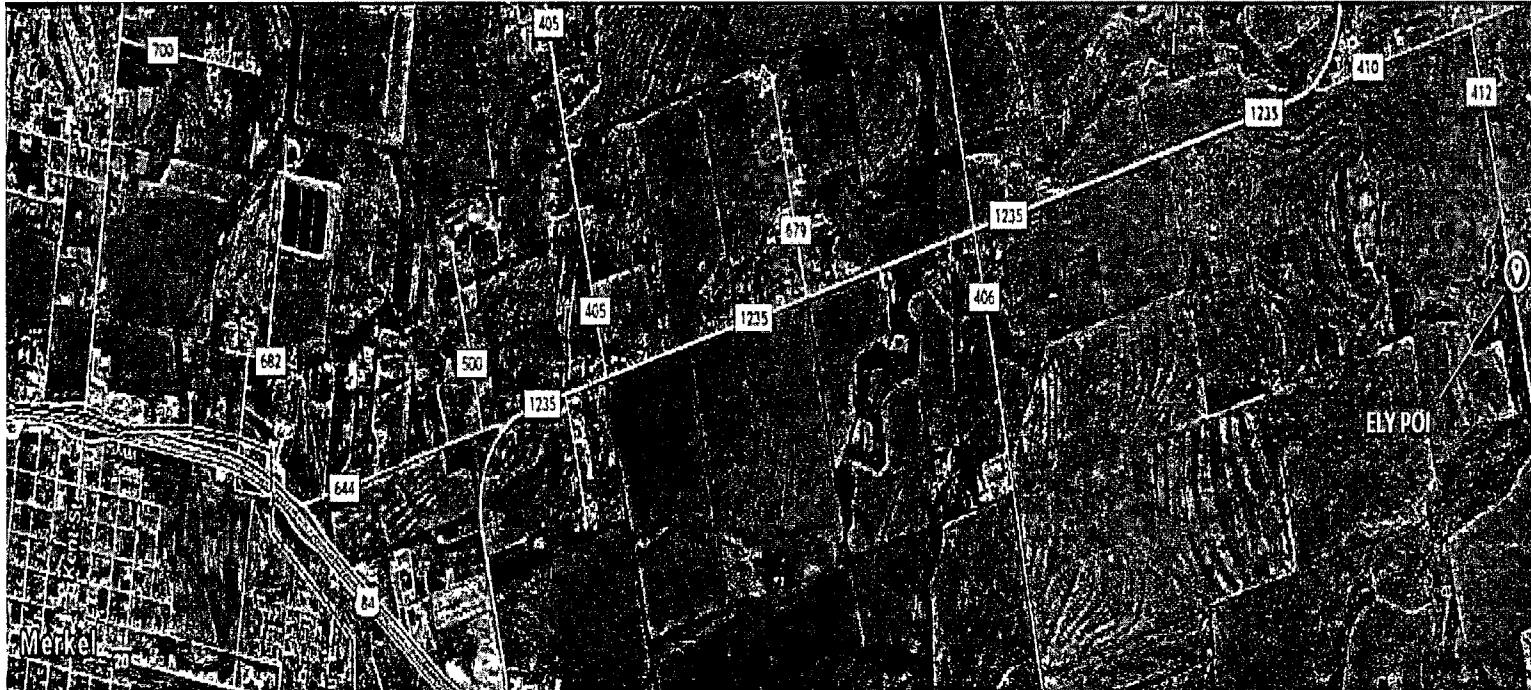

FACILITY SCHEDULE NO. 4 (continued)
One Line Diagram

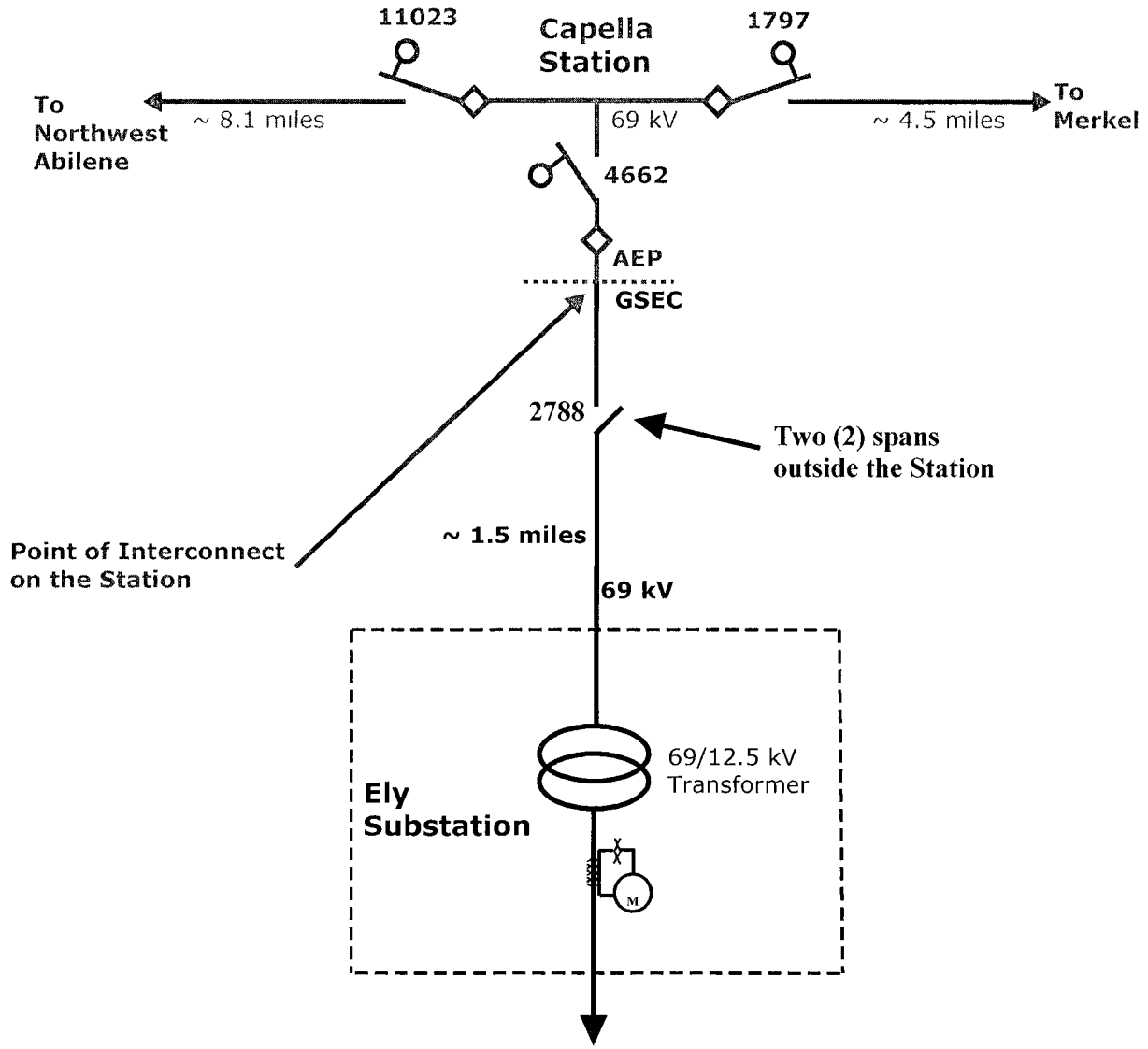

————— AEP Facilities
————— GSEC Facilities

Distances as shown are conceptual and not to scale;
facilities are not shown completely.

FACILITY SCHEDULE NO. 5

Eula

TERMINATED

[The remainder of this page intentionally left blank]

FACILITY SCHEDULE NO. 6

1. Name: **Fort Chadbourne**

2. Facility Location: Point of Interconnection is approximately 7,800 feet out of Company's Fort Chadbourne substation or one and one tenth (1.1) mile east of State Highway 70 at the south end of the Oak Creek Reservoir Dam, Coke County.

3. Voltage at Point of Interconnection: 12.5 kV

4. Metered Voltage: 12.5 kV

5. Loss Adjustment Due To Meter Location: No

6. Norman Operation of Interconnection: Closed

7. One-Line Diagram Attached: Yes

8. Description of Facilities Installed and Owned by Each Party:

9. Operation Responsibilities of Each Party:
 - Each Party operates the facilities it owns.

10. Maintenance Responsibilities of Each Party:
 - Each Party maintains the facilities it owns.

11. Maximum Contract Demand: 1,000 kW

12. Other Terms and Conditions:
 - Cooperative is to have access to OCR #R94203

FACILITY SCHEDULE NO. 6 (continued)

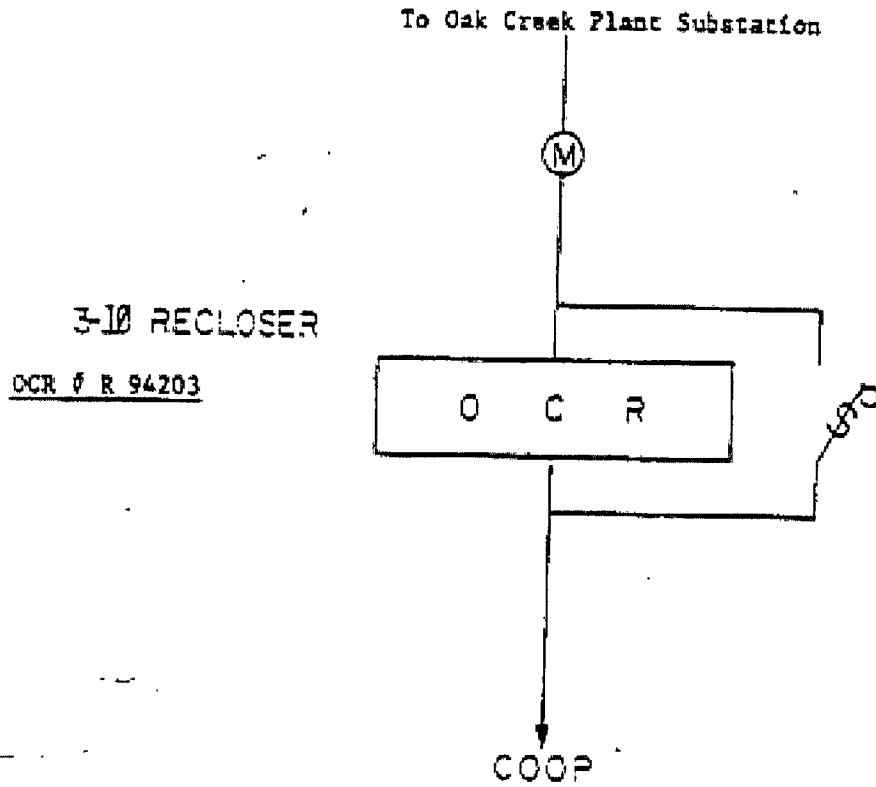

1. Taylor Electric Coop is to have access to OCR # 94203.

COOPERATIVE	METER POINT NAME
Taylor Electric Cooperative, Inc.	Ft. Chadbourne

FACILITY SCHEDULE NO. 7

Hamby

TERMINATED

[The remainder of this page intentionally left blank]

FACILITY SCHEDULE NO. 8

Happy Valley**

TERMINATED

[The remainder of this page intentionally left blank]

FACILITY SCHEDULE NO. 9

Lowden

TERMINATED

[The remainder of this page intentionally left blank]

FACILITY SCHEDULE NO. 10

1. Name: **Potosi**

2. Facility Location: Point of Interconnection is at tap off Company's S. Abilene-Lake Leon 138 kV line 7,260 feet east of Hwy 36, 1,657 feet south of County Road 250. Meter is in Cooperative's substation 1,904 feet east of Hwy 36 on north side of County Road 238.

3. Voltage at Point of Interconnection: 138 kV

4. Metered Voltage: 12.5 kV

5. Loss Adjustment Due To Meter Location: No

6. Normal Operation of Interconnection: Closed

7. One-Line Diagram Attached: Yes

8. Description of Facilities Installed and Owned by Each Party:

9. Operation Responsibilities of Each Party:
 - Each Party operates the facilities it owns.

10. Maintenance Responsibilities of Each Party:
 - Each Party maintains the facilities it owns.

11. Maximum Contract Demand:

12. Other Terms and Conditions:
 - Metering equipment is owned by Cooperative or its designated representative at this Point of Interconnection

FACILITY SCHEDULE NO. 10 (continued)

POTOSI TAP

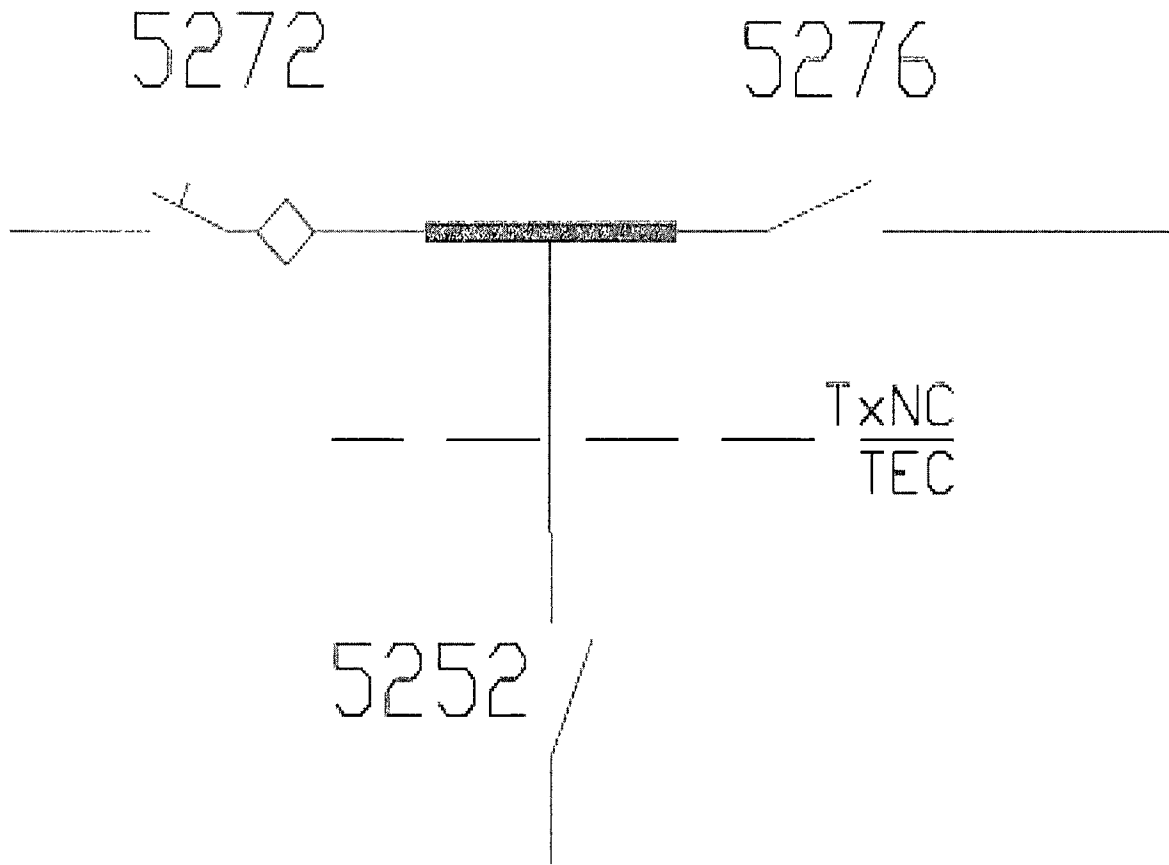

FACILITY SCHEDULE NO. 11

Robert**

TERMINATED

[The remainder of this page intentionally left blank]

FACILITY SCHEDULE NO. 12

1. Name: **Scott**

2. Facility Location: Point of Interconnection is in the Cooperative's 69/2.4 kV substation located two (2) miles south of I-20 half way between Merkel, TX and Trent, TX, Taylor County.

3. Voltage at Point of Interconnection: 69.0 kV
4. Metered Voltage: 2.4 kV
5. Loss Adjustment Due To Meter Location: No
6. Norman Operation of Interconnection: Closed
7. One-Line Diagram Attached: Yes
8. Description of Facilities Installed and Owned by Each Party:
9. Operation Responsibilities of Each Party:
 - Each Party operates the facilities it owns.
10. Maintenance Responsibilities of Each Party:
 - Each Party maintains the facilities it owns.
11. Maximum Contract Demand: 2,300 kW
12. Other Terms and Conditions:
 - Company is to have access to Cooperative switch 5303
 - PT & CT sold to Cooperative

FACILITY SCHEDULE NO. 12 (continued)

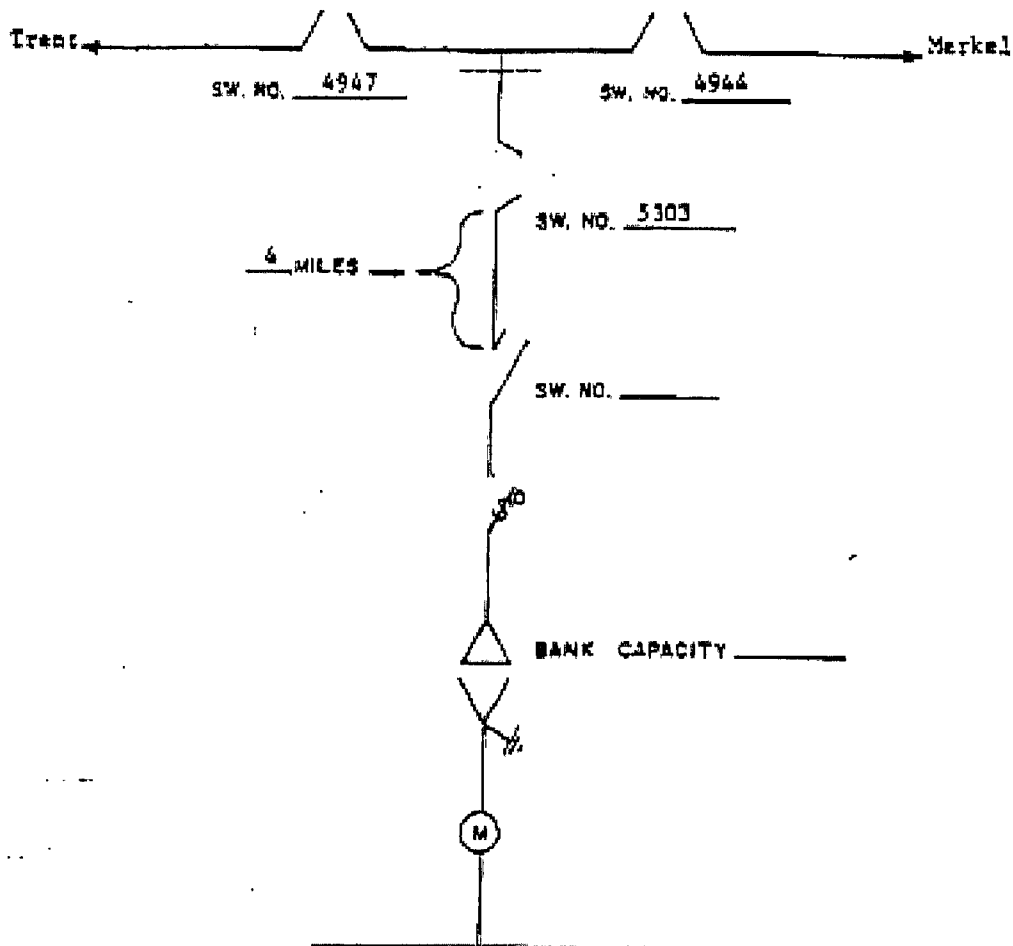

1. West Texas Utilities is to have access to the Taylor Electric Co-op switch indicated above as switch 5301.
2. Dashed line indicates change of ownership.

COOPERATIVE	METER POINT NAME
Taylor Electric Cooperative, Inc.	Scott

FACILITY SCHEDULE NO. 13

Scranton 12.5

TERMINATED

[The remainder of this page intentionally left blank]

FACILITY SCHEDULE NO. 14

1. Name: **Sharp**

2. Facility Location: Point of Interconnection is at tap off Company's S. Abilene-Elm Creek 138 kV line approximately 1,500 feet west of Company's Abilene South Substation near the intersection of Waldrop Lane and US Hwy 83. Meter is in Cooperative's substation less than one span from the tap.

3. Voltage at Point of Interconnection: 138 kV

4. Metered Voltage: 12.5 kV

5. Loss Adjustment Due To Meter Location: No

6. Normal Operation of Interconnection: Closed

7. One-Line Diagram Attached: Yes

8. Description of Facilities Installed and Owned by Each Party:

9. Operation Responsibilities of Each Party:
 - Each Party operates the facilities it owns.

10. Maintenance Responsibilities of Each Party:
 - Each Party maintains the facilities it owns.

11. Maximum Contract Demand:

12. Other Terms and Conditions:
 - Metering equipment is owned by Cooperative or its designated representative at this Point of Interconnection

FACILITY SCHEDULE NO. 14 (continued)

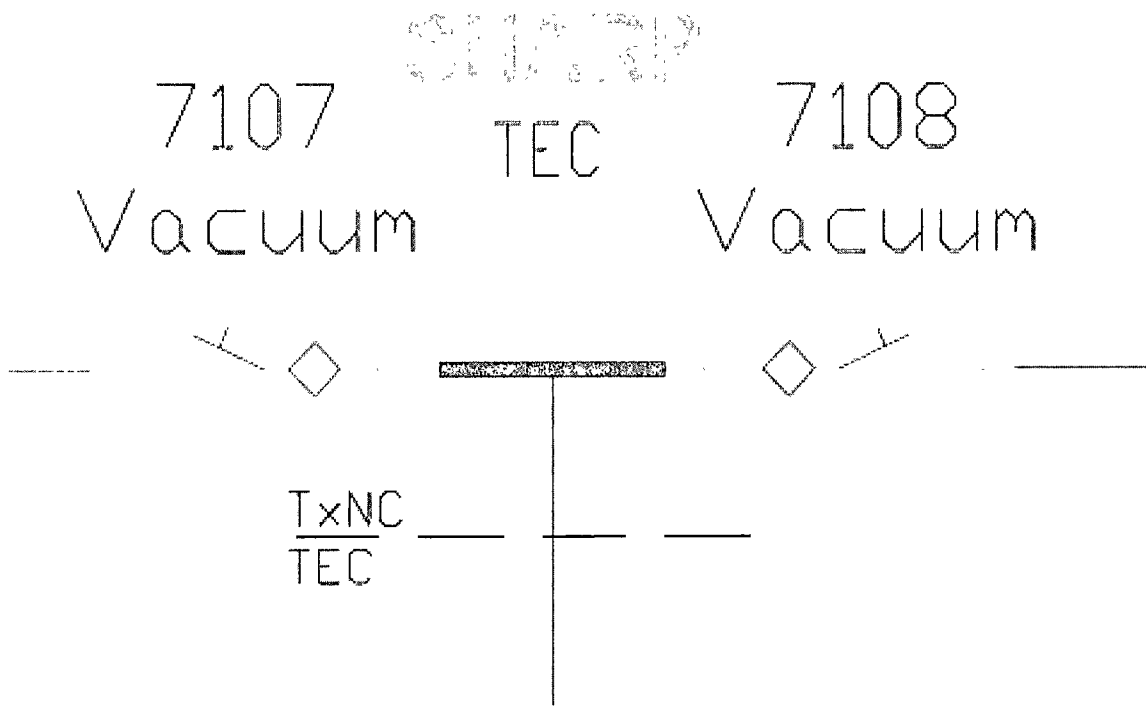

FACILITY SCHEDULE NO. 15

Tuscola

TERMINATED

[The remainder of this page intentionally left blank]

FACILITY SCHEDULE NO. 16

Kirby

TERMINATED

[The remainder of this page intentionally left blank]

FACILITY SCHEDULE NO. 17

1. Name: **Walker**

2. Facility Location: The Point of Interconnection is located in Taylor County, Texas in the city limits of Abilene on the north side of Vinson Road northeast of Vinson Rd and FM 1750. More specifically, the Point of Interconnection is at Golden Spread’s first structure outside of the Company’s 138 kV box bay Vinson Substation (“Substation”) connecting to Company’s South Abilene to Putnam 138 kV transmission line with Company owning the single span of conductors back to the Substation, and Golden Spread owning the structure and remaining conductors to Golden Spread’s distribution substation approximately 400 feet from the Substation.

3. Voltage at Point of Interconnection: 138 kV

4. Metered Voltage 12.5 kV

5. Loss Adjustment Due To Meter Location: Yes

6. Normal Operation of Interconnection: Closed

7. One-Line Diagram Attached: Yes

8. Description of Facilities Installed and Owned by Each Party:
 - A. Company’s Facilities:
 - i. the Substation and all associated facilities, including but not limited to the in-line and radial switches, Substation structures and property, and the first radial span of conductor out of the Substation
 - ii. the 12.5 kV metering facilities

 - B. Golden Spread’s Facilities:
 - i. the first structure outside of Substation and remaining facilities to Golden Spread’s distribution substation
 - ii. isolating protective device within 2 spans of the 138 kV Point of Interconnection
 - iii. SCADA meter in series/parallel with the Company CT’s/PT’s

9. Operational Responsibilities of Each Party:

Each Party controls and operates the facilities it owns.

10. Maintenance Responsibilities of Each Party:

Each Party maintains the facilities it owns.

11. **Maximum Contract Demand:** 24,000 kW

12. **Other Terms and Conditions:** None

FACILITY SCHEDULE NO. 17 (continued)

Area Map

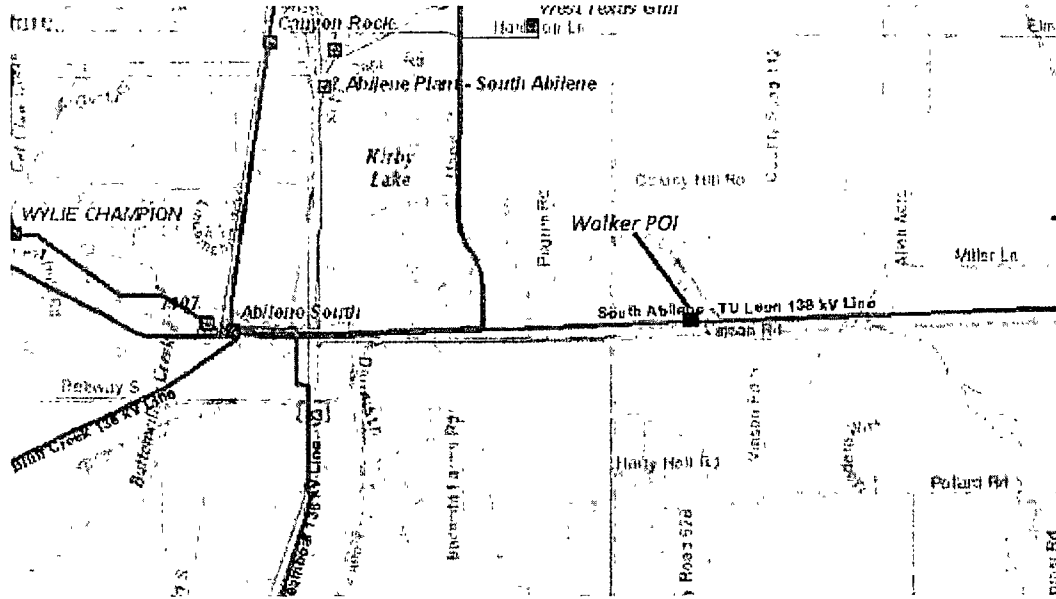

FACILITY SCHEDULE NO. 17 (continued)

Walker Point of Interconnection One Line Diagram

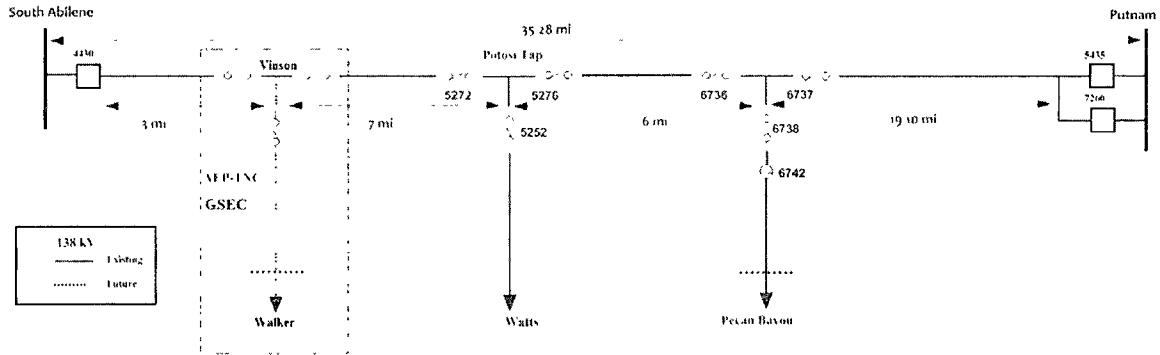

FACILITY SCHEDULE NO. 18

1. Name: **Horton**
2. Facility Location: The Point of Interconnection is located in Taylor County, Texas in the city limits of Abilene near FM 2833 and CR 306. More specifically, the Point of Interconnection is at Golden Spread’s first structure outside of the Company’s 138 kV box bay Neas Substation (“Substation”) with Company owning the single span of conductors back to the Substation, and Golden Spread owning the structure and remaining conductors to Golden Spread’s distribution substation approximately 350 feet from the Substation.
3. Voltage at Point of Interconnection: 138 kV
4. Metered Voltage 12.5 kV
5. Loss Adjustment Due To Meter Location: Yes
6. Normal Operation of Interconnection: Closed
7. One-Line Diagram Attached: Yes
8. Description of Facilities Installed and Owned by Each Party:
 - A. Company’s Facilities:
 - i. the Substation and all associated facilities, including but not limited to the in-line and radial switches, Substation structures and property, and the first radial span of conductor out of the Substation
 - ii. the 12.5 kV metering facilities
 - B. Golden Spread’s Facilities:
 - i. the first structure outside of Substation and remaining facilities to Golden Spread’s distribution substation
 - ii. isolating protective device within 2 spans of the 138 kV Point of Interconnection
 - iii. SCADA meter in series/parallel with the Company CT’s/PT’s
9. Operational Responsibilities of Each Party:

Each Party controls and operates the facilities it owns.
10. Maintenance Responsibilities of Each Party:

Each Party maintains the facilities it owns.

11. **Maximum Contract Demand:** 20,000 kW
12. **Other Terms and Conditions:** None

FACILITY SCHEDULE NO. 18 (continued)

Area Map

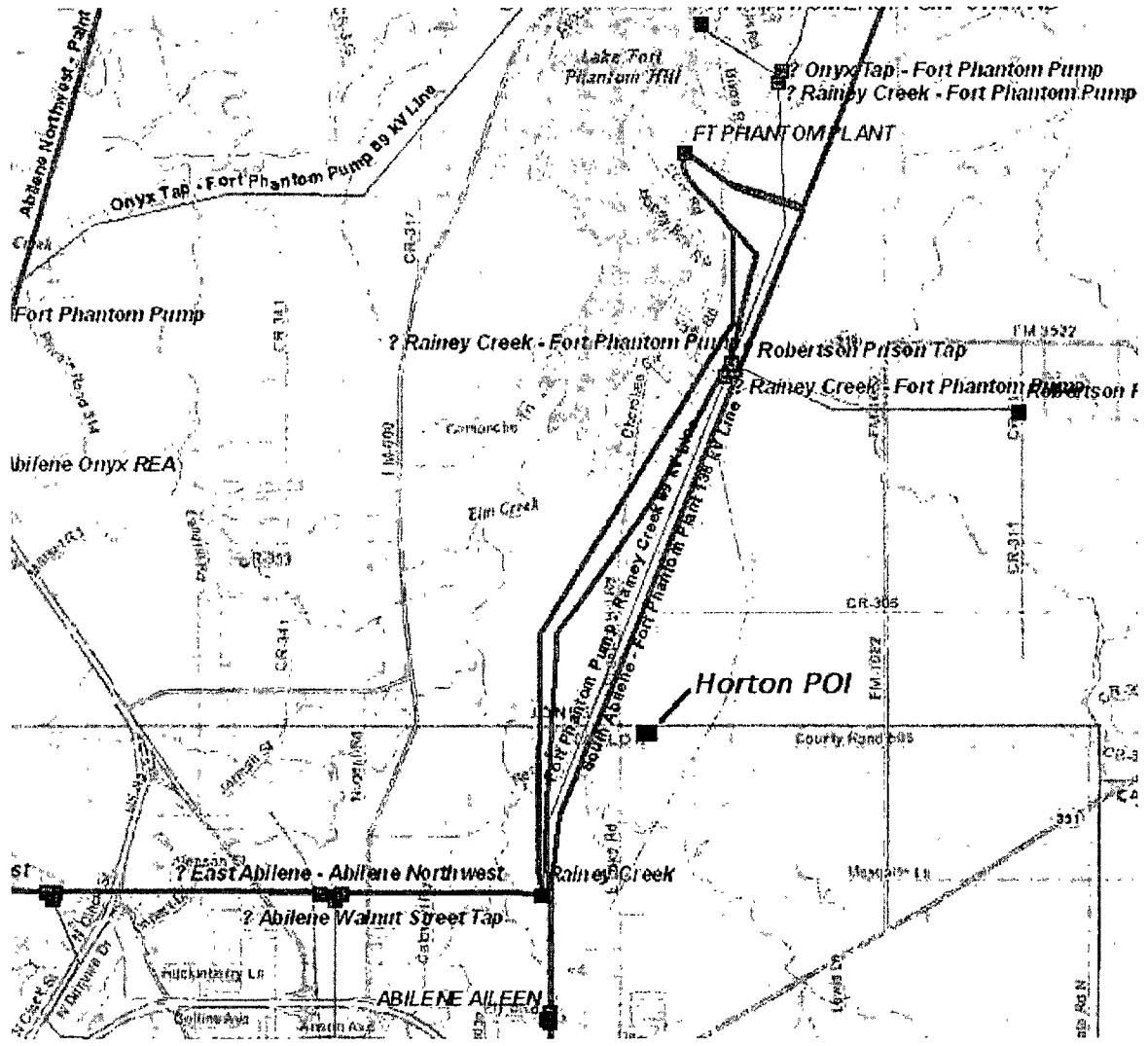

FACILITY SCHEDULE NO. 18 (continued)

Horton Point of Interconnection One Line Diagram

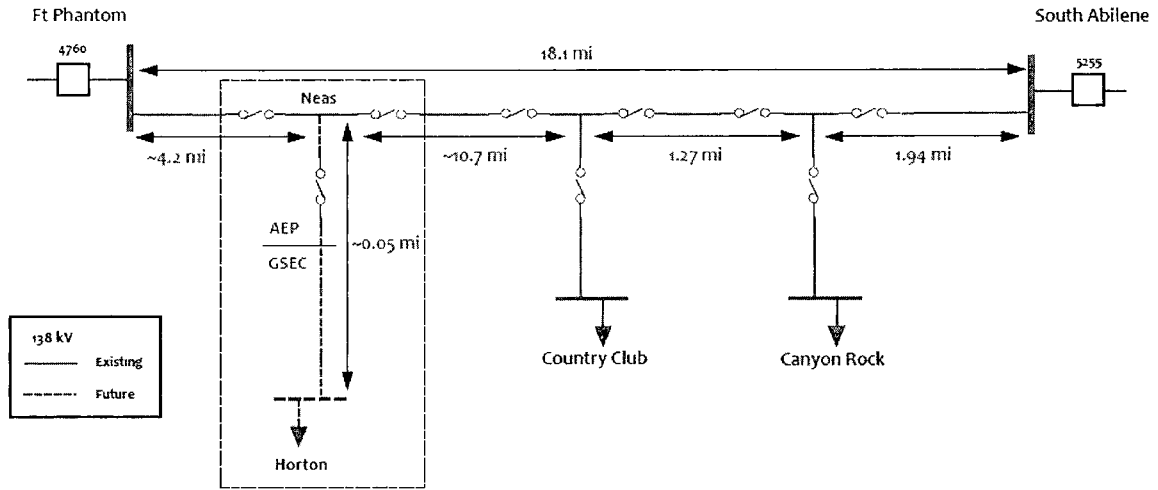

FACILITY SCHEDULE NO. 19

1. Name: **Church**
2. Facility Location: The Point of Interconnection is located in Taylor County, Texas near CR 259 and CR 254. More specifically, the Point of Interconnection is at Golden Spread's first structure outside of the Company's 138 kV box bay Estes Substation ("Substation") with Company owning the single span of conductors back to the Substation, and Cooperative owning the structure and remaining conductors to Golden Spread's distribution substation approximately 500 feet from the Substation.
3. Voltage at Point of Interconnection: 138 kV
4. Metered Voltage 12.5 kV
5. Loss Adjustment Due To Meter Location: Yes
6. Normal Operation of Interconnection: Closed
7. One-Line Diagram Attached: Yes
8. Description of Facilities Installed and Owned by Each Party:
 8. Company's Facilities:
 - i. the Substation and all associated facilities, including but not limited to the in-line and radial switches, Substation structures and property, and the first radial span of conductor out of the Substation
 - ii. the 12.5 kV metering facilities
 9. Golden Spread's Facilities:
 - i. the first structure outside of Substation and remaining facilities to Golden Spread's distribution substation
 - ii. isolating protective device within 2 spans of the 138 kV Point of Interconnection
 - iii. SCADA meter in series/parallel with the Company CT's/PT's
9. Operational Responsibilities of Each Party:

Each Party controls and operates the facilities it owns.
10. Maintenance Responsibilities of Each Party:

Each Party maintains the facilities it owns.

11. **Maximum Contract Demand:** 14,000 kW

12. **Other Terms and Conditions:** None

FACILITY SCHEDULE NO. 19 (continued)

Area Map

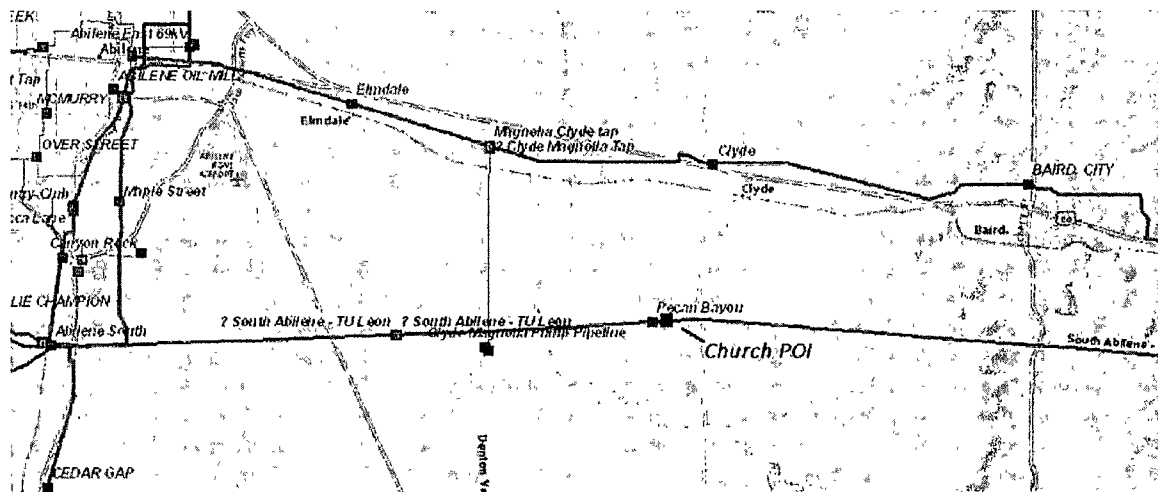

FACILITY SCHEDULE NO. 19 (continued)

Church Point of Interconnection One Line Diagram

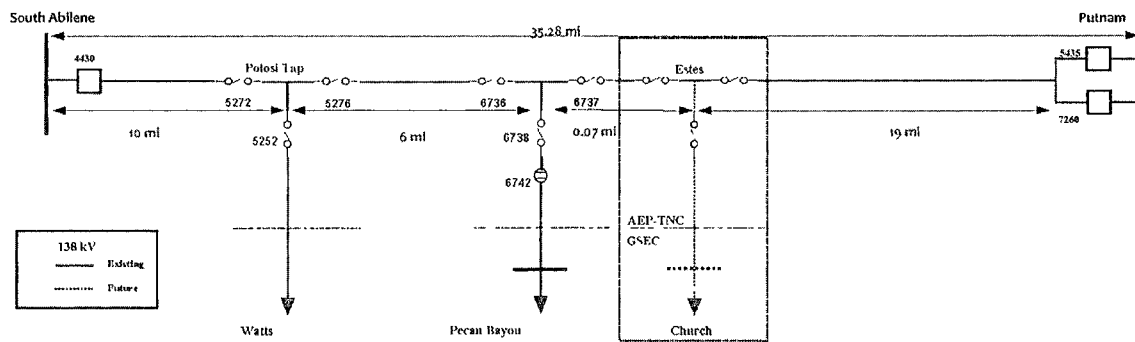

FACILITY SCHEDULE NO. 20

- 1. **Name:** Valley Creek**

- 2. **Facility Location:** AEP’s Pershing Station (“AEP Station”) (32° 10’ 11.84” N., 100° 08’ 59.21” W.) is located approximately 30.0 miles southwest of Abilene, Texas in Taylor County and 0.81 miles southwest of County Rd 260 in the Northwest Abilene to Oak Creek 138 kV transmission line right of way. The Point of Interconnection will be located on the dead-end structure at the AEP Station. More specifically, the Point of Interconnection is located where the jumper conductors from the AEP Station equipment connect to GSEC’s 138 kV transmission line conductors from the Valley Creek Substation (“Substation”).

- 3. **Delivery Voltage:** 138 kV

- 4. **Metering Voltage:** 138 kV

- 5. **Loss Adjustment Due To Meter Location:** None

- 6. **Normal Operation of Interconnection:** Closed

- 7. **One-Line Diagram Attached:** Yes

- 8. **Facilities Ownership and Installation Responsibilities of the Parties:**
 - A. **AEP will install and own the following facilities:**
 - i. the Northwest Abilene to Oak Creek 138 kV (existing) transmission line
 - ii. the AEP Station and all associated facilities, including but not limited to the in-line and radial switches
 - iii. the 138 kV meter and metering facilities for ERCOT settlement at the AEP Station
 - iv. the 138 kV jumpers at the AEP Station

 - B. **GSEC will install and own the following facilities:**
 - i. 12.47 kV and 24.9 kV meters and metering facilities at the Substation
 - ii. the 138 kV transmission line from the Substation to AEP’s Station
 - iii. SCADA meter (check) in series/parallel with the Company 138 kV CT’s/PT’s

- 9. **Facility Operation Responsibilities of the Parties:**

Each Party will operate the facilities it owns.

- 10. **Facility Maintenance Responsibilities of the Parties:**

Each Party will maintain the equipment it owns at its own expense.

- 11. **Estimated Peak Load:** 11,500 kW

12. Other Terms and Conditions:

- A. The Parties recognize that AEP is installing the facilities described in Section 8A hereinabove to facilitate GSEC's request for a new Point of Interconnection. If GSEC cancels its request for this Point of Interconnection prior to the time it is placed into service, GSEC agrees to pay the actual installed costs incurred and committed to be incurred by AEP, and the actual costs of removal of the AEP material and equipment. GSEC shall have the right to take delivery of and pay for any materials ordered but not installed provided such right shall expire if not exercised within ten (10) days after receipt of notice from the AEP; and provided further that such right shall be subject to the consent of affected vendors. If GSEC terminates and discontinues the use of this Point of Interconnection after it is energized and as a result of such termination and discontinuation of use the AEP facilities that comprise the Point of Interconnection are no longer energized or the costs of such facilities are no longer recoverable, GSEC shall pay AEP the depreciated book value plus removal cost less salvage value of such facilities, or GSEC may purchase such facilities at depreciated book value provided GSEC removes or otherwise disconnects such facilities from a direct connection to the AEP system. In the event such payment is determined to be taxable income to AEP and subject to income tax or franchise tax, GSEC shall reimburse AEP for the tax effect of such payment. AEP and GSEC shall cooperate in good faith concerning the determination of the tax effect of such payment.
- B. GSEC has requested an in-service date for the Point of Interconnection of June 1, 2019. AEP will use reasonable efforts to provide the Point of Interconnection on the desired in-service date in accordance with, and subject to the terms of, Section 3.3 of the Agreement.
- C. In the event AEP reasonably expects that it will not be able to complete the Point of Interconnection by the requested in-service date, AEP will promptly provide written notice to GSEC and will undertake reasonable efforts to meet the earliest date thereafter. At GSEC's request, AEP will also install the temporary facilities (temporary pole and hard tap conductors) necessary to energize the Point of Interconnection by the requested in-service date, and AEP will not directly assign to, or otherwise recover from, GSEC the costs it incurs in installing and removing those temporary facilities except as described in Section 12A, above. The Parties will keep each other advised periodically as to the progress of their respective design, procurement, and construction efforts regarding the Point of Interconnection. If, at any time, GSEC becomes aware that the completion of the Point of Interconnection will not be required until after the requested in-service date, GSEC will promptly provide written notice to AEP of a new, later in-service date.
- D. Parties mutually agree that this Facility Schedule may be amended to accurately document the final as-built design of the installed permanent interconnection facilities.
- E. Real Property. Unless AEP will utilize existing AEP real estate interests or unless AEP notifies GSEC in writing that it will be acquiring the real estate interests, the following terms and conditions shall be applicable if AEP is constructing a new transmission station to interconnect GSEC's facilities, or if AEP is constructing a new AEP transmission line to connect GSEC's facilities with AEP's transmission facilities:

- i) GSEC shall purchase the real estate and transfer to AEP the acreage designated for the Station development, at no cost to AEP, in fee. Once GSEC obtains title to the property, it will execute AEP's standard Option Contract, providing AEP at least two (2) months to conduct its due diligence. The due diligence period will begin after: 1) the Option Contract is fully executed; and 2) AEP has received project approval from its Board of Directors. To expedite the title search, GSEC will provide AEP with the original owner's and GSEC's vesting deeds, the title policy insuring GSEC's purchase, and any exception documents enumerated on that policy. GSEC will provide AEP with the most current survey of the property. AEP will conduct its own environmental analysis, and purchase an updated American Land Title Association (ALTA) survey with all current title exceptions and easements documented. AEP will purchase, at its option, an updated title search and policy, for fair market value, with all standard exceptions and arbitration provisions removed. GSEC will transfer the property designated for the Station site from GSEC to AEP, using AEP's standard General Warranty Deed. AEP will bear the cost of drafting the Option Contract and General Warranty Deed. The Parties agree that no changes will be made from the standard Option Contract or General Warranty Deed, except those approved in writing by AEP, as deemed appropriate by AEP.

- ii) If the Station site does not abut a public roadway, GSEC will provide AEP with legal access to the premises. Access will be either in fee, or in a perpetual easement for ingress/egress, or series of such easements, at AEP's discretion, which must include specific rights to build and maintain a roadway. The width necessary for access may vary, depending upon the terrain, but must be twenty-five (25) feet wide, at a minimum, to accommodate vehicle access for maintenance and future upgrades. If the site access is purchased in fee, the appropriate provision for that additional land will be included in AEP's standard Option Contract. If a perpetual easement is acceptable to AEP, GSEC will utilize AEP's standard Access Easement. AEP will bear the cost of drafting the Option Contract or Access Easement(s). The Parties agree that no changes will be made from the standard Access Easement, except those approved in writing by AEP, as deemed appropriate by AEP.

- iii) GSEC will grant easements and rights-of-way upon and across the lands owned by GSEC for the lines which will connect GSEC's facilities with AEP's transmission facilities, or will purchase such easements and rights-of-way across lands owned by third parties. If applicable, GSEC will be responsible for obtaining all appropriate easements and rights-of-way for connection of AEP's Station facilities with the power transmission lines in the area. GSEC shall pay the cost of acquiring all easements which are deemed necessary by AEP, including the cost of all title examinations and surveys as AEP may deem reasonably necessary. GSEC will utilize AEP's standard Easement and Right of Way Agreement for these transfers. AEP will bear the cost of drafting the Easement and Right of Way Agreement(s). The Parties agree that no changes will be made from the standard Easement and

Right of Way Agreement, except those approved in writing by AEP, as deemed appropriate by AEP.

- F. TEC will provide meter data to AEP, and if TEC determines read access by AEP to the meters is feasible, TEC will allow AEP to remotely poll the metering data from TEC's 12.5 kV metering facilities while in the temporary facilities configuration until installation of the permanent facilities.

[The remainder of this page intentionally left blank]

FACILITY SCHEDULE NO. 20 (continued)
Area Map



FACILITY SCHEDULE NO. 20 (continued)
One Line Diagram

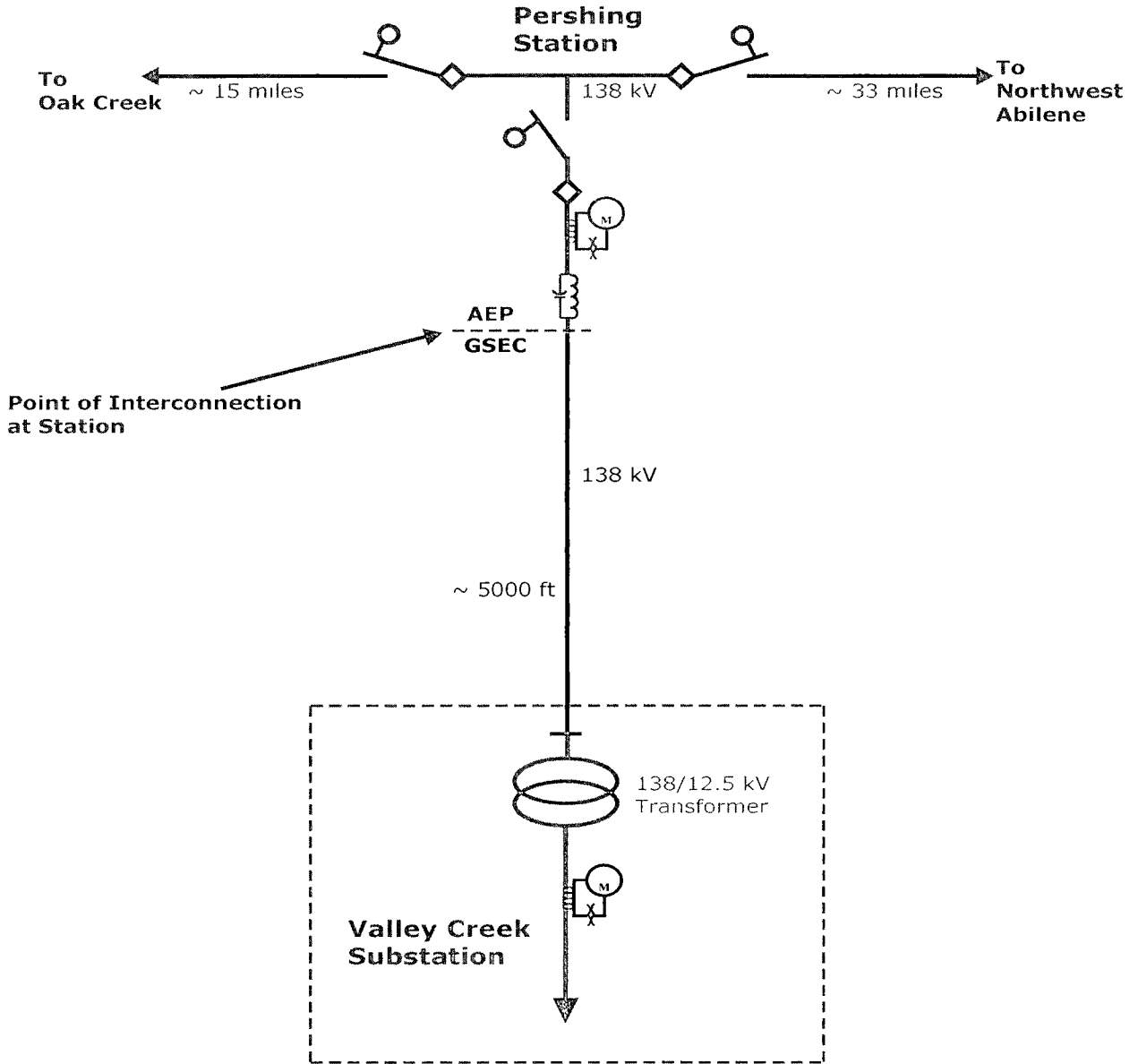

- AEP
- ==== GSEC
- GSEC Customer

Distances as shown are conceptual and not to scale

FACILITY SCHEDULE NO. 21

1. **Name:** Tomato**
2. **Facility Location:** AEP's Solanum Station ("AEP Station") (32° 21' 0.36" N., 99° 15' 49.79" W.) is located approximately 4.25 miles southwest of Putnam, Texas in Callahan County in the South Abilene to Putnam 138 kV transmission line right of way. The Point of Interconnection will be located on the dead-end structure at the AEP Station. More specifically, the Point of Interconnection is located where the jumper conductors from the AEP Station equipment connect to GSEC's 138 kV transmission line conductors from TEC's Tomato Substation ("Substation").
3. **Delivery Voltage:** 138 kV
4. **Metering Voltage:** 12.5 kV
5. **Loss Adjustment Due To Meter Location:** Yes
6. **Normal Operation of Interconnection:** Closed
7. **One-Line Diagram Attached:** Yes
8. **Facilities Ownership and Installation Responsibilities of the Parties:**
 - A. **AEP will install and own the following facilities:**
 - i. the South Abilene to Putnam 138 kV (existing) transmission line
 - ii. the AEP Station and all associated facilities, including but not limited to the in-line and radial switches
 - iii. 12.5 kV metering and metering facilities in series/parallel with the TEC's CT's/PT's
 - iv. the 138 kV jumpers at the AEP Station
 - v. wavetraps
 - B. **GSEC will install and own the following facilities:**
 - i. the 138 kV transmission line from the Substation to AEP's Station

TEC will install and own the following facilities:

 - i. the Substation and all associated facilities
 - ii. 12.5 kV meters and metering facilities in the Substation
9. **Facility Operation Responsibilities of the Parties:**

Each Party will operate the facilities it owns.
10. **Facility Maintenance Responsibilities of the Parties:**

Each Party will maintain the equipment it owns at its own expense.

11. Estimated Peak Load: 11,500 kW

12. Other Terms and Conditions:

- A. The Parties recognize that AEP is installing the facilities described in Section 8A hereinabove to facilitate GSEC's request for a new Point of Interconnection to be provided by this Agreement. If GSEC cancels its request for this Point of Interconnection GSEC agrees to pay AEP for the costs that it has incurred (including the temporary facilities costs described in Section 12(C), below) in accordance with Section 4.11 or 4.12 of the Agreement. In the event such payment is determined to be taxable income to AEP and subject to income tax or franchise tax, GSEC shall reimburse AEP for the tax effect of such payment. AEP and GSEC shall cooperate in good faith concerning the determination of the tax effect of such payment. AEP's estimated total installed cost of its facilities is Two Million Dollars (\$2,000,000).
- B. AEP's in-service date for the permanent Point of Interconnection is estimated to be twenty (20) months from the Execution Date of this Agreement. AEP will use reasonable efforts to provide the Point of Interconnection on the desired in-service date in accordance with, and subject to the terms of, Section 4.5(a) of the Agreement.
- C. In the event AEP reasonably expects that it will not be able to complete the Point of Interconnection by the requested in-service date, AEP will promptly provide written notice to GSEC and will undertake reasonable efforts to meet the earliest date thereafter. At GSEC's request, AEP will also install the temporary facilities (temporary pole and hard tap conductors) necessary to energize the Point of Interconnection by the requested in-service date, and AEP will not directly assign to, or otherwise recover from GSEC the costs it incurs in installing and removing those temporary facilities except as described in Section 12(A) above. The Parties will keep each other advised periodically as to the progress of their respective design, procurement, and construction efforts regarding the Point of Interconnection. If, at any time, GSEC becomes aware that the completion of the Point of Interconnection will not be required until after the requested in-service date, GSEC will promptly provide written notice to AEP of a new, later in-service date.
- D. Parties mutually agree that this Facility Schedule may be amended to accurately document the final as-built design of the installed permanent interconnection facilities.
- E. Real Property. Unless AEP will utilize existing AEP real estate interests or unless AEP notifies GSEC in writing that it will be acquiring the real estate interests, the following terms and conditions shall be applicable if AEP is constructing a new transmission station to interconnect GSEC's facilities, or if AEP is constructing a new AEP transmission line to connect GSEC's facilities with AEP's transmission facilities:
 - i) GSEC shall purchase the real estate and transfer to AEP the acreage designated for the Station development, at no cost to AEP, in fee. Once GSEC obtains title to the property, it will execute AEP's standard Option Contract, providing AEP at least

two (2) months to conduct its due diligence. The due diligence period will begin after: 1) the Option Contract is fully executed; and 2) AEP has received project approval from its Board of Directors. To expedite the title search, GSEC will provide AEP with the original owner's and GSEC's vesting deeds, the title policy insuring GSEC's purchase, and any exception documents enumerated on that policy. GSEC will provide AEP with the most current survey of the property. AEP will conduct its own environmental analysis, and purchase an updated American Land Title Association (ALTA) survey with all current title exceptions and easements documented. AEP will purchase, at its option, an updated title search and policy, for fair market value, with all standard exceptions and arbitration provisions removed. GSEC will transfer the property designated for the Station site from GSEC to AEP, using AEP's standard General Warranty Deed. AEP will bear the cost of drafting the Option Contract and General Warranty Deed. The Parties agree that no changes will be made from the standard Option Contract or General Warranty Deed, except those approved in writing by AEP, as deemed appropriate by AEP.

- ii) If the Station site does not abut a public roadway, GSEC will provide AEP with legal access to the premises. Access will be either in fee, or in a perpetual easement for ingress/egress, or series of such easements, at AEP's discretion, which must include specific rights to build and maintain a roadway. The width necessary for access may vary, depending upon the terrain, but must be twenty-five (25) feet wide, at a minimum, to accommodate vehicle access for maintenance and future upgrades. If the site access is purchased in fee, the appropriate provision for that additional land will be included in AEP's standard Option Contract. If a perpetual easement is acceptable to AEP, GSEC will utilize AEP's standard Access Easement. AEP will bear the cost of drafting the Option Contract or Access Easement(s). The Parties agree that no changes will be made from the standard Access Easement, except those approved in writing by AEP, as deemed appropriate by AEP.
- iii) GSEC will grant easements and rights-of-way upon and across the lands owned by GSEC for the lines which will connect GSEC's facilities with AEP's transmission facilities, or will purchase such easements and rights-of-way across lands owned by third parties. If applicable, GSEC will be responsible for obtaining all appropriate easements and rights-of-way for connection of AEP's Station facilities with the power transmission lines in the area. GSEC shall pay the cost of acquiring all easements which are deemed necessary by AEP, including the cost of all title examinations and surveys as AEP may deem reasonably necessary. GSEC will utilize AEP's standard Easement and Right of Way Agreement for these transfers. AEP will bear the cost of drafting the Easement and Right of Way Agreement(s). The Parties agree that no changes will be made from the standard Easement and Right of Way Agreement, except those approved in writing by AEP, as deemed appropriate by AEP.

- F. TEC will provide meter data to AEP, and if TEC determines read access by AEP to the meters is feasible, TEC will allow AEP to remotely poll the metering data from TEC's 12.5 kV metering facilities while in the temporary facilities configuration until installation of the permanent facilities.

[The remainder of this page intentionally left blank]

FACILITY SCHEDULE NO. 21 (continued)
Area Map

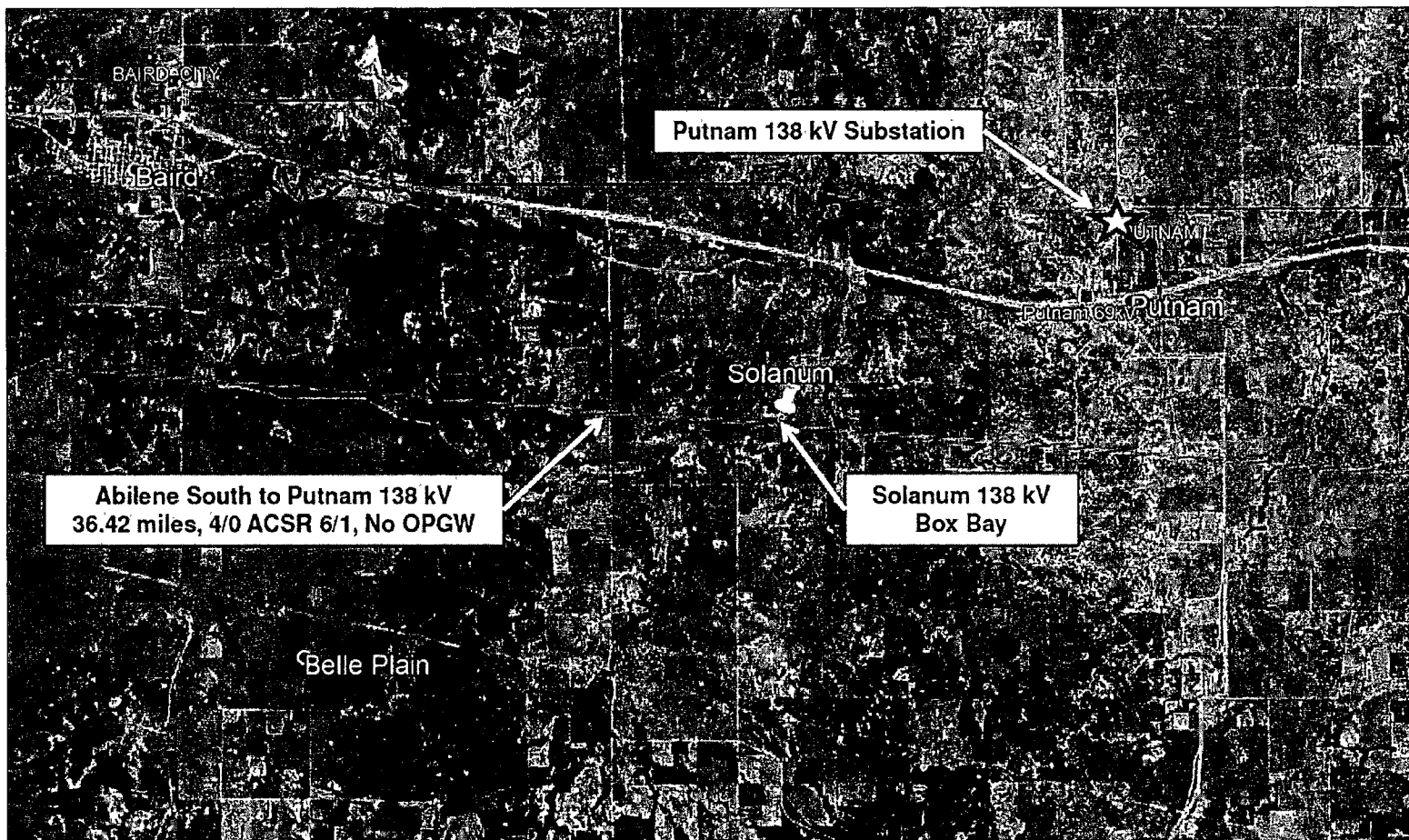

FACILITY SCHEDULE NO. 21 (continued)
One Line Diagram

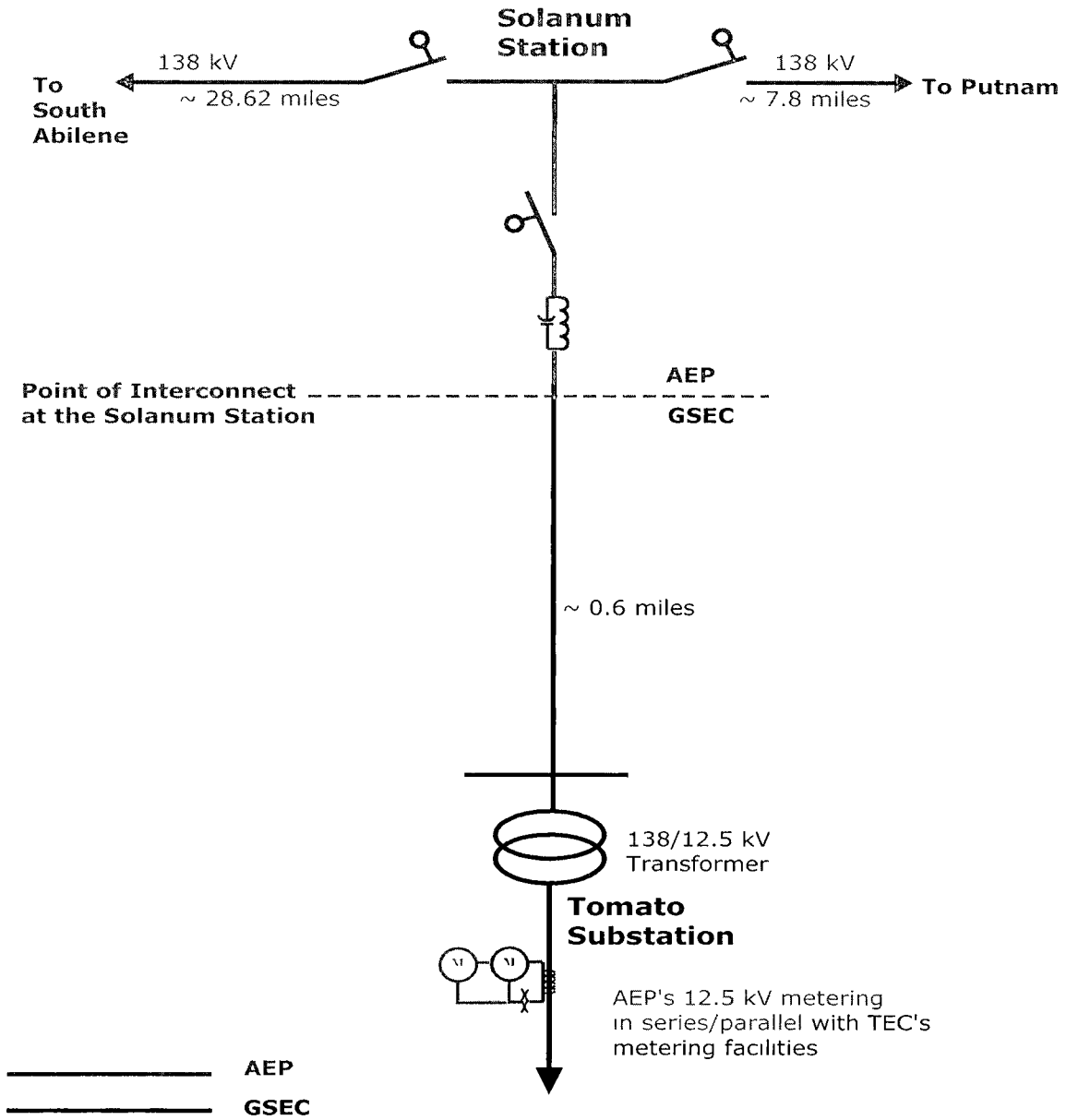

Distances as shown are conceptual and not to scale;
facilities are not shown completely.

FACILITY SCHEDULE NO. 22

1. **Name:** Atwell**

2. **Facility Location:** The Atwell Point of Interconnection (“POI”) will be located at AEP’s dead-end structure within AEP’s easement (32° 15’ 8.56” N., 99° 11’ 17.20” W.) located approximately 9.5 miles south of Putnam, Texas, east side of FM880 south and FM3265, in Callahan County in the Cross Plains to Putnam 69 kV transmission line right of way. More specifically, the Point of Interconnection is located where AEP’s jumper conductors from AEP’s dead-end structure connects to GSEC’s 69 kV transmission line conductors from TEC’s Atwell Substation (“Substation”).

3. **Delivery Voltage:** 69 kV

4. **Metering Voltage:** 12.5 kV

5. **Loss Adjustment Due To Meter Location:** Yes

6. **Normal Operation of Interconnection:** Closed

7. **One-Line Diagram Attached:** Yes

8. **Facilities Ownership and Installation Responsibilities of the Parties:**
 - A. **AEP will install and own the following facilities:**
 - i. the Cross Plains to Putnam 69 kV (existing) transmission line
 - ii. the Avenger three switch structure and all associated facilities, including but not limited to the in-line and radial switches
 - iii. the dead-end structure within AEP’s easement (POI)
 - iv. B2500 cabinet within the Substation for AEP’s 12.5 kV metering and metering facilities in series/parallel with TEC’s CT’s/PT’s at the Substation
 - v. the jumpers at the Avenger three switch structure
 - vi. B2500 cabinet with remote terminal unit, Supervisory Control and Data Acquisition, and batteries at the Avenger three switch structure
 - vii. fiber from AEP’s dead-end structure within AEP’s easement to the Substation steel structure
 - viii. fiber from the Substation steel structure to AEP’s B2500 within the Substation

 - B. **GSEC will install and own the following facilities:**
 - i. the 69 kV transmission line from the Substation to AEP’s dead-end structure

 - C. **TEC will install and own the following facilities:**
 - i. the Substation and all associated facilities
 - ii. 12.5 kV meters and metering facilities within the Substation
 - iii. four (4) inch conduit (for AEP’s fiber) from the Substation steel structure to AEP’s B2500 within the Substation

9. Facility Operation Responsibilities of the Parties:

Each Party will operate the facilities it owns.

10. Facility Maintenance Responsibilities of the Parties:

Each Party will maintain the equipment it owns at its own expense.

11. Estimated Peak Load: 2,000 kW

12. Other Terms and Conditions:

- A. The Parties recognize that AEP is installing the facilities described in Section 8A hereinabove to facilitate GSEC's request for a new Point of Interconnection to be provided by this Agreement. If GSEC cancels its request for this Point of Interconnection GSEC agrees to pay AEP for the costs that it has incurred (including the temporary facilities costs described in Section 12(C), below) in accordance with Section 4.11 or 4.12 of the Agreement. In the event such payment is determined to be taxable income to AEP and subject to income tax or franchise tax, GSEC shall reimburse AEP for the tax effect of such payment. AEP and GSEC shall cooperate in good faith concerning the determination of the tax effect of such payment. AEP's estimated total installed cost of its facilities is Two Million Seven Hundred Sixty Thousand Dollars (\$2,760,000)
- B. AEP's in-service date for the permanent Point of Interconnection is estimated to be eight (8) months from the Execution Date of this Agreement. AEP will use reasonable efforts to provide the Point of Interconnection on the desired in-service date in accordance with, and subject to the terms of, Section 4.5(a) of the Agreement.
- C. In the event AEP reasonably expects that it will not be able to complete the Point of Interconnection by the requested in-service date, AEP will promptly provide written notice to GSEC and will undertake reasonable efforts to meet the earliest date thereafter. At GSEC's request, AEP will also install the temporary facilities (temporary pole and hard tap conductors) necessary to energize the Point of Interconnection by the requested in-service date, and AEP will not directly assign to, or otherwise recover from, GSEC the costs it incurs in installing and removing those temporary facilities except as described in Section 12(A), above. The Parties will keep each other advised periodically as to the progress of their respective design, procurement, and construction efforts regarding the Point of Interconnection. If, at any time, GSEC becomes aware that the completion of the Point of Interconnection will not be required until after the requested in-service date, GSEC will promptly provide written notice to AEP of a new, later in-service date.
- D. Parties mutually agree that this Facility Schedule may be amended to accurately document the final as-built design of the installed permanent interconnection facilities.
- E. Real Property. Unless AEP will utilize existing AEP real estate interests or unless AEP notifies GSEC in writing that it will be acquiring the real estate interests, the following

terms and conditions shall be applicable if AEP is constructing a new transmission station to interconnect GSEC's facilities, or if AEP is constructing a new AEP transmission line to connect GSEC's facilities with AEP's transmission facilities:

- i) GSEC shall purchase the real estate and transfer to AEP the acreage designated for the Station development, at no cost to AEP, in fee. Once GSEC obtains title to the property, it will execute AEP's standard Option Contract, providing AEP at least two (2) months to conduct its due diligence. The due diligence period will begin after: 1) the Option Contract is fully executed; and 2) AEP has received project approval from its Board of Directors. To expedite the title search, GSEC will provide AEP with the original owner's and GSEC's vesting deeds, the title policy insuring GSEC's purchase, and any exception documents enumerated on that policy. GSEC will provide AEP with the most current survey of the property. AEP will conduct its own environmental analysis, and purchase an updated American Land Title Association (ALTA) survey with all current title exceptions and easements documented. AEP will purchase, at its option, an updated title search and policy, for fair market value, with all standard exceptions and arbitration provisions removed. GSEC will transfer the property designated for the Station site from GSEC to AEP, using AEP's standard General Warranty Deed. AEP will bear the cost of drafting the Option Contract and General Warranty Deed. The Parties agree that no changes will be made from the standard Option Contract or General Warranty Deed, except those approved in writing by AEP, as deemed appropriate by AEP.
- ii) If the Station site does not abut a public roadway, GSEC will provide AEP with legal access to the premises. Access will be either in fee, or in a perpetual easement for ingress/egress, or series of such easements, at AEP's discretion, which must include specific rights to build and maintain a roadway. The width necessary for access may vary, depending upon the terrain, but must be twenty-five (25) feet wide, at a minimum, to accommodate vehicle access for maintenance and future upgrades. If the site access is purchased in fee, the appropriate provision for that additional land will be included in AEP's standard Option Contract. If a perpetual easement is acceptable to AEP, GSEC will utilize AEP's standard Access Easement. AEP will bear the cost of drafting the Option Contract or Access Easement(s). The Parties agree that no changes will be made from the standard Access Easement, except those approved in writing by AEP, as deemed appropriate by AEP.
- iii) GSEC will grant easements and rights-of-way upon and across the lands owned by GSEC for the lines which will connect GSEC's facilities with AEP's transmission facilities, or will purchase such easements and rights-of-way across lands owned by third parties. If applicable, GSEC will be responsible for obtaining all appropriate easements and rights-of-way for connection of AEP's Station facilities with the power transmission lines in the area. GSEC shall pay the cost of acquiring all easements which are deemed necessary by AEP, including the cost of all title examinations and surveys as AEP may deem reasonably necessary. GSEC will utilize AEP's standard Easement and Right of Way Agreement for these transfers. AEP will bear the cost of drafting the Easement and Right of Way Agreement(s). The Parties agree that no

changes will be made from the standard Easement and Right of Way Agreement, except those approved in writing by AEP, as deemed appropriate by AEP.

- iv) TEC will provide meter data to AEP, and if TEC determines read access by AEP to the meters is feasible, TEC will allow AEP to remotely poll the metering data from TEC's 12.5 kV metering facilities while in the temporary facilities configuration until installation of the permanent facilities.

[The remainder of this page intentionally left blank]

FACILITY SCHEDULE NO. 22 (continued)
Area Map

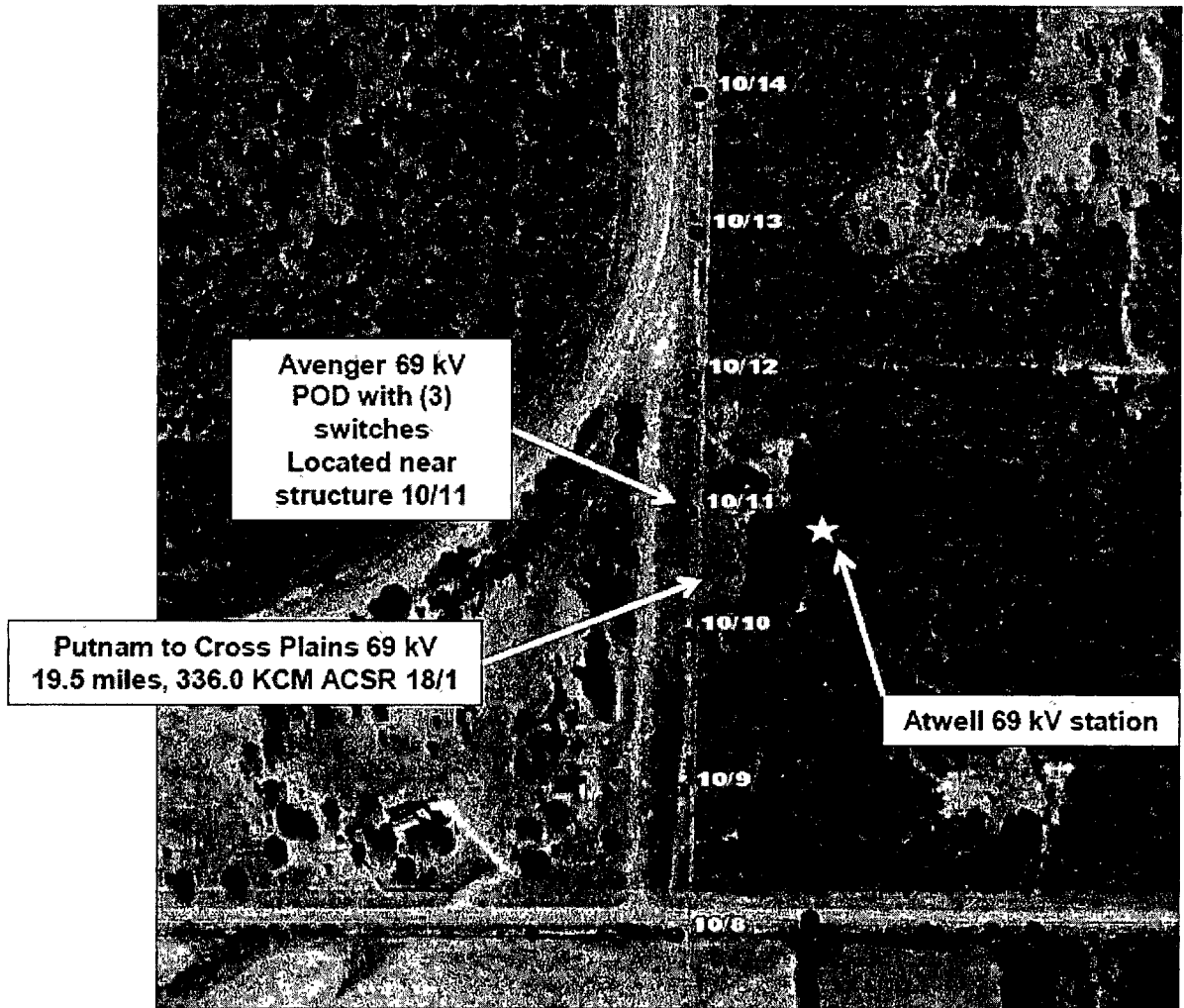

FACILITY SCHEDULE NO. 22 (continued)
 One Line Diagram

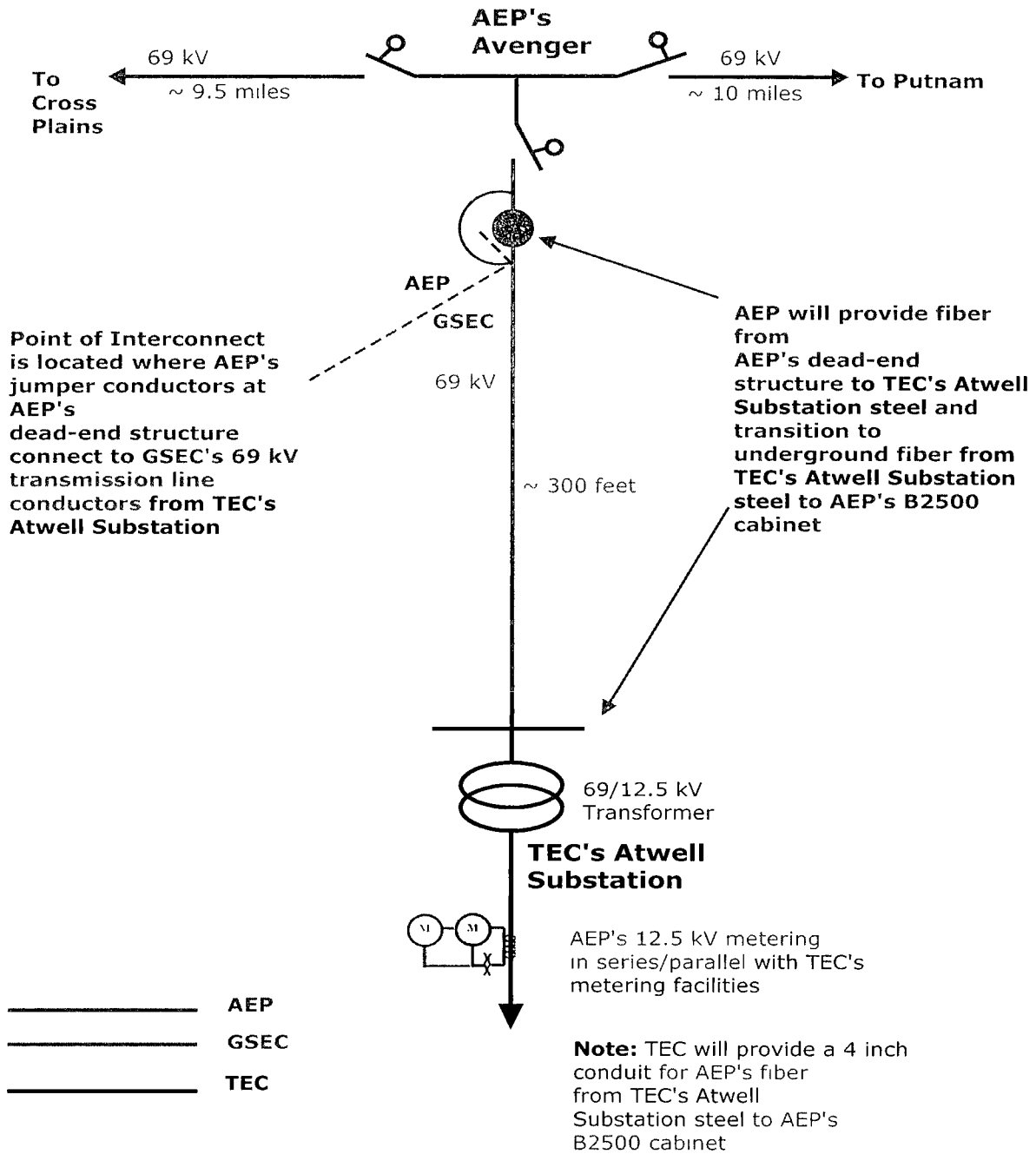

Distances as shown are conceptual and not to scale;
 facilities are not shown completely.