

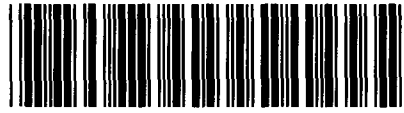

Control Number: 35077



Item Number: 1068

Addendum StartPage: 0

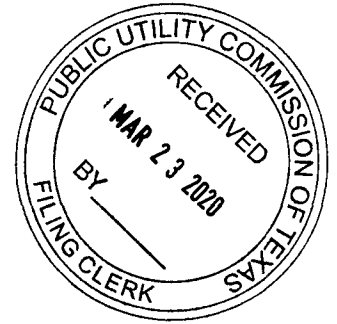

**FIFTH AMENDED AND RESTATED
INTERCONNECTION AGREEMENT**

AMONG

AEP TEXAS INC.,

SOUTHWEST TEXAS ELECTRIC COOPERATIVE, INC.,

AND

GOLDEN SPREAD ELECTRIC COOPERATIVE, INC.

DATED 3/17/2020 | 1:22 PM EDT

**FIFTH AMENDED AND RESTATED
INTERCONNECTION AGREEMENT
AMONG
AEP TEXAS INC.,
SOUTHWEST TEXAS ELECTRIC COOPERATIVE, INC.,
AND
GOLDEN SPREAD ELECTRIC COOPERATIVE, INC.**

THIS FIFTH AMENDED AND RESTATED INTERCONNECTION AGREEMENT (“Agreement”), entered into as of 3/17/2020 | 1:22 PM EDT (“Execution Date”) by and among **AEP Texas Inc.**, (as successor by merger to AEP Texas North Company) a Texas corporation (“Company” or “AEP”), **Southwest Texas Electric Cooperative, Inc.**, a Texas cooperative corporation (“Southwest Texas” or “SWTEC”) and **Golden Spread Electric Cooperative, Inc.**, a Texas cooperative corporation (“Golden Spread” or “GSEC”). References to the “Parties” in the Agreement shall mean Company, Southwest Texas, and Golden Spread, collectively. References to a “Party” in the Agreement shall mean each individual Company, Southwest Texas, and Golden Spread. References to “Cooperative” in the Agreement shall mean Southwest Texas or Golden Spread, as appropriate, depending on the Cooperative designated in Exhibit A and applicable Facility Schedule attached to the Agreement as the Cooperative that installs, owns, operates, and maintains the Point of Interconnection facilities.

WITNESSETH

WHEREAS, the Parties each own and operate electric systems in the State of Texas for the transmission and distribution of electric energy and power; and

WHEREAS, the Parties are members of the Electric Reliability Council of Texas (“ERCOT”) and are subject to regulation by the Public Utility Commission of Texas (“PUCT”); and

WHEREAS, the Parties have established or shortly will establish new Points of Interconnection between their electrical systems; and

WHEREAS, the Parties entered into a Fourth Amended and Restated Interconnection Agreement dated March 1, 2016 (the “Fourth Amended and Restated Agreement”), in accordance with the AEP Open Access Transmission Service Tariff (“AEP OATT”) which required the Cooperative taking service under the AEP OATT to implement an interconnection agreement with the Company; and

WHEREAS, the Parties desire to amend and restate the Fourth Amended and Restated Agreement to terminate Facility Schedule No. 28 that provides for the Flat Rock Point of Interconnection per GSEC and SWTEC request dated November 4, 2019; and

WHEREAS, the Parties desire to amend and restate the Fourth Amended and Restated Agreement by adding new Facility Schedule No. 33 that provides for the Wolfcamp Point of Interconnection located on the N. McCamey to Santa Rita via Crossover 138 kV transmission line.

SWTEC will own Martin substation that connects to the AEP Wolfcamp Point of Interconnection, and will incorporate the Flat Rock existing load of 3MW and add new additional estimated load of 7MW; and

WHEREAS, the Parties desire to amend and restate the Original Agreement to reflect these changes and to make certain other changes; and

WHEREAS, the Parties desire to interconnect their respective transmission and/or distribution systems in the respects, and under the terms and conditions, set forth below; and.

NOW, THEREFORE, in consideration of the premises and of the mutual covenants and conditions herein set forth, the Parties agree as follows:

ARTICLE I - EFFECTIVE DATE AND TERM

1.1 This Agreement and any subsequent addendum to this Agreement shall become effective on the date accepted by the Federal Energy Regulatory Commission (“**FERC**”), or any other regulatory agency or agencies having jurisdiction. The Parties shall request the FERC or any other regulatory agency or agencies having jurisdiction to make the effective date be the date first appearing above. This Agreement shall remain in effect for a period of two (2) years from the effective date, and shall continue in effect thereafter for periods of two (2) years each unless canceled after such initial period or any subsequent period either by mutual agreement or by either Party upon at least twenty-four (24) months written notice to the other Party. Upon termination of this Agreement, each Party shall discontinue the use of the facilities of the other and shall disconnect the Points of Interconnection.

1.2 Notwithstanding the foregoing Section 1.1, if Company serves such notice of termination and Cooperative reasonably determines that the continued interconnection of its facilities to the facilities of the Company is needed to provide continuous and adequate service to its customers, then both Parties shall enter into good faith negotiations concerning the terms of a replacement interconnection agreement. If the Parties cannot agree to the terms of such a replacement agreement that would become effective on or prior to the termination date of this Agreement, Company shall file an unexecuted replacement agreement with the FERC and Cooperative shall be entitled to challenge any provisions of such replacement agreement that are considered unjust or unreasonable, or unduly discriminatory. If Company assigns this Agreement pursuant to Article XII to an entity that is not subject to FERC jurisdiction a condition of such assignment shall be that the non-FERC jurisdictional entity shall file this Agreement or a proposed replacement agreement with the applicable state regulatory authority.

ARTICLE II – OBJECTIVE AND SCOPE

2.1 It is the intent of the Parties, by this Agreement, to state the terms and conditions under which the Parties’ transmission and/or distribution systems will be interconnected and to identify the facilities and equipment provided by each Party at the Points of Interconnection.

2.2 This Agreement shall apply to the ownership, construction, operation, and maintenance of those facilities that are specifically identified and described in the Facility Schedules that are attached hereto and incorporated herein.

2.3 This Agreement, including all attached Facility Schedules, constitutes the entire agreement and understanding between the Parties with regard to the interconnection of the facilities of the Parties at the Points of Interconnection expressly provided for in this Agreement. The Parties are not bound by or liable for any statement, representation, promise, inducement, understanding, or undertaking of any kind or nature (whether written or oral) with regard to the subject matter hereof if not set forth or provided for herein. This Agreement replaces and supersedes all other agreements and undertakings, oral and written, between the Parties with regard to the subject matter hereof. It is expressly acknowledged that the Parties may have other agreements covering other services not expressly provided for herein; such agreements are unaffected by this Agreement.

ARTICLE III - DEFINITIONS

For purposes of this Agreement, the following definitions shall apply:

3.1 Agreement means this Fifth Amended and Restated Interconnection Agreement, as amended and restated herein, together with all exhibits, schedules and attachments applying hereto, including any exhibits, schedules, attachments, and any amendments hereafter made.

3.2 ERCOT means the Electric Reliability Council of Texas, Inc., or its successor in function.

3.3 ERCOT Requirements shall mean the ERCOT Nodal Operating Guides and ERCOT Nodal Protocols, adopted by ERCOT, and approved by the PUCT, including any attachments or exhibits referenced in the ERCOT Nodal Protocols, as amended from time to time, that contain the scheduling, operating, planning, reliability, and settlement (including customer registration) policies, rules, guidelines, procedures, standards, and criteria of ERCOT.

3.4 Facility Schedule(s) shall mean the addendum(s) to this Agreement that describe the agreement on ownership, control, operation, and maintenance responsibilities of the Parties at the Point(s) of Interconnection.

3.5 Good Utility Practice shall mean any of the practices, methods and acts engaged in or approved by a significant portion of the electric utility industry during the relevant time period, or any of the practices, methods and acts which, in the exercise of reasonable judgment in light of the facts known at the time the decision was made, could have been expected to accomplish the desired result at a reasonable cost consistent with good business practices, reliability, safety, and expedition. Good Utility Practice is not intended to be limited to the optimum practice, method, or act to the exclusion of all others, but rather to be acceptable practices, methods, or acts generally accepted in the region. Good Utility Practice may include, but is not limited to, conformance with the applicable and consistently applied reliability criteria, standards and operating guides of ERCOT and the NERC, or successor organization(s).

3.6 NERC shall mean the North American Electric Reliability Corporation or its successor in function.

3.7 NERC Reliability Standards shall mean the mandatory electric reliability standards approved by the FERC and enforced by NERC.

3.8 Point(s) of Interconnection shall mean the points of interconnection identified in Exhibit A and the Facilities Schedules which are attached hereto and incorporated herein and future points of interconnection that may be established under this Agreement at which the electrical systems of the Parties are connected or may, by the closure of normally open switches, be connected.

3.9 PUCT shall mean the Public Utility Commission of Texas or its successor in function.

ARTICLE IV - ESTABLISHMENT AND TERMINATION OF POINTS OF INTERCONNECTION

4.1 The Parties agree to comply with NERC Reliability Standards as they relate to the interconnection of their facilities at the locations identified and described in the Facility Schedules which are attached hereto and incorporated herein.

4.2 The Parties agree to interconnect their facilities at the locations, and in accordance with the terms and conditions, specified in the attached Facility Schedule(s). All Points of Interconnection shall be specified in Exhibit A and the Facility Schedule(s) attached hereto and made a part hereof. The Facility Schedule(s) shall specify the responsibilities of the Parties with respect to ownership, control, operation, and maintenance of the interconnection facilities.

4.3 [Reserved]

4.4 Unless otherwise provided in a Facility Schedule, each Party shall, at each Point of Interconnection, at its own risk and expense, design, install, or cause the design and installation of the transmission or distribution facilities (including all apparatus and necessary protective devices) on its side of the Point of Interconnection, so as to reasonably minimize the likelihood of voltage and frequency abnormalities, originating in the system of one Party, from affecting or impairing the system of the other Party, or other systems to which the system of such Party is interconnected. The Parties agree that all Points of Interconnection will be established and maintained in conformance with the ERCOT Requirements. The Parties agree to cause their systems to be constructed in accordance with specifications at least equal to those provided by the National Electrical Safety Code, approved by the American National Standards Institute, in effect at the time of construction. Except as otherwise provided in the Facility Schedules, each Party will be responsible for the equipment and facilities it owns on its side of the Point of Interconnection.

4.5 From time to time, a Point of Interconnection may be added, changed, modified, or deleted from this Agreement as mutually agreed by the Parties (not to be unreasonably withheld) and/or as ordered by a regulatory authority having jurisdiction thereof. Any such change, addition, or deletion

shall be recorded in Exhibit A and a Facility Schedule in such a way that the numbering of the other Facility Schedules is not changed.

a) If a new Point of Interconnection is desired, the other Party shall be notified in writing of 1) the need for a new Point of Delivery; 2) the desired location of the new Point of Interconnection; 3) the designation of the new Point of Interconnection; 4) a description of the maximum demand desired; and 5) the date desired for commencement of service. Written notification of a request for a new Point of Interconnection shall be given to the other Party at least twelve (12) months prior to the date on which commencement of service at such Point of Interconnection is desired; however, the other Party may, at its sole option, waive all or part of the twelve (12) month written notification requirement. The other Party will use reasonable efforts to provide an additional Point of Interconnection on the date desired; however, the Parties recognize that completion of the Point of Interconnection by the desired in-service date is contingent upon the other Party's ability to acquire the necessary permits, regulatory approvals, property rights, rights-of-way, material and equipment sufficiently in advance of the desired date for the construction and installation of facilities necessary to provide such service. Each Party will, upon request, promptly provide the other Party with information concerning its operations and facilities needed to facilitate the design and construct the Point of Interconnection.

b) Subject to regulatory approval, if required, either Party may terminate a Point of Interconnection on twelve (12) months advance written notice. Upon termination of a Point of Interconnection, each Party shall discontinue the use of the facilities of the other associated with the use of that Point of Interconnection and shall disconnect from that Point of Interconnection. The Parties agree to use reasonable efforts to coordinate the termination of a Point of Interconnection to minimize any disruption in service by either Party. Notwithstanding the foregoing, if Company serves such notice of termination and Cooperative reasonably determines that the continued interconnection of its facilities to the facilities of the Company is needed to provide continuous and adequate service to its customers, the procedures set forth in Section 1.2 of this Agreement shall apply.

4.6 Subject to regulatory approval, if required, unless mutually agreed, no Party shall have the right to disconnect from the other Party at any Point of Interconnection specified on Exhibit A and a Facility Schedule, originally attached to this Agreement or added subsequent to the execution of this Agreement, except as set forth in Section 4.5 above, or for reason of a material violation of the terms of this Agreement, for which opportunity to correct such violation was given under Section 15.1 of this Agreement and such violation was not corrected in accordance with said Section 15.1.

4.7 For facilities not specified in the Facility Schedules, or if a Party makes equipment changes or additions to the equipment at a Point of Interconnection, which may affect the operation or performance of the other Party's interconnection facilities, each Party agrees to notify the other Party, in writing, of such changes. Such changes shall be made in accordance with Good Utility Practice, ERCOT Requirements, the National Electrical Safety Code, and other applicable codes, and standards in effect at the time of construction, and shall be coordinated between the Parties.

4.8 Each Party agrees to provide current as-built drawings to the other Party of the facilities owned by that Party at each Point of Interconnection.

4.9 The Parties agree to coordinate and cooperate on assessments of the reliability impacts to the interconnected transmission system for new facilities requesting connection to their distribution or transmission facilities, in accordance with the NERC Reliability Standards.

4.10 Except as otherwise provided in a Facilities Schedule, each Party will pay for its own interconnection facilities and recover such costs pursuant to such Party's transmission and/or distribution service tariff(s).

4.11 If Cooperative requests a new Point of Interconnection and later cancels its request for this Point of Interconnection prior to the time the Point of Interconnection is placed in service, Cooperative agrees to pay the actual installed costs incurred and committed to be incurred by the Company, and the actual costs of removal of the Company's material and equipment. The total installed cost of the Company's facilities will be provided in the Facilities Schedule. Cooperative shall have the right to take delivery of and pay for any materials ordered but not installed provided such right shall expire if not exercised within ten (10) days after receipt of notice from the Company; and provided further that such right shall be subject to the consent of affected vendors.

4.12 If Cooperative terminates and discontinues the use of an energized Point of Interconnection in accordance with Section 4.5 hereinabove, and as a result of such termination and discontinuation of use the Company facilities that comprise the Point of Interconnection are no longer energized or the costs of such facilities are no longer recoverable, Cooperative shall pay Company the depreciated book value plus removal cost less salvage value of such facilities, or Cooperative may purchase such facilities at depreciated book value provided Cooperative removes or otherwise disconnects such facilities from a direct connection to the Company system.

4.13 If an energized Point of Interconnection is terminated in response to a default by Cooperative in accordance with Article 15 hereinbelow, and as a result of such termination, the cost of facilities that comprise the Point of Interconnection are no longer energized or the costs of such facilities are no longer recoverable, Cooperative shall pay Company the depreciated book value plus removal cost less salvage value of such facilities, or Cooperative may purchase such facilities at depreciated book value provided Cooperative removes or otherwise disconnects such facilities from a direct connection to the Company system.

ARTICLE V - OTHER SERVICES

5.1 This Agreement is applicable only to the interconnection of the facilities of the Parties at the Points of Interconnection and does not obligate either Party to provide, or entitle either Party to receive, any service not expressly provided for herein. Each Party is responsible for making the arrangements necessary to receive any other service that either Party may desire from the other Party or any third party.

5.2 All transmission, transformation, distribution, metering, operations, and maintenance, engineering, billing or other miscellaneous services will be provided and charged under agreements separate from this Agreement.

ARTICLE VI - SYSTEM OPERATION AND MAINTENANCE

6.1 Unless otherwise provided by the Facility Schedules, each Party shall, at each Point of Interconnection, at its own risk and expense, operate and maintain the facilities (including all apparatus and necessary protective devices) it owns or hereafter may own, so as to reasonably minimize the likelihood of voltage and frequency abnormalities, originating in the system of one Party, from affecting or impairing the system of the other Party, or other systems to which the Party is interconnected. The Parties agree that all Points of Interconnection will be operated and maintained in conformance with the ERCOT Requirements.

6.2 Unless otherwise provided by the Facility Schedules, each Party will be responsible for the operation, maintenance and inspection of all facilities it owns now or hereafter may own associated with each Point of Interconnection.

6.3 Unless otherwise provided by the Facility Schedules, each Party shall operate the facilities within its transmission network. The operation of the electrical network shall be such that power flows that enter and exit one Party's transmission facilities do not have undue impacts on another Party's transmission facilities. Operational responsibility for facilities owned by a Party, but installed in the other Party's substation or transmission line, will be identified in the Facility Schedule for that particular Point of Interconnection.

6.4 During the term of this Agreement, the Parties will, consistent with maintaining good operating practices, coordinate their operations to maintain continuity of services to their respective customers to the extent practicable. Planned facility maintenance by either Party that will cause a deviation from the normal power and energy flow at a Point of Interconnection will be scheduled at a mutually agreeable time. Except as otherwise permitted by the terms of this Agreement, no changes will be made in the normal operation of a Point of Interconnection without the mutual agreement of the Parties. The Parties will, to the extent necessary to support continuity of operations, coordinate the operation of protective devices on the facilities they operate in the proximity of the Points of Interconnection that might reasonably be expected to affect the operation of facilities on the other Party's system.

6.5 Each Party will provide the reactive requirements for its own system in accordance with the ERCOT Requirements. Each Party will provide the reactive requirements for its own system so as not to impose a burden on the other Party's system.

6.6 During periods of emergency conditions declared by ERCOT, or as necessary to restore customer service, either Party may operate equipment that is normally operated by the other Party, provided the authorization to do so must first be received from the Party that normally operates the equipment, such authorization not to be unreasonably withheld or delayed. It shall be considered reasonable for the Party that normally operates such equipment to deny such a request by the other Party if the withholding Party will provide such operation within the time frame called for in the circumstances. Such operations by the other Party will be at no cost to the owner or normal operator of the equipment.

6.7 Each Party will determine the operating limits of the facilities that it owns and make such limits known to the Party operating those facilities. The Party operating those facilities will not exceed those limits without prior approval of the Party owning the facilities.

ARTICLE VII - RIGHT OF ACCESS, EQUIPMENT INSTALLATION AND REMOVAL

7.1 Each Party shall permit duly authorized representatives and employees of the other Party to enter upon its premises for the purpose of inspecting, testing, repairing, renewing, or exchanging any or all of the equipment owned by such other Party that is located on such premises or for the purpose of performing any work necessary in the performance of this Agreement.

7.2 Each Party grants to the other Party permission to install, maintain, and/or operate, or cause to be installed, maintained, and/or operated, on its premises, the necessary equipment, apparatus, and devices required for the performance of this Agreement. Any such installation, maintenance, and operation to be performed, except in the case of emergencies, shall be performed only after a schedule of such activity has been submitted and agreed upon by the Parties.

7.3 Any and all equipment, apparatus, and devices placed or installed, or caused to be placed or installed by one Party on, or in, the premises of the other Party, shall be and remain the property of the Party owning and installing such equipment, apparatus, devices, or facilities, regardless of the mode and manner of annexation or attachment to real property. Upon the termination of any Point of Interconnection under this Agreement, the Party owning and installing such equipment, apparatus, devices, or facilities on the property of the other Party, shall 1) have the right to sell such equipment, apparatus, devices, or facilities to the other Party if the other Party wishes to purchase such equipment, apparatus, devices, or facilities or 2) to enter the premises of the other Party and, within a reasonable time, remove such equipment, apparatus, devices, or facilities, at no cost to the owner of the premises. If, upon the termination of any Point of Interconnection under this Agreement, equipment of a Party that is installed on the premises of the other Party is neither sold to the other Party nor removed by the owning Party within a reasonable time, it shall be considered abandoned by the owning Party and may be disposed of by the other Party in the manner it shall determine appropriate; provided, however, that any net cost incurred by the disposing Party shall be reimbursed by the abandoning Party.

7.4 Each Party shall clearly mark its respective equipment, apparatus, devices, or facilities with appropriate ownership identification.

7.5 Either Party may request the other Party to upgrade or modify its terminal facilities at a Point of Interconnection in accordance with the requesting Party's standard design of equipment, provided that the upgrade or modification is consistent with good utility practice and, if applicable, is approved by ERCOT. The requesting Party shall provide the responsive Party a minimum of twenty-four (24) months notice of the upgrade or modification of its terminal facilities at a Point of Interconnection, absent mutual acceptance of a shorter notice period. The Parties agree to use reasonable efforts to coordinate the upgrade or modification of terminal facilities at a Point of Interconnection to minimize any disruption in service.

ARTICLE VIII - METERING AND RECORDS

8.1 All metering equipment required herein shall be selected, installed, tested, operated, and maintained by the Party owning such metering equipment in accordance with Good Utility Practice and the ERCOT Requirements.

8.2 The non-owning Party of the metering equipment shall be permitted to witness any testing, inspection, maintenance, or alteration of such metering equipment owned by the other Party. The owner of such equipment shall give reasonable advance notice of all tests and inspections so that representatives of the other Party may be present. After proper notification to the other Party, the owner may proceed with the scheduled tests or inspections regardless of whether a witness is present.

8.3 If any test or inspection of metering equipment shows that it does not meet the accuracy requirements established by the ERCOT Requirements, the meter or other equipment found to be inaccurate or defective shall be promptly repaired, adjusted, or replaced by the owner. Should metering equipment fail to register, the power and energy delivered and received shall be determined in accordance with the ERCOT Requirements.

8.4 As long as metering, telemetering or communications facilities are required by the ERCOT Requirements and are operated and maintained in accordance with ERCOT guidelines and Protocols, the Party owning these facilities shall allow the other Party to read the meter by means of the existing telemetering and communications facilities. The other Party shall be responsible for any incremental costs incurred by the owning Party to provide any meter reading capability over and above that which is required by the owning Party.

ARTICLE IX – COMMUNICATION AND TELEMETERING FACILITIES

9.1 Each Party shall provide, at its own expense, the necessary communication and telemetering facilities needed for the control and operation of its transmission and/or distribution system.

9.2 All communication and telemetering facilities required herein shall be selected, installed, tested, operated, and maintained by the Party owning such equipment in accordance with Good Utility Practice and the ERCOT Requirements.

ARTICLE X - INDEMNIFICATION

EACH PARTY SHALL ASSUME ALL LIABILITY FOR, AND SHALL INDEMNIFY, DEFEND, AND SAVE HARMLESS THE OTHER PARTY, ITS DIRECTORS, OFFICERS, AND AGENTS (INCLUDING, BUT NOT LIMITED TO, DIRECTORS, OFFICERS, AND EMPLOYEES OF ITS AFFILIATES AND CONTRACTORS) FROM ANY AND ALL DAMAGES, LOSSES, CLAIMS, INCLUDING CLAIMS AND ACTIONS RELATING TO INJURY TO OR DEATH OF ANY PERSON (INCLUDING THE EMPLOYEES OF THE INDEMNIFIED PARTY) OR DAMAGE TO PROPERTY (INCLUDING PROPERTY OF THE INDEMNIFIED PARTY) DEMANDS, SUITS, RECOVERIES, COSTS AND EXPENSES,

COURT COSTS, ATTORNEY FEES, AND ALL OTHER OBLIGATIONS BY OR TO THIRD PARTIES, ARISING OUT OF OR RESULTING FROM NEGLIGENCE OR OTHER FAULT IN THE DESIGN, CONSTRUCTION, OR OPERATION OF THEIR RESPECTIVE FACILITIES, DURING THE PERFORMANCE OF THIS AGREEMENT AND TO THE EXTENT PERMITTED BY LAW, EXCEPT IN CASES OF NEGLIGENCE OR INTENTIONAL WRONGDOING BY THE INDEMNIFIED PARTY.

ARTICLE XI - NOTICES

11.1 Notices of an administrative nature, including but not limited to a notice of termination, notice of default, request for amendment, change to a Point of Interconnection, or request for a new Point of Interconnection, shall be forwarded to the designees listed below for each Party and shall be deemed properly given if delivered in writing to the following:

If to Company:

American Electric Power Service Corporation
Director, System Interconnections
Robert Pennybaker
212 East Sixth Street
Tulsa, OK 74119
918-599-2723
rlpennybaker@aep.com

With copy to:

American Electric Power Service Corporation
Manager, Transmission Customer Engagement
212 East Sixth Street
Tulsa, OK 74119
918-599-2653
naward@aep.com

If to Southwest Texas:

General Manager
Southwest Texas Electric Cooperative, Inc.
William (Buff) Whitten
P.O. Box 677
Eldorado, TX 76936-0677
101 East Gillis
Eldorado, TX 76936
325-853-2544
800-643-3980
wwhitten@swtec.com

If to Golden Spread:

Golden Spread Electric Cooperative, Inc.
Scott Gross
President & Chief Executive Offer
P.O. Box 9898
Amarillo, TX 79105-5898
806-379-7766

11.2 The above listed names, titles, and addresses of either Party may be changed by written notification to the other signatories.

ARTICLE XII - SUCCESSORS AND ASSIGNS

12.1 Subject to the provisions of Section 12.2 below, this Agreement shall be binding upon and inure to the benefit of the permitted successors and assigns of the respective Parties.

12.2 No Party shall assign its interest in this Agreement in whole or in part without the prior written consent of the other Party. Such consent shall not be unreasonably withheld, provided that no Party will be required to consent to any assignment which would, in its sole judgment and among other reasons, subject it to additional federal or state regulation, result in the imposition of additional costs of administration which the Party requesting consent to assignment does not agree to reimburse, or in any way diminish the reliability of its system, enlarge its obligations or otherwise create or maintain an unacceptable condition. The respective obligations of the Parties under this Agreement may not be changed, modified, amended, or enlarged, in whole or in part, by reason of the sale, merger, or other business combination of either Party with any other person or entity. Notwithstanding the foregoing, a Party may assign, without the consent of the other Party, its interest in this Agreement, in whole or in part, to a successor to all or a substantial portion of the Party's transmission and distribution business; to any affiliate of the assigning Party with an equal or greater credit rating; to any transmission service provider with the legal authority and operational ability to satisfy the obligations of the assigning Party under this Agreement; or for collateral security purposes in connection with any financing or financial arrangements. In the event that a Party transfers its interest in this Agreement, in whole or in part, to an affiliate of the assigning Party and such affiliate assignee is not subject to FERC jurisdiction, such affiliate assignee shall negotiate with the other Party any changes needed to protect the rights of the non-assigning Party pursuant to this Agreement and to conform to applicable state regulations and, if agreement is not achieved, file the agreement on an unexecuted basis with the applicable state regulatory authority for approval.

12.3 The several provisions of this Agreement are not intended to and shall not create rights of any character whatsoever in favor of any persons, corporations, or associations other than the Parties to this Agreement, and the obligations herein assumed are solely for the use and benefit of the Parties to this Agreement.

ARTICLE XIII - GOVERNING LAW AND REGULATION

13.1 This Agreement must in all respects be governed by, interpreted, construed, and enforced in accordance with the laws of the State of Texas except as to matters exclusively controlled by the Constitution and statutes of the United States of America. This Agreement is subject to all valid applicable federal, state, and local laws, ordinances, rules and regulations of duly constituted regulatory authorities having jurisdiction.

13.2 This Agreement and all obligations hereunder, are expressly conditioned upon obtaining approval or authorization or acceptance for filing by any regulatory authority whose approval, authorization, or acceptance for filing is required by law. After execution by the Parties, the Company will file this Agreement with the FERC with copies of such filing provided to the PUCT. The Parties hereby agree to support the approval of this Agreement before such regulatory authorities and to provide such documents, information, and opinions as may be reasonably required or requested by either Party in the course of approval proceedings.

13.3 In the event that a regulatory authority having jurisdiction over this Agreement orders a change in the terms of this Agreement, the Parties agree to negotiate in good faith a replacement term that will most nearly accomplish the purpose and intent of the original term consistent with the regulatory order. If the Parties cannot reach an agreement over the new term, and if the old term is an essential provision of this Agreement, either Party may elect to terminate this Agreement by providing sixty (60) days prior written notice of such election to the other Party. An election to terminate under this provision shall not affect either Party's duty to perform prior to the effective date of termination. Notwithstanding the foregoing, if Company serves such notice of termination and Cooperative notifies Company that the continued interconnection to Company facilities is needed to assure the reliable supply of electric service to retail load, the procedures set forth in Section 1.2 of this Agreement shall apply.

13.4 In the event any part of this Agreement is declared invalid by a court of competent jurisdiction, the remainder of this Agreement shall remain in full force and effect and shall constitute a binding agreement between the Parties provided, however, that if either Party determines, in its sole discretion, that there is a material change in this Agreement by reason of any provision or application being finally determined to be invalid, illegal, or unenforceable, the Parties shall negotiate in good faith to establish such substitute provisions as will eliminate such material adverse effect to the extent practicable.

ARTICLE XIV – DEFAULT AND FORCE MAJEURE

Neither Party shall be considered in default with respect to any obligation hereunder, other than the payment of money, if prevented from fulfilling such obligations by reason of any cause beyond its reasonable control, including, but not limited to, outages or interruptions due to weather, accidents, equipment failures or threat of failure, strikes, civil unrest, injunctions or order of governmental or regulatory authority having jurisdiction ("Force Majeure"). If performance by either Party has been prevented by such event, the affected Party shall promptly notify the other Party of the existence, nature and expected duration of the event, and shall promptly and diligently attempt to remove the cause of its failure to perform, except that neither Party shall be obligated to agree to any quick settlement of any

strike or labor disturbance, that, in the affected Party's opinion, may be inadvisable or detrimental, or to appeal from any administrative or judicial ruling.

ARTICLE XV - TERMINATION ON DEFAULT

15.1 The term “Default” shall mean the failure of either Party to perform any material obligation in the time or manner provided in this Agreement. No Default shall exist where such failure to discharge an obligation (other than the payment of money) is the result of Force Majeure as defined in this Agreement or the result of an act or omission of the other Party. Upon a Default, the non-defaulting Party shall give written notice of such Default to the defaulting Party. Except as provided in Section 15.2, the defaulting Party shall have thirty (30) days from receipt of the Default notice within which to cure such Default; provided however, if such Default is not capable of cure within thirty (30) days, the defaulting Party shall commence such cure within thirty (30) days after notice and continuously and diligently complete such cure within ninety (90) days from receipt of the Default notice; and, if cured within such time, the Default specified in such notice shall cease to exist.

15.2 If a Default is not cured as provided in this Article, or if a Default is not capable of being cured within the period provided for herein, the non-defaulting Party shall have the right to terminate this Agreement by written notice at any time until cure occurs, and be relieved of any further obligation hereunder and, whether or not that Party terminates this Agreement, to recover from the defaulting Party all amounts due hereunder, plus all other damages and remedies to which it is entitled at law or in equity. The provisions of this Section will survive termination of this Agreement.

15.3 The failure of a Party to this Agreement to insist, on any occasion, upon strict performance of this Agreement will not be considered to waive the obligations, rights, or duties imposed upon the Parties by this Agreement.

ARTICLE XVI – MISCELLANEOUS PROVISIONS

16.1 Any undertaking by a Party to the other Party under this Agreement shall not constitute the dedication of the electrical system or any portion thereof of that Party to the public or to the other Party, and it is understood and agreed that any such undertaking shall cease upon the termination of this Agreement.

16.2 IN NO EVENT SHALL EITHER PARTY BE LIABLE UNDER ANY PROVISION OF THIS AGREEMENT FOR ANY LOSSES, DAMAGES, COSTS OR EXPENSES FOR ANY SPECIAL, INDIRECT, INCIDENTAL, CONSEQUENTIAL, OR PUNITIVE DAMAGES, INCLUDING BUT NOT LIMITED TO LOSS OF PROFIT OR REVENUE, LOSS OF THE USE OF EQUIPMENT, COST OF CAPITAL, COST OF TEMPORARY EQUIPMENT OR SERVICES, WHETHER BASED IN WHOLE OR IN PART IN CONTRACT, IN TORT, INCLUDING NEGLIGENCE, STRICT LIABILITY, OR ANY OTHER THEORY OF LIABILITY; PROVIDED, HOWEVER, THAT DAMAGES FOR WHICH A PARTY MAY BE LIABLE TO THE OTHER PARTY UNDER ANOTHER AGREEMENT WILL NOT BE

CONSIDERED TO BE SPECIAL, INDIRECT, INCIDENTAL, OR CONSEQUENTIAL DAMAGES HEREUNDER.

16.3 This Agreement shall not affect the obligations or rights of either Party with respect to other agreements. Each Party to this Agreement represents that there is no agreement or other obligation binding upon it, which, as such Party is presently aware, would limit the effectiveness or frustrate the purpose of this Agreement.

16.4 This Agreement may be amended only upon mutual agreement of the Parties, which amendment will not be effective until reduced in writing and executed by the Parties.

16.5 The descriptive headings of the various sections of this Agreement have been inserted for convenience of reference only and are to be afforded no significance in the interpretation or construction of this Agreement.

16.6 This Agreement will be executed in two or more counterparts, each of which is deemed an original, but all constitute one and the same instrument.

16.7 This Agreement constitutes the entire agreement of the Parties relating to the subject matter hereof, and supersedes all prior agreements, including the Original Agreement, the First Restatement, the Second Restatement, and all amendments thereto.

[Signatures are on next page]

IN WITNESS WHEREOF, the Parties have caused this Agreement to be executed by the undersigned authorized representatives.

AEP TEXAS INC.

SOUTHWEST TEXAS ELECTRIC COOPERATIVE, INC.

DS
alt

By: DocuSigned by:
Robert W Bradish
CE4ED3037D3440A

By: William W. Whitten

Name: Robert W. Bradish
Title: Vice President

Name: William Whitten
Title: General Manager

Date: 3/17/2020 | 1:22 PM EDT

Date: 3/17/2020

GOLDEN SPREAD ELECTRIC COOPERATIVE, INC.

By: Scott Gross

Name: Scott Gross
Title: President and Chief Executive Officer (Interim)

Date: 3/16/2020

EXHIBIT "A"

Facility Schedule No.	Name of Point of Interconnection (# of Points) ** denotes GSEC POI	Delivery Voltage [kV]	LDF Charge Type ⁽¹⁾	Meter Voltage [kV]	Meter Installed Cost [ψ denotes Cooperative owns]	Estimated Peak Load [kW]
1	Allen (1)	12.5				
2	Arrott (1)	12.5				
3	Barnhart (1)	12.5				
4	Big Lake (1)	12.5				
5	Cauthorn (1)	138				
6	Eldorado (1)	12.5				
7	Girvin (1)	12.5				
8	Hulldale (1)	69				
9	Menard(1)	12.5				
10	Mertzon (1)	12.5				
11	Middle Valley (1)	69				
12 (terminated)	Middle Valley 24.9 (0)	-				
13	Midway Lane (2)	12.5				
14	North Sonora (1)	12.5				
15 (terminated)	Ozona (0)	-				
16	Powell Field (1)	12.5				
17	Sheffield (1)	12.5				
18	Sonora (1)	12.5				
19	Sonora Atlantic (1)	12.5				
20	Strauss Ranch (1)	69				
21	Tippett/McCamey (1)	12.5				

EXHIBIT "A" (continued)

Facility Schedule No.	Name of Point of Interconnection (# of Points) ** denotes GSEC POI	Delivery Voltage [kV]	LDF Charge Type ⁽¹⁾	Meter Voltage [kV]	Meter Installed Cost [ψ denotes Cooperative owns]	Estimated Peak Load [kW]
22	Walker Field/Mesa View (1)	12.5				
23 (terminated)	White-Baker (0)	-				
24	Pecos River (1)	69				
25 (terminated)	Barnhart Phillips (0)	-				
26	Northern Natural Line (1)	12.5				
27	Yucca (1)	12.5				
28 (terminated)	Flat Rock (0)	12.5				
29	Rock Hollow (1)	138				
30	Pandale (1)	12.5				
31	Trinity Field (1)	12.5				
32	Pave Paws (1)	69				
33	Martin (1)	138		12.5		10,000

FACILITY SCHEDULE NO. 1

1. **Name:** Allen
2. **Facility Location:** The Point of Interconnection (“POI”) is located at the meter pole on Company’s distribution feeder located approximately 2.5 mile northeast of Iraan, Texas, in Pecos County. More specifically, the POI is where Company’s jumpers physically connect to Cooperative’s distribution conductors terminated on the meter pole.
3. **Delivery Voltage:** 12.5 kV
4. **Metered Voltage:** 12.5 kV
5. **Loss Adjustment Due To Meter Location:** None
6. **Normal Operation of Interconnection:** Closed
7. **One-Line Diagram Attached:** Yes
8. **Facilities Ownership Responsibilities of the Parties:**
 - A. **Company owns the following facilities:**
 - i. the feeder facilities on the source side of this POI
 - ii. the meter pole and associated metering equipment
 - B. **Cooperative owns the following facilities:**
 - i. the switch and remaining feeder facilities on the load side of this POI
9. **Operational Responsibilities of Each Party:**

Each Party will operate the facilities it owns.
10. **Maintenance Responsibilities of Each Party:**

Each Party will maintain the facilities it owns at its expense.
11. **Estimated Peak Load:** 1,000 kW
12. **Other Terms and Conditions:** None

[The remainder of this page intentionally left blank]

FACILITY SCHEDULE NO. 1 (continued)
One-Line Diagram

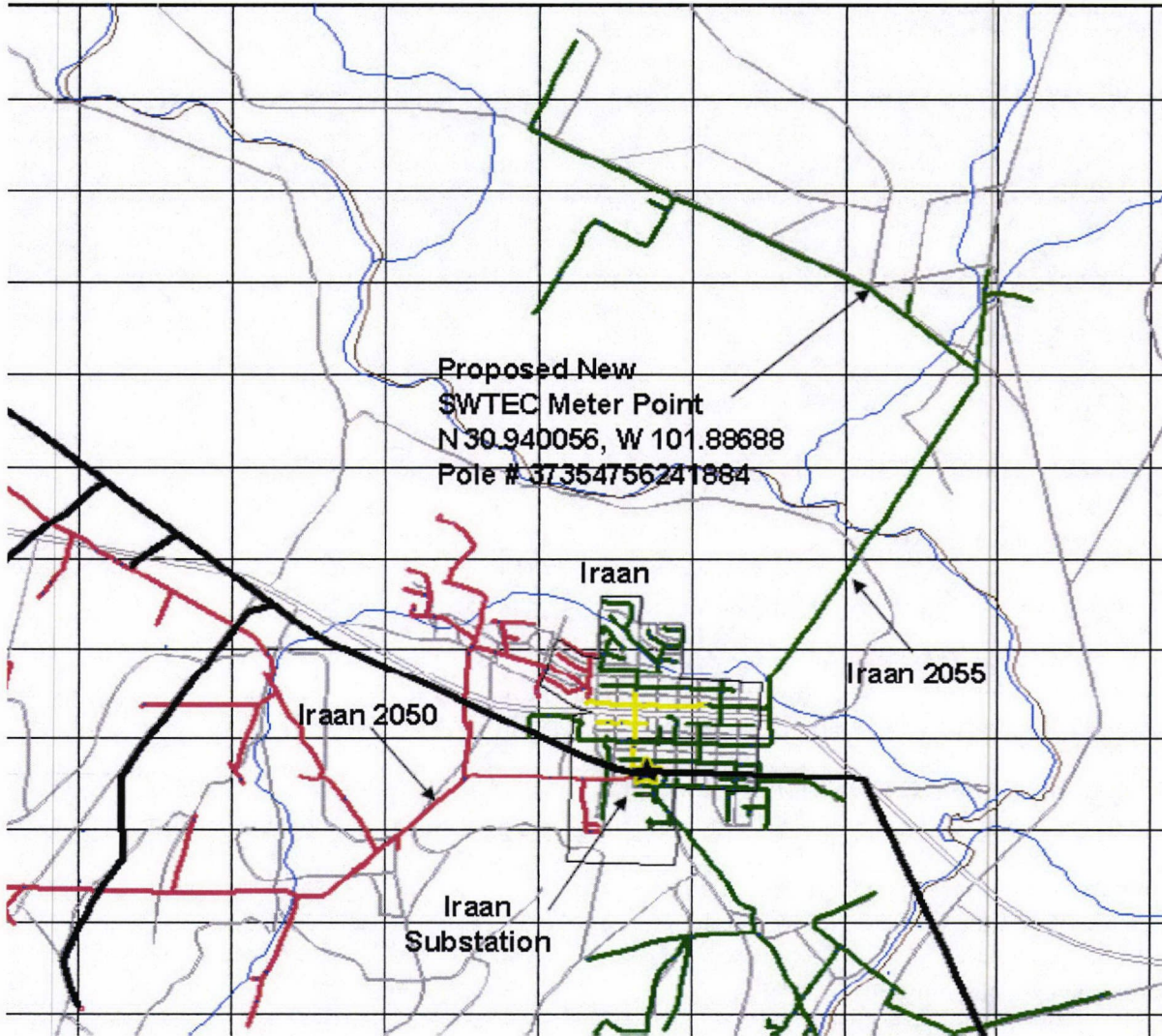

FACILITY SCHEDULE NO. 2

1. **Name:** Arrott
2. **Facility Location:** The Point of Interconnection (“POI”) is in Company’s Arrott Substation (“Substation”) eight (8) miles south of Christoval, Texas, in Schleicher County, and two-hundred (200) yards east of and adjacent to Highway 277. More specifically, the POI is where the Company’s jumper conductors from the Substation equipment physically connect to Cooperative’s distribution feeder conductors.
3. **Delivery Voltage:** 12.5 kV
4. **Metered Voltage:** 12.5 kV
5. **Loss Adjustment Due to Meter Location:** No
6. **Normal Operation of Interconnection:** Closed
7. **One-Line Diagram Attached:** Yes
8. **Facilities Ownership Responsibilities of the Parties:**
 - A. **Company owns the following facilities:**
 - i.the Substation and all the facilities within it
 - B. **Cooperative owns the following facilities:**
 - i.the 12.5 kV distribution feeder
9. **Operation Responsibilities of Each Party:**

Each Party will operate the facilities it owns.
10. **Maintenance Responsibilities of Each Party:**

Each Party will maintain the facilities it owns at its expense.
11. **Estimated Peak Load:** 1,050 kW
12. **Other Terms and Conditions:**
 - i. Cooperative is to have access to Company’s OCR (5335)
 - ii. Cooperative is to have access to the Company’s load side disconnect switch (5336).

[The remainder of this page intentionally left blank]

FACILITY SCHEDULE NO. 2 (continued) One-Line Diagram

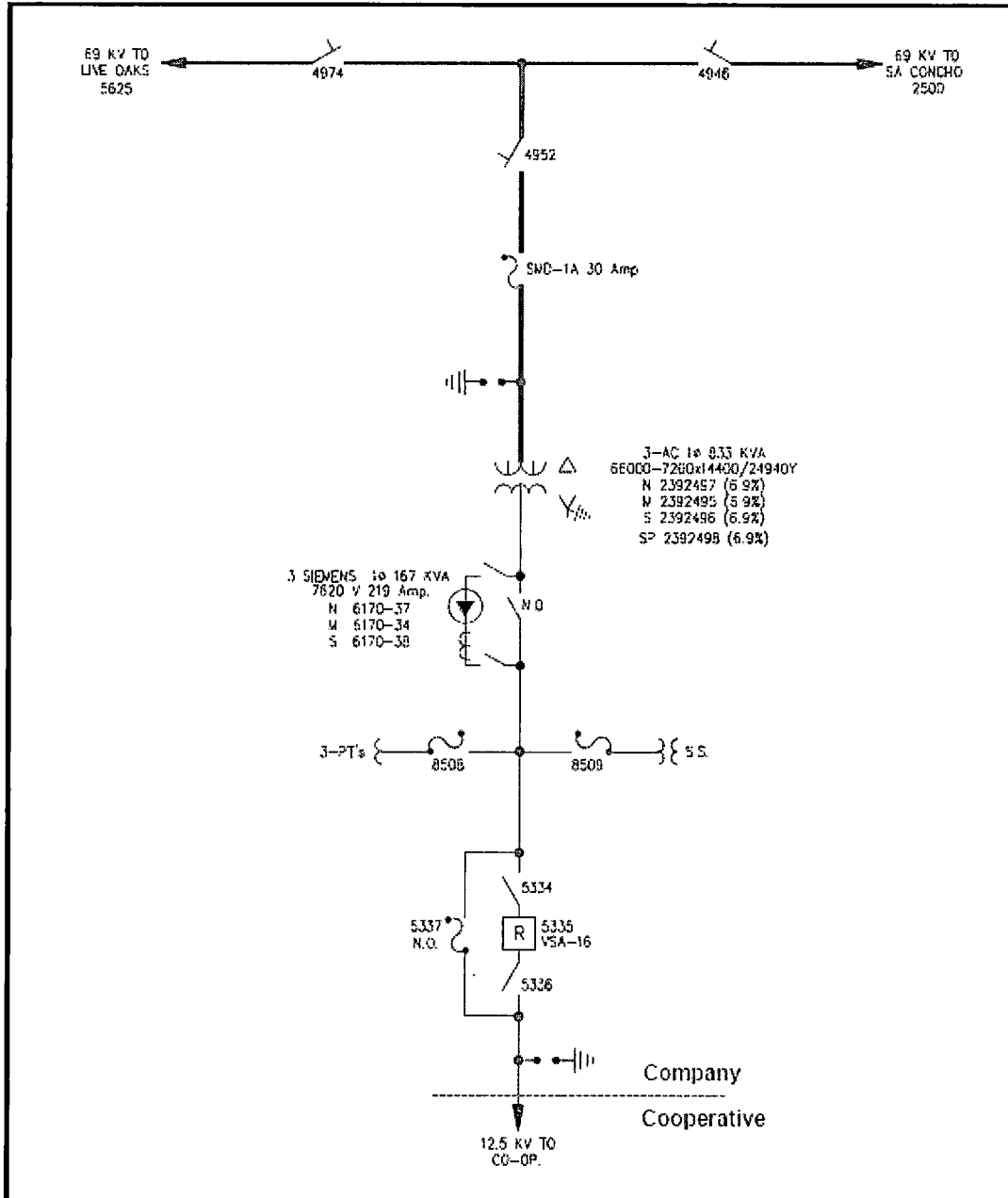

TEXAS NORTH COMPANY		ARROTT-ELDORADO #196		69/12.5KV	
APP'D BY :	DR. BY : CRT	CH. BY :	DATE : 12/10/09	DISPATCH ONE LINE	
AMERICAN ELECTRIC POWER 1 RIVERSIDE PLAZA COLUMBUS, OH 43215		Work Order #: 19299003		DWG. No. W196SO01	REV 5

FACILITY SCHEDULE NO. 3

1. **Name:** Barnhart
2. **Facility Location:** The Point of Interconnection (“POI”) is located northwest of Barnhart, Texas, in Irion County, approximately 2130 circuit feet from the Barnhart substation located west of and adjacent to State Highway 163 (Main Street) and north of Storey Street. More specifically, the POI is where the Company’s jumper conductors physically connect to Cooperative’s distribution conductors terminating on the meter pole.
3. **Delivery Voltage:** 12.5 kV
4. **Metered Voltage:** 12.5 kV
5. **Loss Adjustment Due To Meter Location:** None
6. **Normal Operation of Interconnection:** Closed
7. **One-Line Diagram Attached:** Yes
8. **Facilities Ownership Responsibilities of the Parties:**
 - A. **Company owns the following facilities:**
 - i. approximately 2130 feet of 4/0 ACSR of 12.5 kV distribution feeder serving the POI
 - ii. the Barnhart substation and all the facilities within it
 - iii. the meter pole
 - iv. the metering facilities
 - B. **Cooperative owns the following facilities:**
 - i. the facilities on the load-side of the meter
 - ii. overcurrent devices at the POI
 - iii. SCADA meter in series/parallel with the Company CTs/PTs
9. **Operation Responsibilities of Each Party:**

Each Party will operate the facilities it owns.
10. **Maintenance Responsibilities of Each Party:**

Each Party will maintain the equipment it owns at its expense.
11. **Estimated Peak Load:** 6100 kW
12. **Other Terms and Conditions:**
 - A. Cooperative is to have access to OCR (R72401 and R724002) in accordance with Article VII of the Agreement.

- B. Cooperative and Company will mutually agree on the coordination of the overcurrent devices provided by Cooperative at the POI.

[The remainder of this page intentionally left blank]

FACILITY SCHEDULE NO. 3 (continued)

Conceptual One-line Drawing of Point of Interconnect

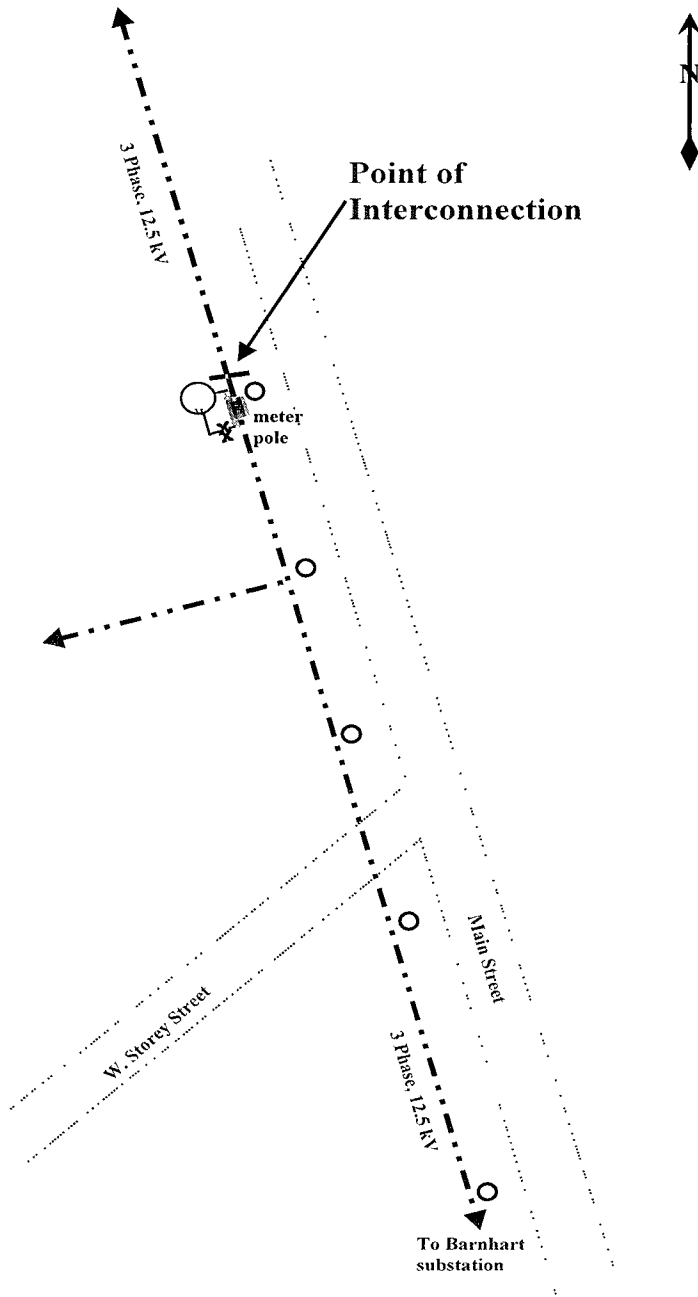

Company 
SWTEC

Conceptual Drawing
Not to scale

FACILITY SCHEDULE NO. 4

1. **Name:** **Big Lake**

2. **Facility Location:** The Point of Interconnection (“POI”) is at the Company’s Big Lake Substation (“Substation”) approximately two (2) miles east of Big Lake, Texas, in Reagan County, south of and adjacent to US 67. More specifically, the POI is where the Company’s jumper conductors from the Substation equipment physically connect to Cooperative’s distribution feeder conductors.

3. **Delivery Voltage:** 12.5 kV

4. **Metered Voltage:** 12.5 kV

5. **Loss Adjustment Due To Meter Location:** No

6. **Normal Operation of Interconnection:** Closed

7. **One-Line Diagram Attached:** Yes

8. **Facilities Ownership Responsibilities of the Parties:**
 - A. **Company owns the following facilities:**
 - i. the Substation and all the facilities within it

 - B. **Cooperative owns the following facilities:**
 - i. the 12.5 kV distribution feeder

9. **Operation Responsibilities of Each Party:**

Each Party will operates the facilities it owns.

10. **Maintenance Responsibilities of Each Party:**

Each Party will maintains the facilities it owns at its own expense.

11. **Estimated Peak Load:** 1,890 kW

12. **Other Terms and Conditions:**
 - i. Cooperative is to have access to OCB (5340)
 - ii. Cooperative is to have access to the load side disconnect switch (5341)

[The remainder of this page intentionally left blank]

FACILITY SCHEDULE NO. 4 (continued) One-Line Diagram

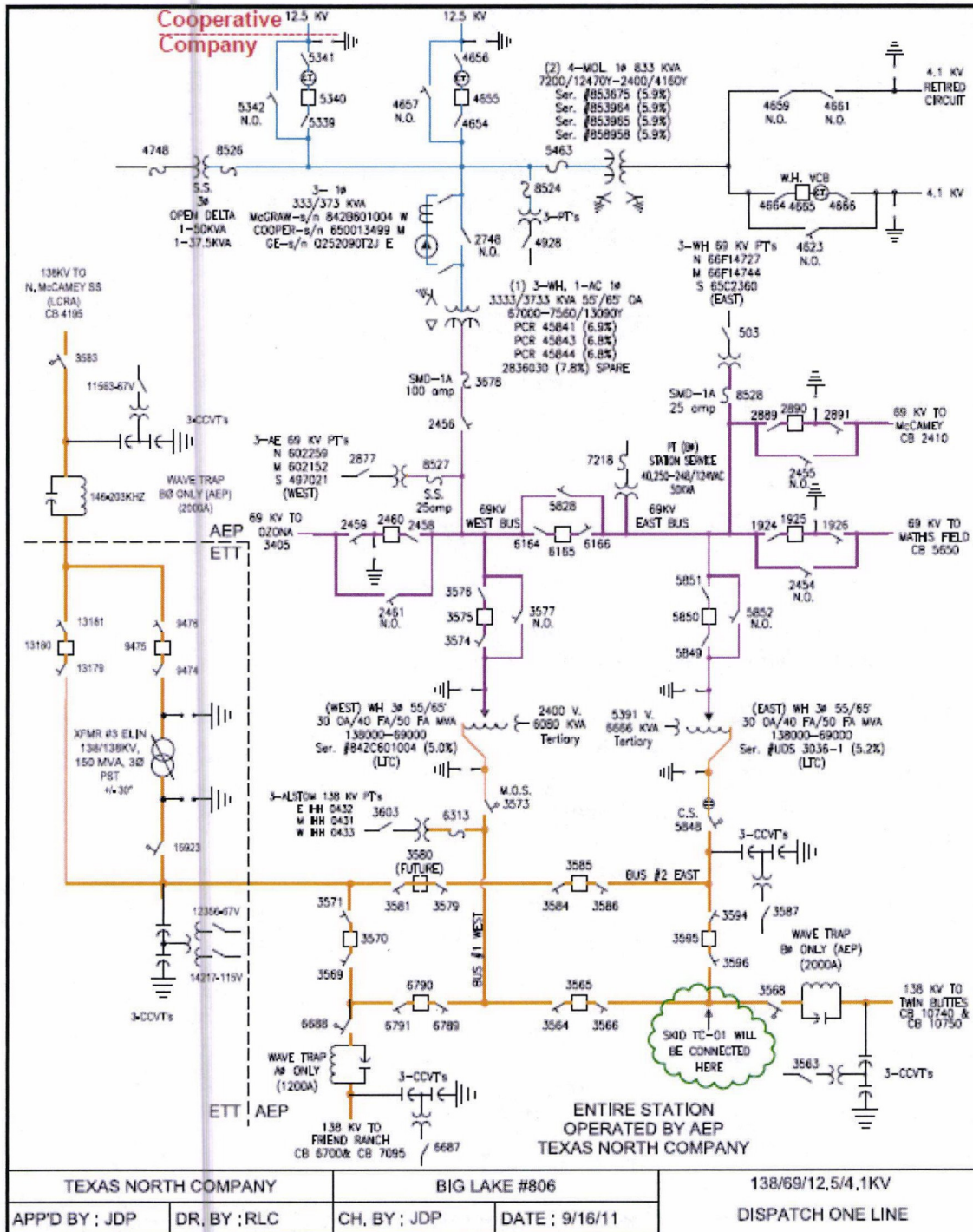

FACILITY SCHEDULE NO. 5

1. **Name:** Cauthorn
2. **Facility Location:** The Point of Interconnection (“POI”) is in Cooperative’s Cauthorn Substation (“Substation”). Survey 22, GC & SF RR Company Survey of Sutton County approximately 5900 feet north of the Sutton and Edwards county line. Approximately two and a quarter (2.25) miles northwest of where US Highway 277 and State Road 55 intersect. More specifically, the POI is where the Company’s jumper conductors from the Sonora to Hamilton Rd 138 kV transmission line physically connect to Cooperative’s Substation equipment.
3. **Delivery Voltage:** 138 kV
4. **Metered Voltage:** 24.9 kV
5. **Loss Adjustment Due To Meter Location:** No
6. **Normal Operation of Interconnection:** Closed
7. **One-Line Diagram Attached:** Yes
8. **Facilities Ownership Responsibilities of the Parties:**
 - A. **Company owns the following facilities:**
 - i. the Sonora to Hamilton Rd 138 kV transmission line
 - B. **Cooperative owns the following facilities:**
 - i. the Substation and all the facilities within it
9. **Operation Responsibilities of Each Party:**

Each Party will operate the facilities it owns.
10. **Maintenance Responsibilities of Each Party:**

Each Party will maintain the facilities it owns at its own expense.
11. **Estimated Peak Load:** 900 kW
12. **Other Terms and Conditions:**
 - i. Company is to have access to Substation switch (5428)
 - ii. PT & CT sold to Cooperative

[The remainder of this page intentionally left blank]

FACILITY SCHEDULE NO. 5 (continued)
One-Line Diagram

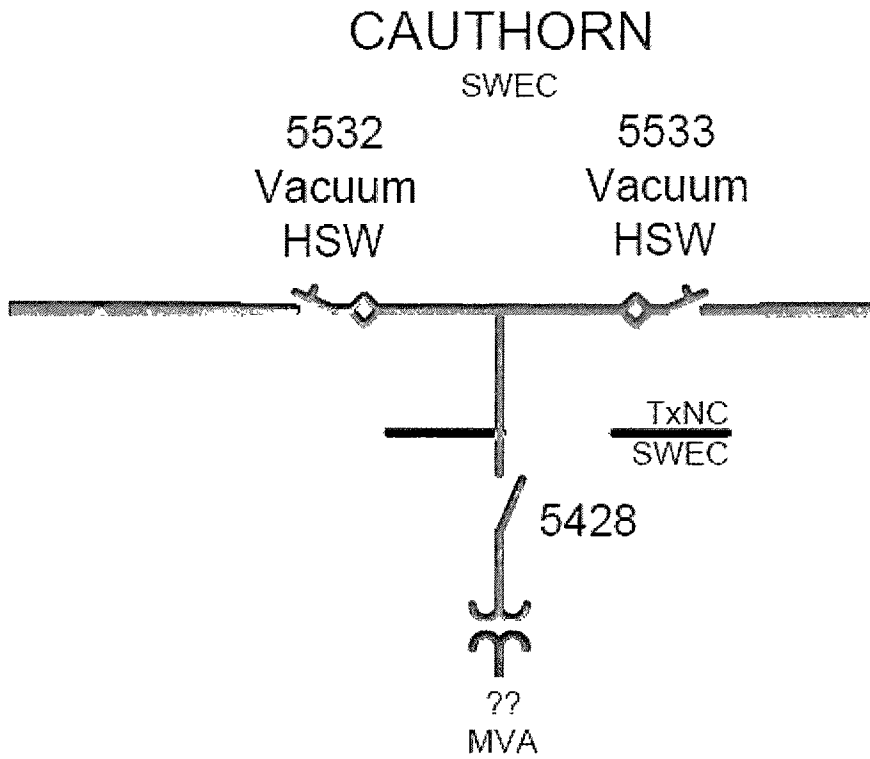

FACILITY SCHEDULE NO. 6

- 1. **Name:** Eldorado
- 2. **Facility Location:** Point of Interconnection (“POI”) is located east of Eldorado, Texas, in Schleicher County, north side of and adjacent to Highway 190, behind the Highway Dept. buildings. More specifically, the POI is where Company’s jumpers physically connect to Cooperative’s distribution conductors terminated on the meter pole.
- 3. **Delivery Voltage:** 12.5 kV
- 4. **Metered Voltage:** 12.5 kV
- 5. **Loss Adjustment Due To Meter Location:** No
- 6. **Normal Operation of Interconnection:** Closed
- 7. **One-Line Diagram Attached:** Yes
- 8. **Facilities Ownership Responsibilities of the Parties:**
 - A. **Company owns the following facilities:**
 - i. the distribution feeder facilities on the source side of this POI
 - ii. the meter pole and associated metering equipment
 - B. **Cooperative owns the following facilities:**
 - i. the switch and remaining feeder facilities on the load side of this POI
- 9. **Operation Responsibilities of Each Party:**
Each Party will operate the facilities it owns.
- 10. **Maintenance Responsibilities of Each Party:**
Each Party will maintain the facilities it owns at its expense.
- 11. **Estimated Peak Load:** 2,969 kW
- 12. **Other Terms and Conditions:** None

[The remainder of this page intentionally left blank]

FACILITY SCHEDULE NO. 6 (continued) One-Line Diagram

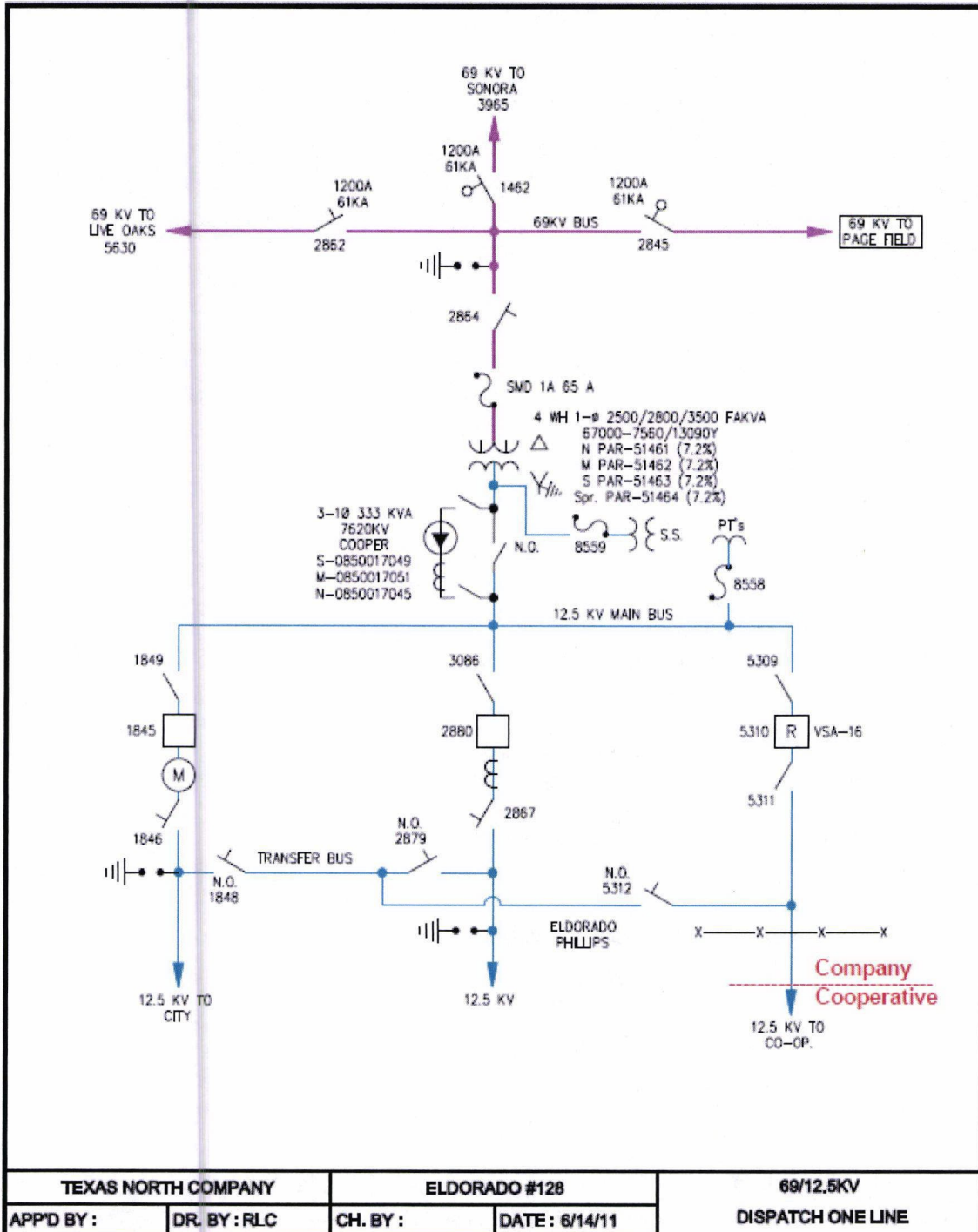

FACILITY SCHEDULE NO. 7

1. **Name:** Girvin
2. **Facility Location:** The Point of Interconnection (“POI”) is 18 miles west of McCamey, Texas in Upton County, on US Hwy 67, then northwest on Sun Valley Rd. 6.5 miles, then northeast 1.7 miles to Company’s Sun Valley Substation (“Substation”), then 50 feet west of Substation at the meter pole. More specifically, the POI is where Company’s jumpers physically connect to Cooperative’s distribution conductors terminated on the meter pole.
3. **Delivery Voltage:** 12.5 kV
4. **Metered Voltage:** 12.5 kV
5. **Loss Adjustment Due To Meter Location:** No
6. **Norman Operation of Interconnection:** Closed
7. **One-Line Diagram Attached:** Yes
8. **Facilities Ownership Responsibilities of the Parties:**
 - A. **Company owns the following facilities:**
 - i. the Substation and all the facilities within it
 - ii. the distribution feeder facilities on the source side of this POI
 - iii. the meter pole and associated metering equipment
 - B. **Cooperative owns the following facilities:**
 - i. the distribution feeder facilities on the load side of this POI
9. **Operation Responsibilities of Each Party:**

Each Party will operate the facilities it owns.
10. **Maintenance Responsibilities of Each Party:**

Each Party will maintain the facilities it owns at its own expense.
11. **Estimated Peak Load:** 259 kW
12. **Other Terms and Conditions:** None

[The remainder of this page intentionally left blank]

FACILITY SCHEDULE NO. 7 (continued) One-Line Diagram

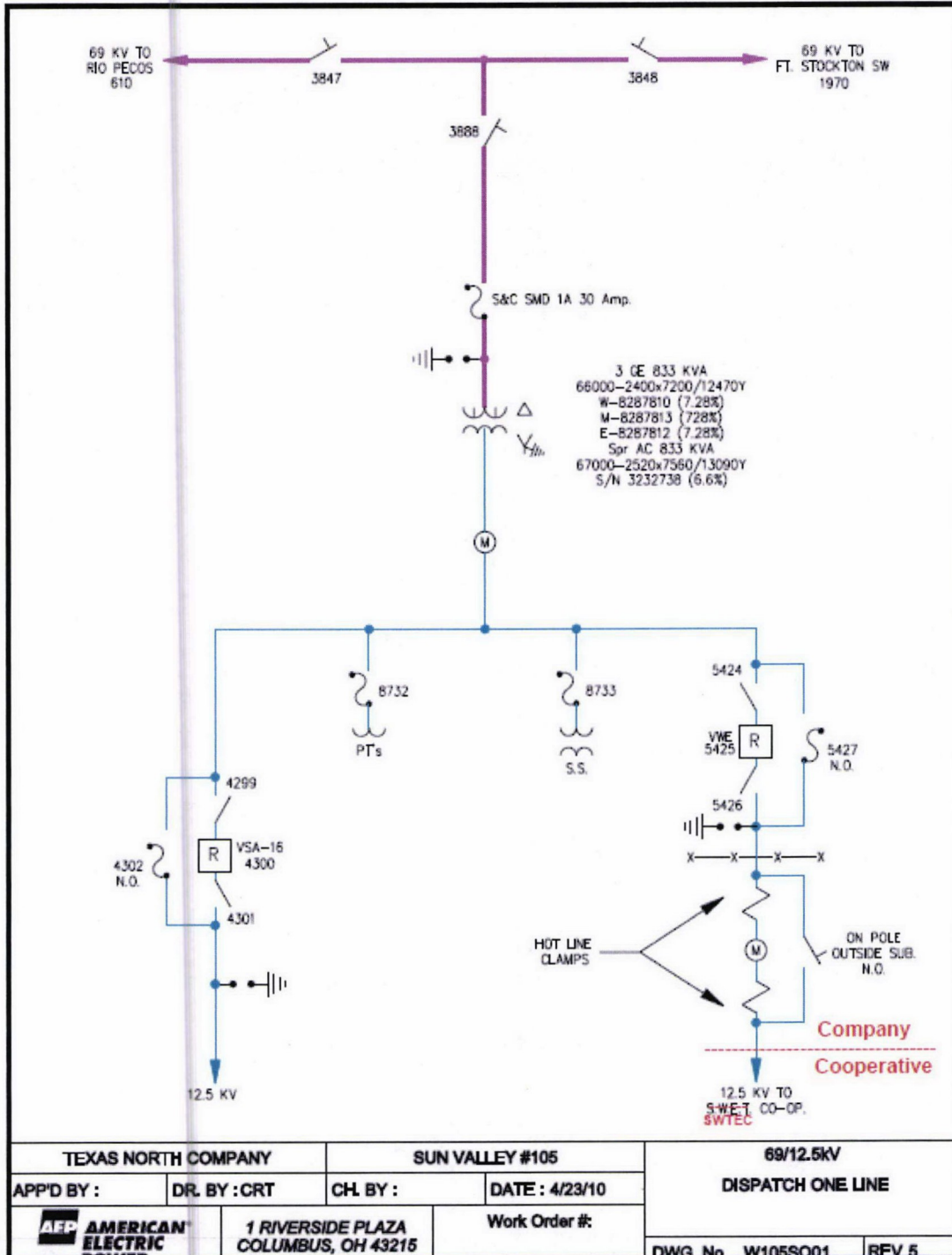

FACILITY SCHEDULE NO. 8

1. **Name:** **Hulldale**
2. **Facility Location:** The Point of Interconnection (“POI”) is at the Cooperative’s Hulldale Substation (“Substation”), approximately ten (10) miles north of Eldorado, TX, in Schleicher County, east and adjacent to Highway 277. More specifically, the POI is where the Company’s jumper conductors from the Live Oaks Eldorado to Concho 69 kV transmission line physically connect to the Substation equipment.
3. **Delivery Voltage:** 69 kV
4. **Metered Voltage:** 12.5 kV
5. **Loss Adjustment Due To Meter Location:** No
6. **Normal Operation of Interconnection:** Closed
7. **One-Line Diagram Attached:** Yes
8. **Facilities Ownership Responsibilities of the Parties:**
 - A. **Company owns the following facilities:**
 - i. the Live Oaks Eldorado to Concho 69 kV transmission line
 - ii. the in-line switches (3083 and 3088) in the Live Oaks Eldorado to Concho 69 kV transmission line
 - B. **Cooperative owns the following facilities:**
 - i. the Substation and all the facilities within it
9. **Operation Responsibilities of Each Party:**

Each Party will operate the facilities it owns.
10. **Maintenance Responsibilities of Each Party:**

Each Party will maintain the facilities it owns at its own expense.
11. **Estimated Peak Load:** 1,170 kW
12. **Other Terms and Conditions:**
 - i. Company is to have access to switch (5333)
 - ii. PT & CT sold to Cooperative

[The remainder of this page intentionally left blank]

FACILITY SCHEDULE NO. 8 (continued)
One-Line Diagram

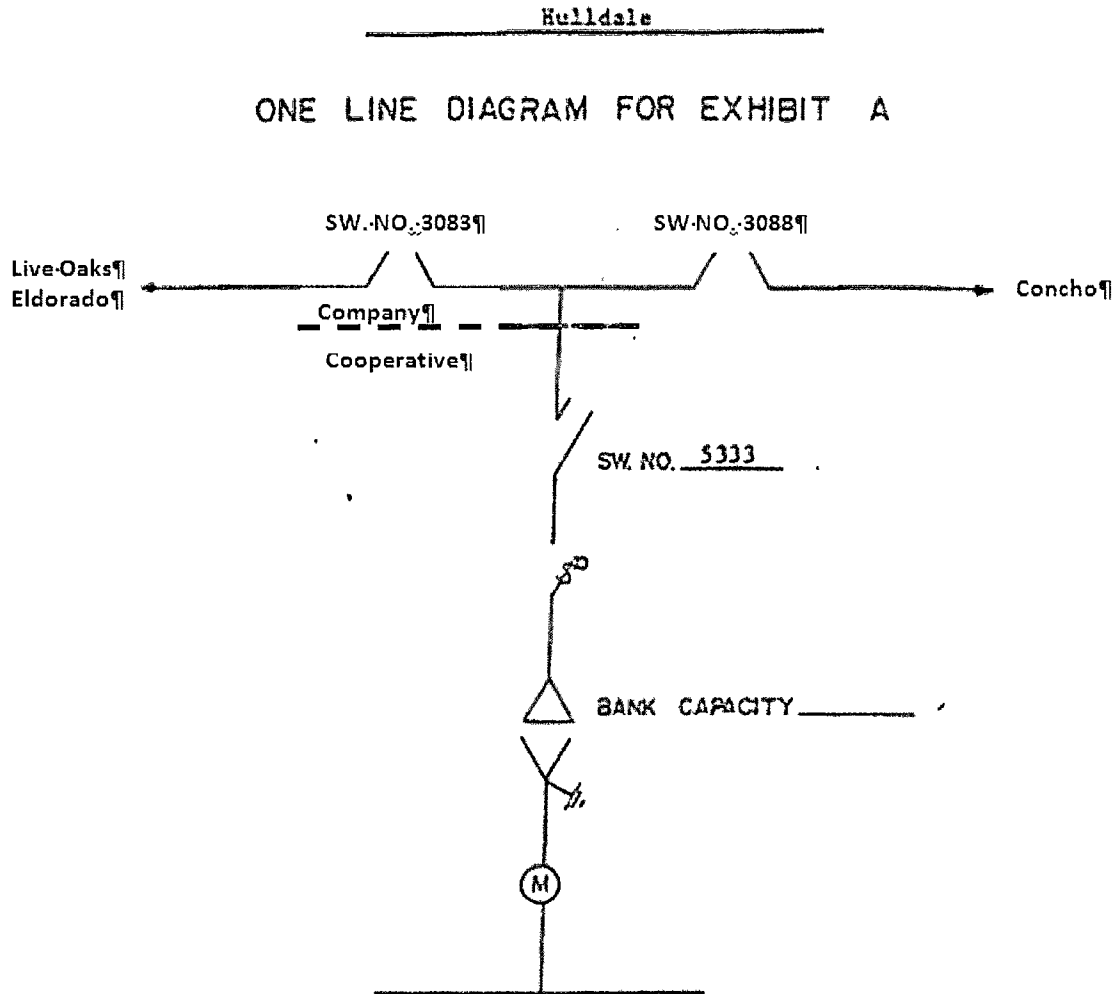

FACILITY SCHEDULE NO. 9

1. **Name:** Menard
2. **Facility Location:** The Point of Interconnection (“POI”) is two (2) miles west of Menard, TX, in Menard County, adjacent to Highway 190. More specifically, the POI is where Company’s jumpers physically connect to Cooperative’s distribution conductors terminated on the meter pole.
3. **Delivery Voltage:** 12.5 kV
4. **Metered Voltage:** 12.5 kV
5. **Loss Adjustment Due To Meter Location:** No
6. **Normal Operation of Interconnection:** Closed
7. **One-Line Diagram Attached:** Yes
8. **Facilities Ownership Responsibilities of the Parties:**
 - A. **Company owns the following facilities:**
 - i. the Menard substation and all the facilities within it
 - ii. the distribution feeder facilities from the Menard substation to the source side of the POI
 - iii. the meter pole and associated metering equipment
 - iv. the oil circuit recloser (R95702)
 - B. **Cooperative owns the following facilities:**
 - i. the distribution feeder facilities on the load side of the POI
9. **Operation Responsibilities of Each Party:**
Each Party will operate the facilities it owns.
10. **Maintenance Responsibilities of Each Party:**
Each Party will maintain the facilities it owns at its own expense.
11. **Estimated Peak Load:** 1,211 kW
12. **Other Terms and Conditions:**
Cooperative is to have access to OCR (R95702)

[The remainder of this page intentionally left blank]

FACILITY SCHEDULE NO. 9 (continued)
One-Line Diagram

Menard

ONE LINE DIAGRAM FOR EXHIBIT A

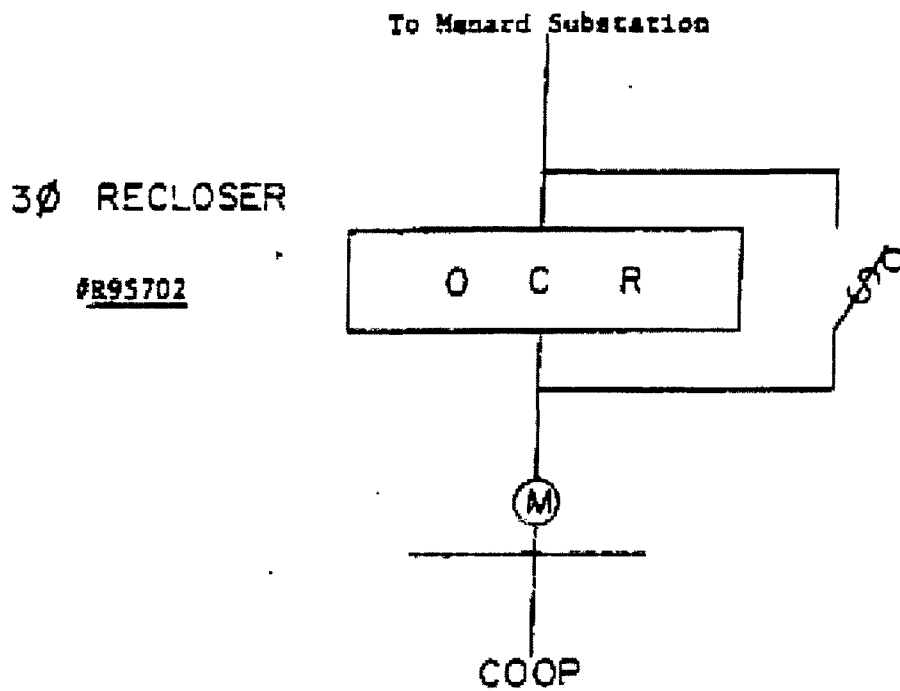

1. Southwest Texas Electric Co-op is to have access to OCR #R95702.
2. Dashed line indicates change of ownership.

25

FACILITY SCHEDULE NO. 10

1. **Name:** Mertzon
2. **Facility Location:** The Point of Interconnection (“POI”) is approximately eight (8) miles east of Mertzon, TX, in Irion County on the main road through the Brooks Oil Field, a quarter (.25) mile north. More specifically, the POI is where Company’s jumpers physically connect to Cooperative’s distribution conductors terminated on the meter pole.
3. **Delivery Voltage:** 12.5 kV
4. **Metered Voltage:** 12.5 kV
5. **Loss Adjustment Due To Meter Location:** No
6. **Normal Operation of Interconnection:** Closed
7. **One-Line Diagram Attached:** Yes
8. **Facilities Ownership Responsibilities of the Parties:**
 - A. **Company owns the following facilities:**
 - i. the Mertzon substation and all the facilities within it
 - ii. the distribution feeder facilities from the Mertzon substation to the source side of the POI
 - iii. the meter pole and associated metering equipment
 - iv. the oil circuit recloser (R91302)
 - B. **Cooperative owns the following facilities:**
 - i. the distribution feeder facilities on the load side of the POI
9. **Operation Responsibilities of Each Party:**

Each Party will operate the facilities it owns.
10. **Maintenance Responsibilities of Each Party:**

Each Party will maintain the facilities it owns at its own expense.
11. **Estimated Peak Load:** 423 kW
12. **Other Terms and Conditions:**

Cooperative is to have access to OCR (R91302)

[The remainder of this page intentionally left blank]

FACILITY SCHEDULE NO. 10 (continued)
One-Line Diagram

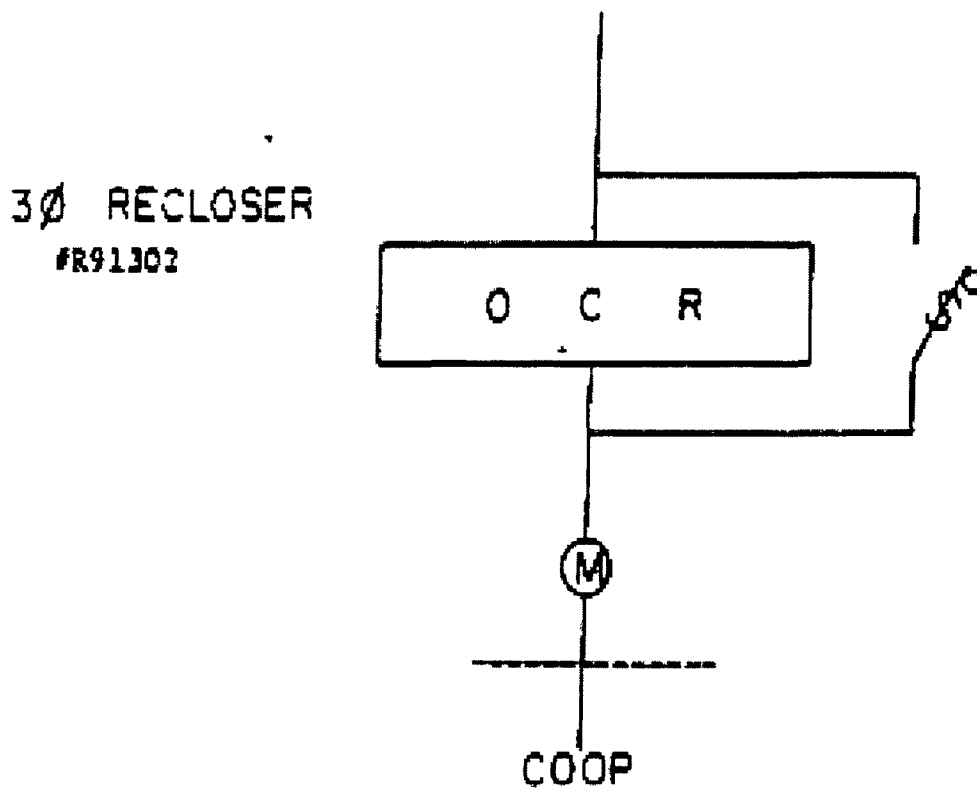

1. Southwest Texas Electric Coop is to have access to OCR R91302.
2. Dashed line indicates point of change in ownership.

FACILITY SCHEDULE NO. 11

1. **Name:** Middle Valley
2. **Facility Location:** The Point of Interconnection (“POI”) is in Cooperative’s Middle Valley Substation (“Substation”). More specifically, the POI is where the Company’s jumper conductors from the Live Oaks Eldorado radial 69 kV transmission line physically connect to the Substation equipment.
3. **Delivery Voltage:** 69 kV
4. **Metered Voltage:** 12.5 kV and 24.9 kV
5. **Loss Adjustment Due To Meter Location:** No
6. **Normal Operation of Interconnection:** Closed
7. **One-Line Diagram Attached:** Yes
8. **Facilities Ownership Responsibilities of the Parties:**
 - A. **Company owns the following facilities:**
 - i. the Live Oaks Eldorado radial 69 kV transmission line
 - ii. the in-line switch (5418) in the Live Oaks Eldorado radial 69 kV transmission line
 - B. **Cooperative owns the following facilities:**
 - i. the Substation and all the facilities within it
9. **Operation Responsibilities of Each Party:**

Each Party will operate the facilities it owns.
10. **Maintenance Responsibilities of Each Party:**

Each Party will maintain the facilities it owns at its expense.
11. **Estimated Peak Load:** 605 kW (12.5 kV); 321 kW (24.9 kV)
12. **Other Terms and Conditions:**
 - i. Company is to have access to switches (5408 and 5413)
 - ii. PT & CT sold to Cooperative

[The remainder of this page intentionally left blank]

FACILITY SCHEDULE NO. 11 (continued)
One-Line Diagram

Middle Valley Substation

ONE LINE DIAGRAM FOR EXHIBIT A

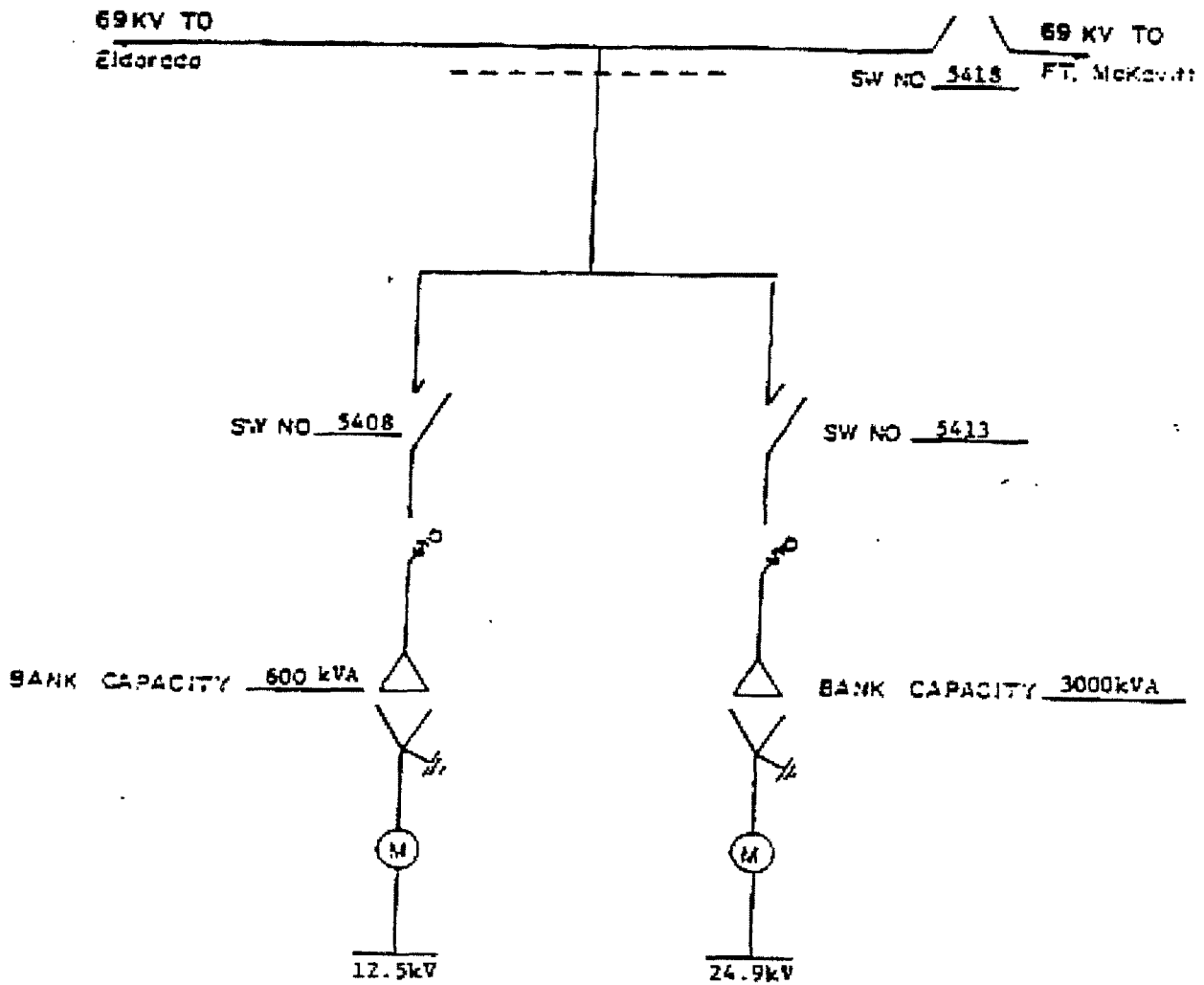

1. Dashed line indicates point of change in ownership.
2. Is to have access to switches # 5408 and # 5413.

FACILITY SCHEDULE NO. 13

1. **Name:** **Midway Lane**
2. **Facility Location:** The Company’s Midway Lane Substation (“AEP Substation”) is located south of Big Lake, Texas, on Highway 137, then east three (3) miles on Highway 190 and one-hundred (100) yards south of Highway 190, in Crockett County. There are two (2) Points of Interconnection within the Substation at 1) the load-side disconnect switch (5391) and normally open fuse (5392), identified as the South Circuit; and 2) the load-side disconnect switch (55401) and normally open fuse (5402), identified as the North Circuit. More specifically, the Points of Interconnection are where the Company’s jumper conductors from the AEP Substation equipment physically connect to Cooperative’s distribution feeder conductors.
3. **Delivery Voltage:** 12.5 kV
4. **Metered Voltage:** 12.5 kV
5. **Loss Adjustment Due To Meter Location:** No
6. **Norman Operation of Interconnection:** Closed
7. **One-Line Diagram Attached:** Yes
8. **Facilities Ownership Responsibilities of the Parties:**
 - A. **Company owns the following facilities:**
 - i. the Substation and all the facilities within it
 - B. **Cooperative owns the following facilities:**
 - i. the South Circuit 12.5 kV distribution feeder
 - ii. the North Circuit 12.5 kV distribution feeder
9. **Operation Responsibilities of Each Party:**

See Operating Agreement for Midway Lane Cooperative Point of Delivery July 30, 1999 (“Operating Agreement”) (AFTER ONE-LINE DIAGRAM BELOW).
10. **Maintenance Responsibilities of Each Party:**

Each Party will maintain the facilities it owns at its own expense.
11. **Estimated Peak Load:** 7,562 kW
12. **Other Terms and Conditions:**
 - i. SWTEC may have access to the AEP Substation as long as SWTEC maintains its AEP Switching and Tagging training requirements
 - ii. SWTEC personnel will call AEP Texas Distribution Dispatch Center (“DDC”) to log in and out, before entering and leaving the AEP Substation.
 - iii. SWTEC is to have access to OCR (5390 and 5400)

- iv. SWTEC is to have access to load-side disconnect switches (5391 and 5401)
- v. Before operating and switching AEP's OCR (5390 and 5400) and load-side disconnect switches (5391 and 5401) pursuant to SWTEC Section 2, 3, 4, and 6 of the Operating Agreement, SWTEC shall first receive operating and switching instructions from the DDC.

[The remainder of this page intentionally left blank]

FACILITY SCHEDULE NO. 13 (continued) One-Line Diagram

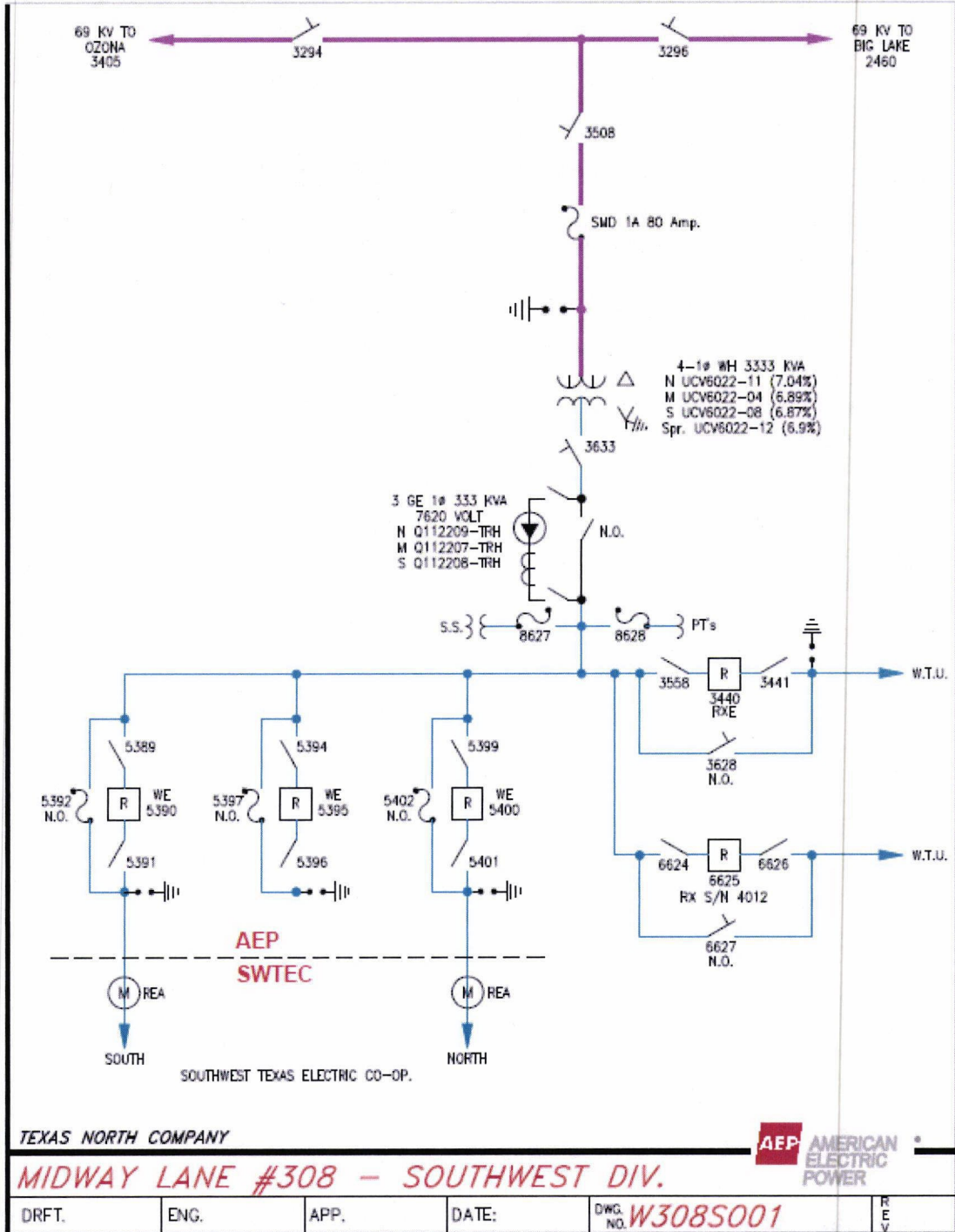

FACILITY SCHEDULE NO. 13 (continued)

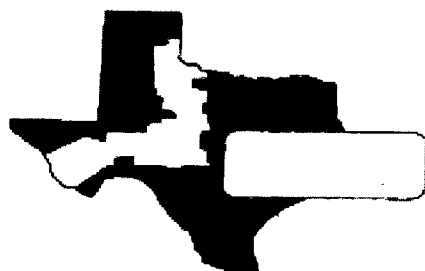

Transmission & Distribution Operations
Dispatch Operations -

Subject: Southwest Texas Electric Co-op – Midway Lane Point of Delivery Operating Procedure

**OPERATING AGREEMENT FOR MIDWAY LANE SWTEC POINT OF DELIVERY
July 30, 1999 (supersedes all previous operating agreements)**

SOUTH WEST TEXAS ELECTRIC COOPERATIVE

1. Southwest Texas Electric Cooperative (SWTEC) shall have access to Midway Lane Substation to operate OCR 5390, and 5400 and line side disconnects 5391, , and 5401.
 2. SWTEC may operate OCR 5390, and 5400 using the operator on each recloser.
 3. If SWTEC closes the recloser after the recloser is locked out, WTU's Dispatch Operations Dispatcher shall be notified in a timely manner.
 4. SWTEC may operate line-side disconnect switches 5391, and 5401 after obtaining switching instructions from WTU's Dispatch Operations.
 5. If SWTEC takes a planned clearance on this circuit, WTU's Dispatch Operations shall be notified in advance of the clearance.
 6. SWTEC shall notify WTU's Dispatch Operations of the times when a switch or recloser in the substation was operated.
-
1. WTU shall notify SWTEC of any planned outages or work at the Midway Lane Substation prior to the time that work is to be done.
 2. WTU shall not close OCR's 5390, and 5400 to pick up load without specific instructions from SWTEC to do so.
 3. WTU shall not transfer load to another recloser without first notifying SWTEC of the planned transfer.
 4. WTU shall make provisions for SWTEC to access the Midway Lane Substation.

FACILITY SCHEDULE NO. 13 (continued)

Subject: Southwest Texas Electric Co-op - Midway Lane Point of Delivery Operating Procedure

**OPERATING AGREEMENT FOR MIDWAY LANE SWTEC POINT OF DELIVERY
July 30, 1999 (supersedes all previous operating agreements)**

IN WITNESS WHEREOF, COMPANY and Customer have caused this Agreement to be executed in duplicate in their names by their respective duly authorized representatives as of the date and year first above written.

SOUTHWEST TEXAS ELECTRIC COOPERATIVE, INC.

CUSTOMER

ATTEST:

Jack Williams

By: William W. Whitten
General Manager

COMPANY

ATTEST:

Martha Murray

By: Dual R. Jester P.E.
Director, Transmission & Distribution
Operations

FACILITY SCHEDULE NO. 14

1. **Name:** North Sonora
2. **Facility Location:** The Point of Interconnection (“POI”) is located at the north end of the Company’s 12.5 kV, 3 phase distribution line which terminates at the Company - Cooperative certification boundary three and a half (3.5) mi. north of Sonora, TX, and one and a half (1.5) miles west of Highway 277 in Sutton County. More specifically, the POI is where Company’s jumpers physically connect to Cooperative’s distribution conductors terminated on the meter pole.
3. **Delivery Voltage:** 12.5 kV
4. **Metered Voltage:** 12.5 kV
5. **Loss Adjustment Due To Meter Location:** No
6. **Norman Operation of Interconnection:** Closed
7. **One-Line Diagram Attached:** Yes
8. **Facilities Ownership Responsibilities of the Parties:**
 - A. **Company owns the following facilities:**
 - i. the Sonora substation and all the facilities within it
 - ii. the distribution feeder facilities from the Sonora substation to the source side of the POI
 - iii. the meter pole and associated metering equipment
 - iv. the oil circuit recloser (R91710)
 - B. **Cooperative owns the following facilities:**
 - i. the distribution feeder facilities on the load side of the POI
9. **Operation Responsibilities of Each Party:**

Each Party will operate the facilities it owns.
10. **Maintenance Responsibilities of Each Party:**

Each Party will maintain the facilities it owns at its own expense.
11. **Estimated Peak Load:** 742 kW
12. **Other Terms and Conditions:**

Cooperative is to have access to OCR (R91710)

[The remainder of this page intentionally left blank]

FACILITY SCHEDULE NO. 14 (continued)
One-Line Diagram

SOUTHWEST TEXAS ELECTRIC CO-OP NORTH SONORA METER POINT

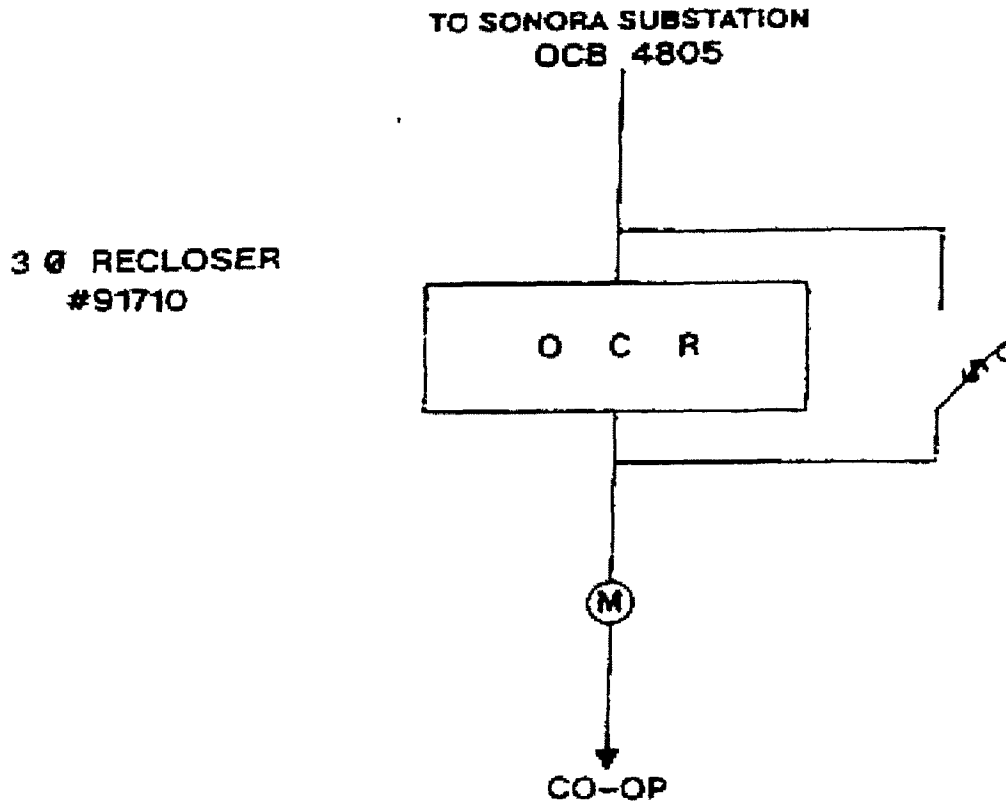

1. SOUTHWEST TEXAS ELECTRIC CO-OP IS TO HAVE ACCESS TO OCR #91710
2. OCR #91710 WILL BE INSTALLED ONE SPAN SOUTH OF THE METER POINT ON A POLE.

LOCATION: AT THE NORTH END OF A WEST TEXAS UTILITIES 12.5 KV, 3 PHASE POWER LINE WHICH TERMINATES AT THE - SWTEC CERTIFICATION BOUNDARY 3 1/2 MI. NORTH OF SONORA AND 1/2 MI. WEST OF HWY 277 IN SUTTON COUNTY.

FACILITY SCHEDULE NO. 16

1. **Name:** Powell Field
2. **Facility Location:** The Point of Interconnection (“POI”) is at the meter pole approximately one hundred twenty-five (125) feet southwest of Company’s Power Field Substation (“Substation”) which is located approximately four (4) miles west of Big Lake, Texas, on US 67, then south on Ranch 1676 Spur County Road for thirteen (13) miles, in Crockett County. More specifically, the POI is where the Company’s jumper conductors physically connect to Cooperative’s distribution conductors terminating on the meter pole.
3. **Delivery Voltage:** 12.5 kV
4. **Metered Voltage:** 12.5 kV
5. **Loss Adjustment Due To Meter Location:** No
6. **Normal Operation of Interconnection:** Closed
7. **One-Line Diagram Attached:** Yes
8. **Facilities Ownership Responsibilities of the Parties:**
 - A. **Company owns the following facilities:**
 - i. the Substation and all the facilities within it
 - ii. approximately 125 feet of 12.5 kV distribution feeder serving the POI
 - iii. the meter pole
 - iv. the metering facilities
 - B. **Cooperative owns the following facilities:**
 - i. the facilities on the load-side of the meter
9. **Operation Responsibilities of Each Party:**

Each Party will operate the facilities it owns.
10. **Maintenance Responsibilities of Each Party:**

Each Party will maintain the facilities it owns at its own expense.
11. **Estimated Peak Load:** 926 kW
12. **Other Terms and Conditions:**
 - i. Cooperative is to have access to OCR 5410 and load side disconnect switch 5411
 - ii. Recloser 5410 is leased from Cooperative

FACILITY SCHEDULE NO. 17

1. **Name:** **Sheffield**
2. **Facility Location:** The Point of Interconnection (“POI”) is on a 12.5 kV meter pole outside the Company’s Sheffield Substation (“Substation”), north side of Hwy 10, north of Sheffield, Texas, in Pecos County. More specifically, the POI is where the Company’s jumper conductors physically connect to Cooperative’s distribution conductors terminating on the meter pole.
3. **Delivery Voltage:** 12.5 kV
4. **Metered Voltage:** 12.5 kV
5. **Loss Adjustment Due To Meter Location:** No
6. **Normal Operation of Interconnection:** Closed
7. **One-Line Diagram Attached:** Yes
8. **Facilities Ownership Responsibilities of the Parties:**
 - A. **Company owns the following facilities:**
 - i. the 12.5 kV distribution feeder from the Substation serving the POI
 - ii. the Substation and all the facilities within it
 - iii. the meter pole
 - iv. the metering facilities
 - v. the OCR (R71301)
 - B. **Cooperative owns the following facilities:**
 - i. the facilities on the load-side of the meter
9. **Operation Responsibilities of Each Party:**

Each Party will operate the facilities it owns.
10. **Maintenance Responsibilities of Each Party:**

Each Party will maintain the facilities it owns at its own expense.
11. **Estimated Peak Load:** 1,325 kW
12. **Other Terms and Conditions:**

Cooperative is to have access to OCR (R71301)

[The remainder of this page intentionally left blank]

FACILITY SCHEDULE NO. 17 (continued) One-Line Diagram

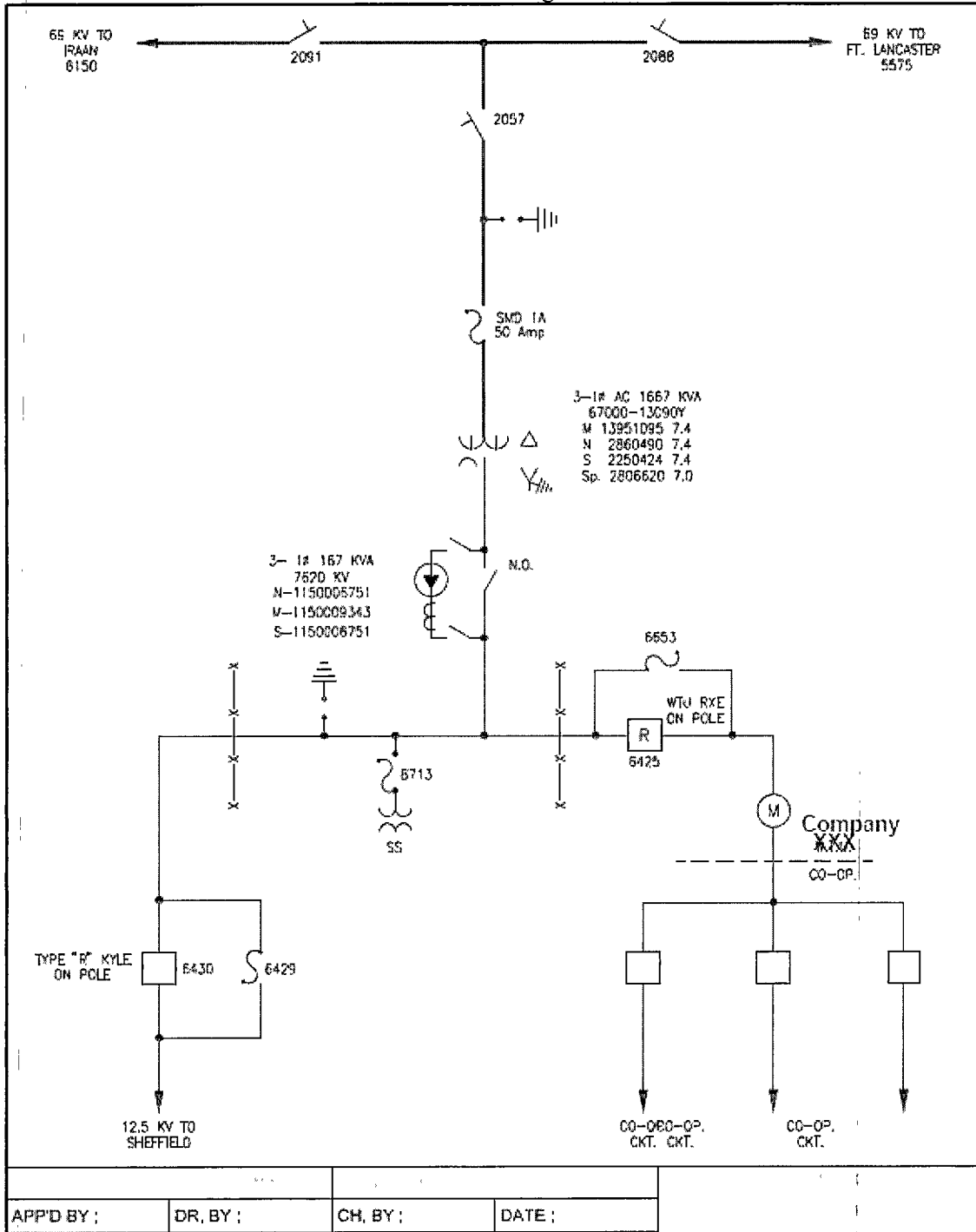

FACILITY SCHEDULE NO. 17(continued)
One-Line Diagram

SHEFFIELD SUB

ONE LINE DIAGRAM FOR EXHIBIT A

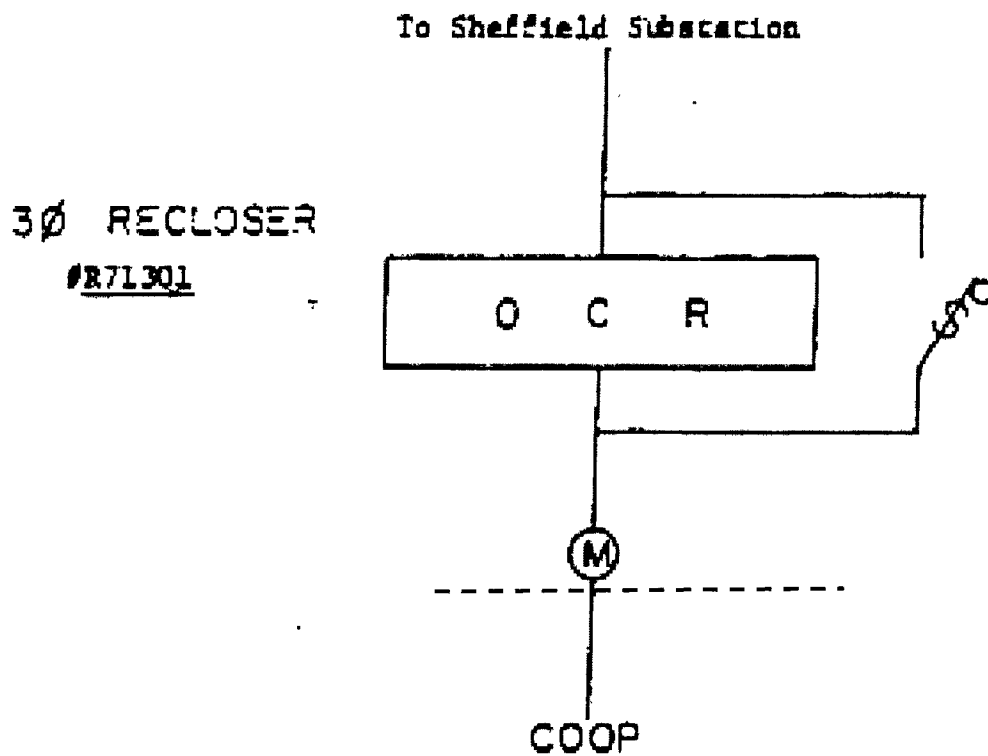

1. Southwest Texas Electric Co-op is to have access to OCR #R7L301.

FACILITY SCHEDULE NO. 18

1. **Name:** Sonora
2. **Facility Location:** The Point of Interconnection (“POI”) is near the south edge of Sonora, Texas, a quarter (0.25) mile off Highway 277 on the east side. More specifically, the POI is where the Company’s jumper conductors physically connect to Cooperative’s distribution conductors terminating on the meter pole.
3. **Delivery Voltage:** 12.5 kV
4. **Metered Voltage:** 12.5 kV
5. **Loss Adjustment Due To Meter Location:** No
6. **Normal Operation of Interconnection:** Closed
7. **One-Line Diagram Attached:** Yes
8. **Facilities Ownership Responsibilities of the Parties:**
 - A. **Company owns the following facilities:**
 - i. the 12.5 kV distribution feeder from the Sonora Substation (“Substation”) serving the POI
 - ii. the Substation and all the facilities within it
 - iii. the meter pole
 - iv. the metering facilities
 - v. the OCR (R91701)
 - B. **Cooperative owns the following facilities:**
 - i. the facilities on the load-side of the meter
9. **Operation Responsibilities of Each Party:**

Each Party will operate the facilities it owns.
10. **Maintenance Responsibilities of Each Party:**

Each Party will maintain the facilities it owns at its expense.
11. **Estimated Peak Load:** 1,921 kW
12. **Other Terms and Conditions:**

Cooperative is to have access to OCR R91701

[The remainder of this page intentionally left blank]

FACILITY SCHEDULE NO. 18 (continued)
One-Line Diagram

SONORA 138/69/12 KV

ONE LINE DIAGRAM FOR EXHIBIT A

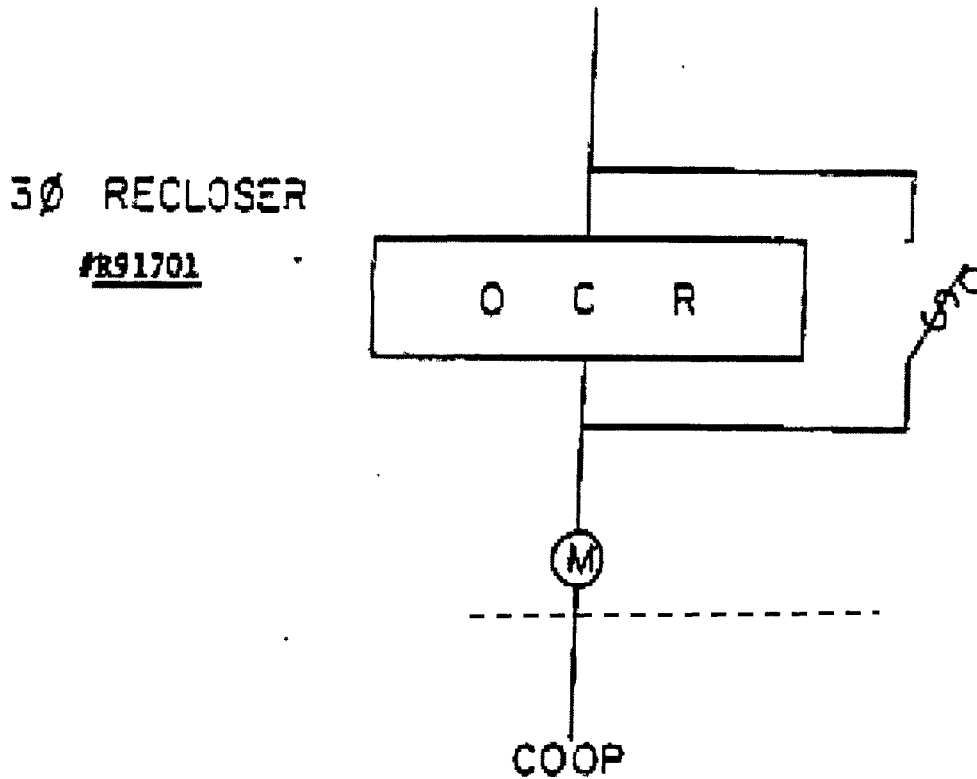

1. Southwest Texas Electric Co-op is to have access to OCR #R91701.

FACILITY SCHEDULE NO. 19

1. **Name:** Sonora Atlantic
2. **Facility Location:** The Point of Interconnection (“POI”) is at the Company’s Atlantic Sonora Substation (“Substation”), approximately twelve (12) miles west of Sonora, Texas, in Sutton County, on Old Sonora to Ozona Highway 290. More specifically, the POI is where the Company’s jumper conductors from the Substation equipment physically connect to Cooperative’s distribution feeder conductors.
3. **Delivery Voltage:** 12.5 kV
4. **Metered Voltage:** 12.5 kV
5. **Loss Adjustment Due To Meter Location:** No
6. **Normal Operation of Interconnection:** Closed
7. **One-Line Diagram Attached:** Yes
8. **Facilities Ownership Responsibilities of the Parties:**
 - A. **Company owns the following facilities:**
 - i. the Substation and all the facilities within it
 - B. **Cooperative owns the following facilities:**
 - i. the 12.5 kV distribution feeder
9. **Operation Responsibilities of Each Party:**

Each Party operates the facilities it owns.
10. **Maintenance Responsibilities of Each Party:**

Each Party maintains the facilities it owns at its own expense.
11. **Estimated Peak Load:** 854 kW
12. **Other Terms and Conditions:**
 - i. Cooperative is to have access to OCR (5420)
 - ii. Cooperative is to have access to load side disconnect switch (5421)

[The remainder of this page intentionally left blank]

FACILITY SCHEDULE NO. 19 (continued) One-Line Diagram

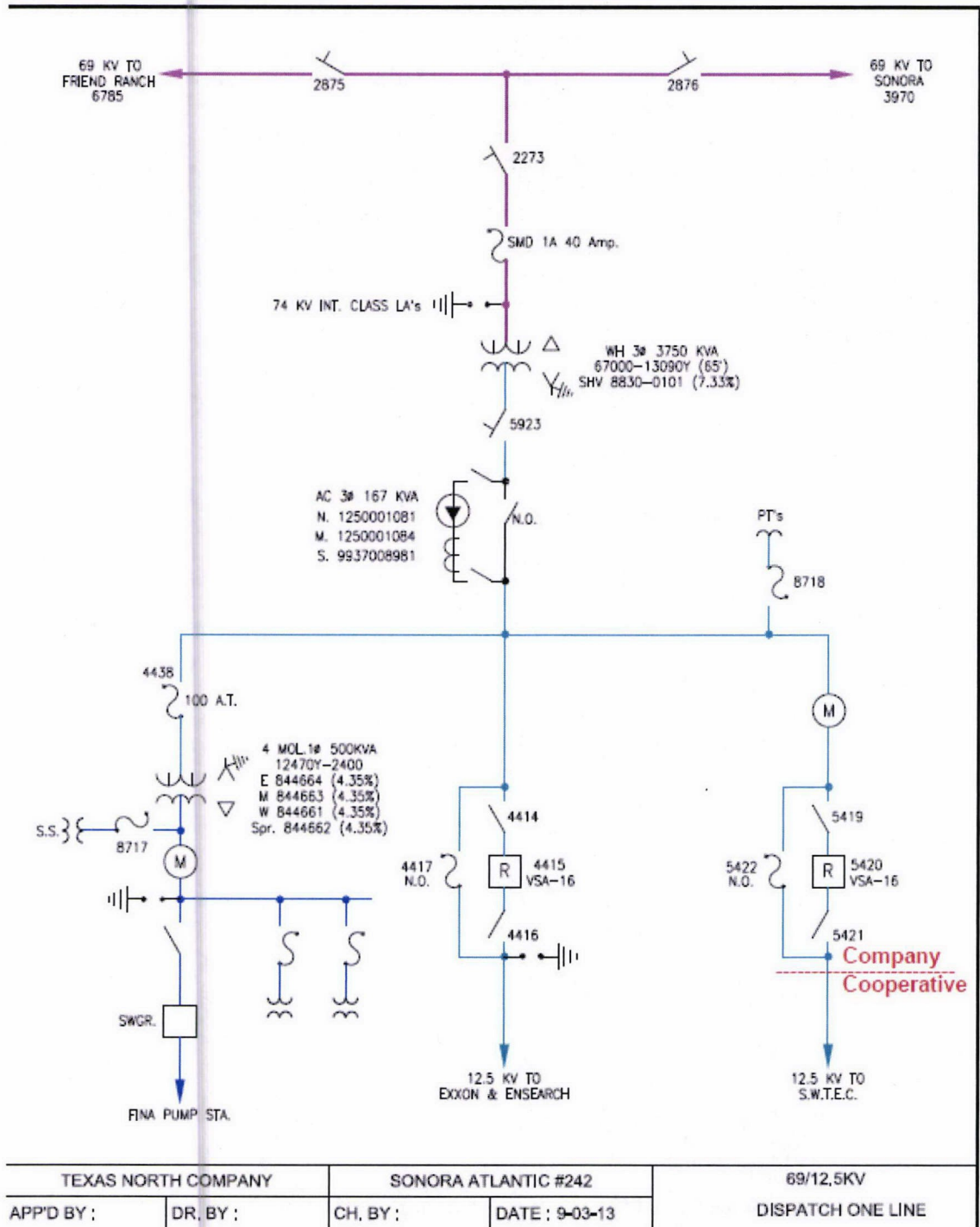

FACILITY SCHEDULE NO. 20

1. **Name:** Strauss Ranch
2. **Facility Location:** The Point of Interconnection (“POI”) is in Cooperative’s Strauss Ranch Substation (“Substation”), 10.4 miles south of Big Lake, Texas, Reagan County, on eastside and adjacent to Hwy 137. More specifically, the POI is located within the Substation at the high-side connection of the radial in-line disconnect switch (5328).
3. **Delivery Voltage:** 69 kV
4. **Metered Voltage:** 12.5 kV
5. **Loss Adjustment Due To Meter Location:** No
6. **Normal Operation of Interconnection:** Closed
7. **One-Line Diagram Attached:** Yes
8. **Facilities Ownership Responsibilities of the Parties:**
 - A. **Company owns the following facilities:**
 - i. the Ozona to Big Lake 69 kV transmission line
 - ii. the in-line switches (3533 and 3528) in the Ozona to Big Lake transmission line
 - B. **Cooperative owns the following facilities:**
 - i. the Substation and all the facilities within it
 - ii. the radial in-line disconnect switch (5328) to the Substation
9. **Operation Responsibilities of Each Party:**

Each Party will operate the facilities it owns.
10. **Maintenance Responsibilities of Each Party:**

Each Party will maintain the facilities it owns at its own expense.
11. **Estimated Peak Load:** 4,000 kW
12. **Other Terms and Conditions:**
 - i. Company is to have access to switch 5328
 - ii. PT & CT sold to Cooperative

[The remainder of this page intentionally left blank]

FACILITY SCHEDULE NO. 20 (continued)
One-Line Diagram

Scraugs

ONE LINE DIAGRAM FOR EXHIBIT A

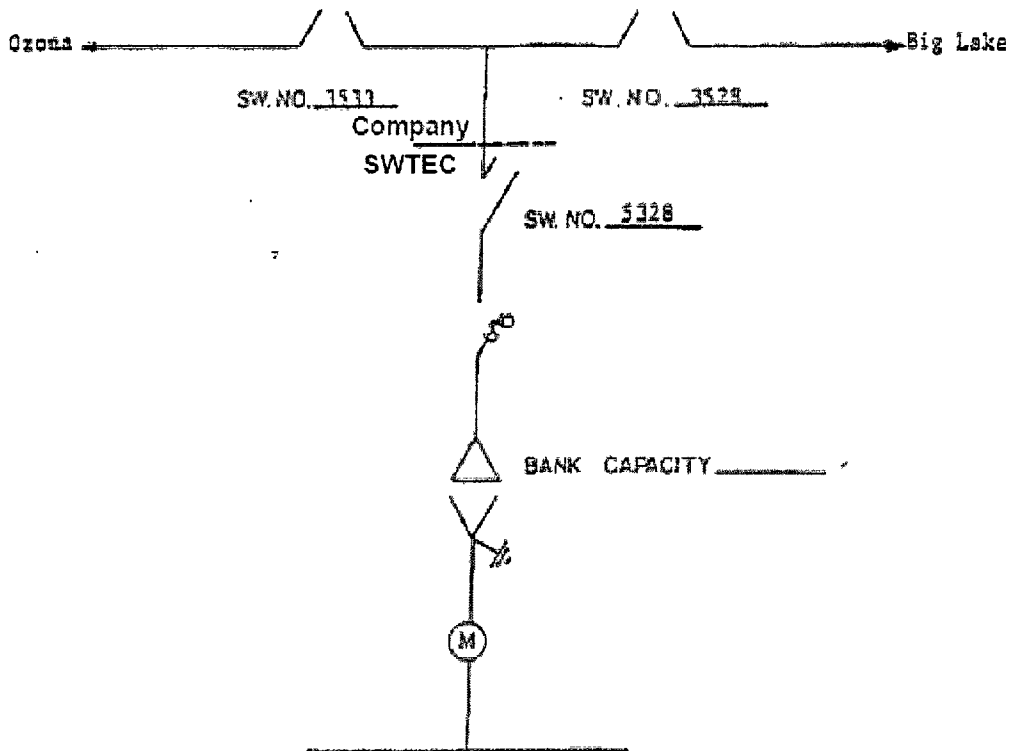

Company

1. XXX is to have access to bank switch #5128.
2. Dashed line indicates change of ownership.

FACILITY SCHEDULE NO. 21

1. **Name:** Tippett/McCamey
2. **Facility Location:** The Point of Interconnection (“POI”) is approximately ten (10) miles south of McCamey, Texas, in Pecos County, on Country Road 305. More specifically, the POI is where the Company’s jumper conductors physically connect to Cooperative’s distribution conductors terminating on the meter pole.
3. **Delivery Voltage:** 12.5 kV
4. **Metered Voltage:** 12.5 kV
5. **Loss Adjustment Due To Meter Location:** No
6. **Normal Operation of Interconnection:** Closed
7. **One-Line Diagram Attached:** Yes
8. **Facilities Ownership Responsibilities of the Parties:**
 - A. **Company owns the following facilities:**
 - i. the 12.5 kV distribution feeder from the Company’s McCamey substation serving the POI
 - ii. the meter pole
 - iii. the metering facilities
 - B. **Cooperative owns the following facilities:**
 - i. the facilities on the load-side of the meter
9. **Operation Responsibilities of Each Party:**

Each Party will operate the facilities it owns.
10. **Maintenance Responsibilities of Each Party:**

Each Party will maintain the facilities it owns at its own expense.
11. **Estimated Peak Load:** 274 kW
12. **Other Terms and Conditions:**

On Primary Substation Rate

[The remainder of this page intentionally left blank]

FACILITY SCHEDULE NO. 21(continued)
One-Line Diagram

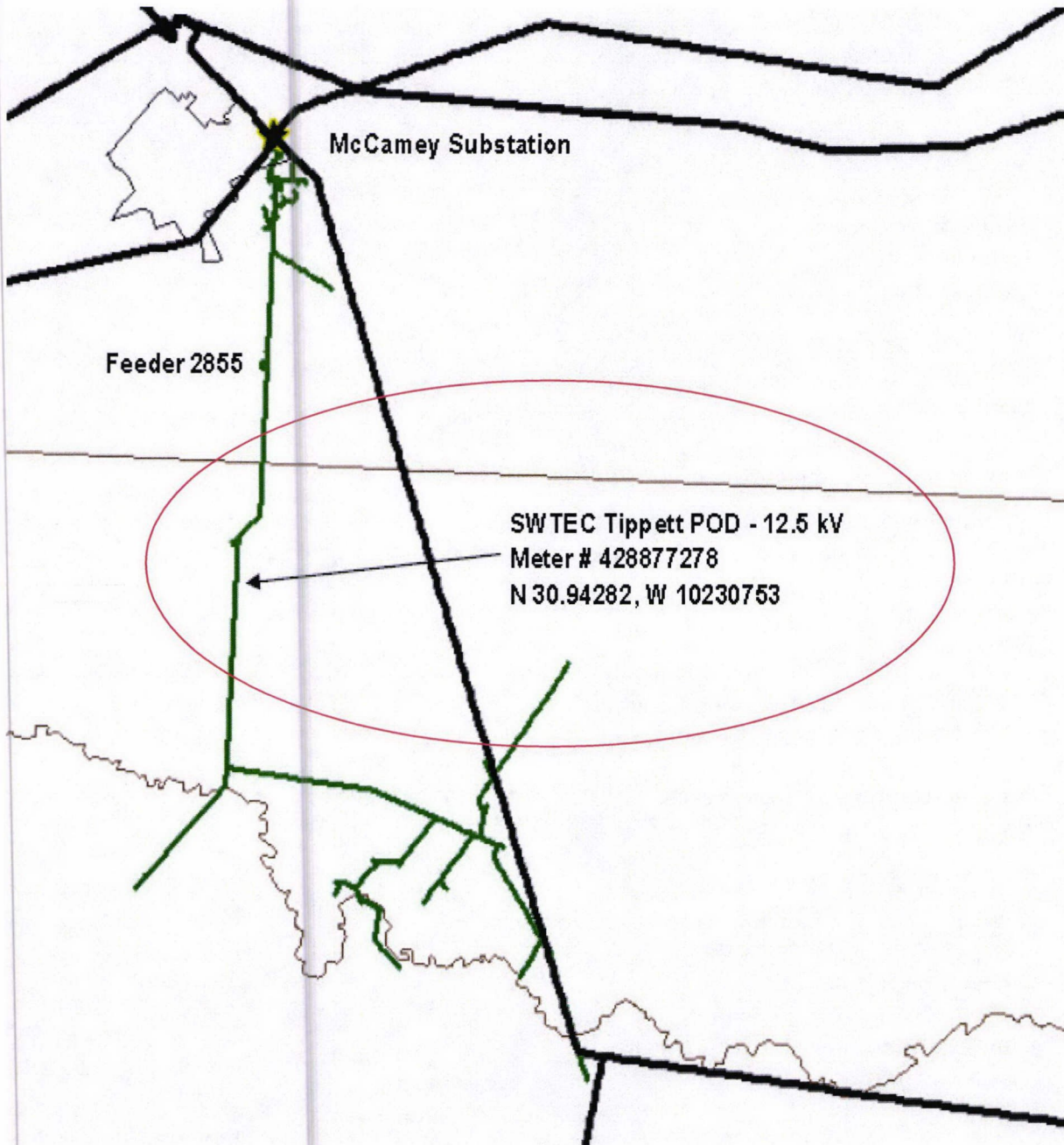

FACILITY SCHEDULE NO. 22

1. **Name:** Walker Field/Mesa View
2. **Facility Location:** The Point of Interconnection (“POI”) is approximately fifteen (15) miles south of McCamey, Texas, in Pecos County, on Highway 305. More specifically, the POI is where the Company’s jumper conductors physically connect to Cooperative’s distribution conductors terminating on the meter pole.
3. **Delivery Voltage:** 12.5 kV
4. **Metered Voltage:** 12.5 kV
5. **Loss Adjustment Due To Meter Location:** No
6. **Normal Operation of Interconnection:** Closed
7. **One-Line Diagram Attached:** Yes
8. **Facilities Ownership Responsibilities of the Parties:**
 - A. **Company owns the following facilities:**
 - i. the 12.5 kV distribution feeder from the Company’s Mesa View substation serving the POI
 - ii. the meter pole
 - iii. the metering facilities
 - B. **Cooperative owns the following facilities:**
 - i. the 12.5 kV distribution feeder
9. **Operation Responsibilities of Each Party:**

Each Party will operate the facilities it owns.
10. **Maintenance Responsibilities of Each Party:**

Each Party will maintain the facilities it owns at its own expense.
11. **Estimated Peak Load:** 503 kW
12. **Other Terms and Conditions:**

On Primary Substation Rate

[The remainder of this page intentionally left blank]

FACILITY SCHEDULE NO. 22(continued)
One-Line Diagram

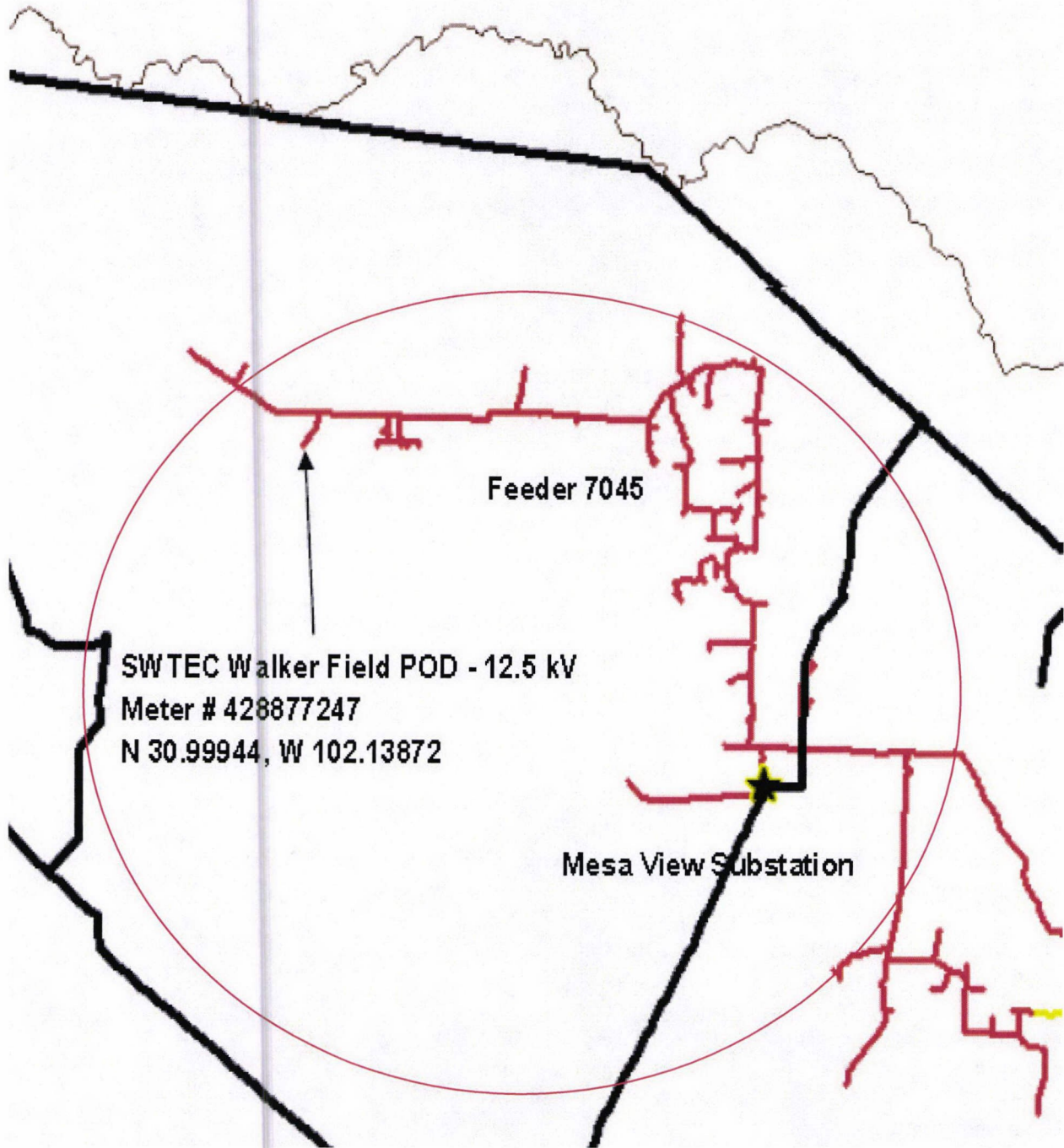

FACILITY SCHEDULE NO. 24

1. **Name:** Pecos River
2. **Facility Location:** The Cooperative's Pecos River Substation ("Substation") is located approximately 8.5 miles north of Sheffield, Texas, east of State Road 349, near the intersection of Deer Canyon Rd and River Rd in Crockett County. The Point of Interconnection is located at the dead-end structure in the Substation, where the jumper conductors from the Substation equipment physically contact the connectors on the Company's 69 kV transmission line conductors from Company's Cactus tap ("Cactus").
3. **Delivery Voltage:** 69 kV
4. **Metered Voltage:** 12.5 kV
5. **Loss Adjustment Due To Meter Location:** Yes
6. **Normal Operation of Interconnection:** Closed
7. **One-Line Diagram Attached:** Yes
8. **Facilities Ownership Responsibilities of the Parties:**
 - A. **Company owns the following facilities:**
 - i. the Cactus tap structure with three (3) switches in the Ft Lancaster to West Yates 69 kV transmission line
 - ii. the Ft Lancaster to West Yates 69 kV transmission line
 - iii. approximately 4300 feet of 69 kV transmission line from Cactus to the Substation dead-end structure
 - iv. meter and associated meter equipment on the load side of the Substation transformer.
 - B. **Cooperative owns the following facilities:**
 - i. all facilities within the Substation, except Company's meter and associated meter equipment provided hereinabove
9. **Operational Responsibilities of Each Party:**

Each party will operate the facilities it owns
10. **Maintenance Responsibilities of Each Party:**

Each Party will maintain the facilities it owns at its own expense
11. **Estimated Peak Load:** 6,232 kW
12. **Other Terms and Conditions:** None

FACILITY SCHEDULE NO. 24(continued)

Map of Area

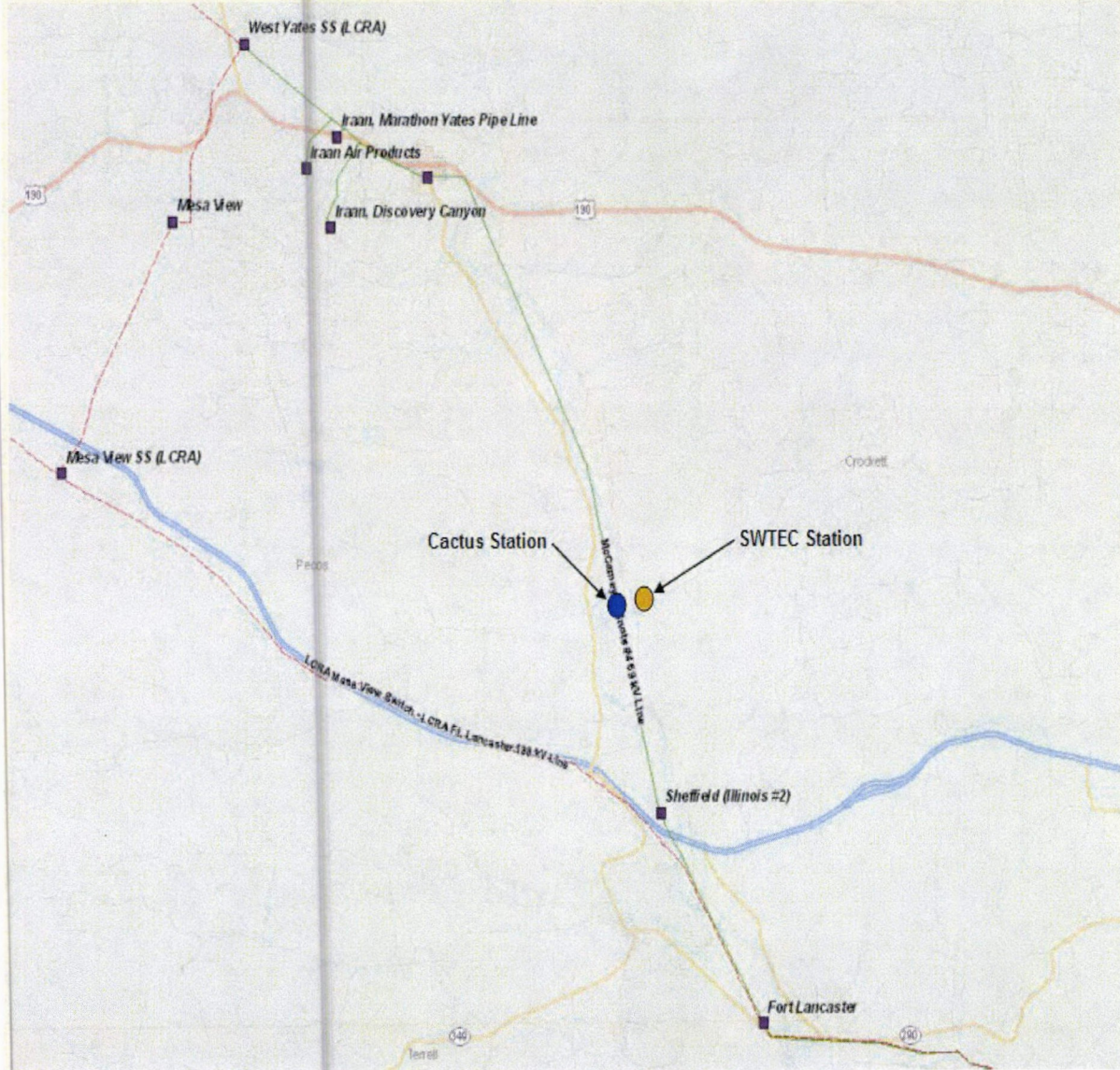

FACILITY SCHEDULE NO. 24 (continued)
One-Line Diagram

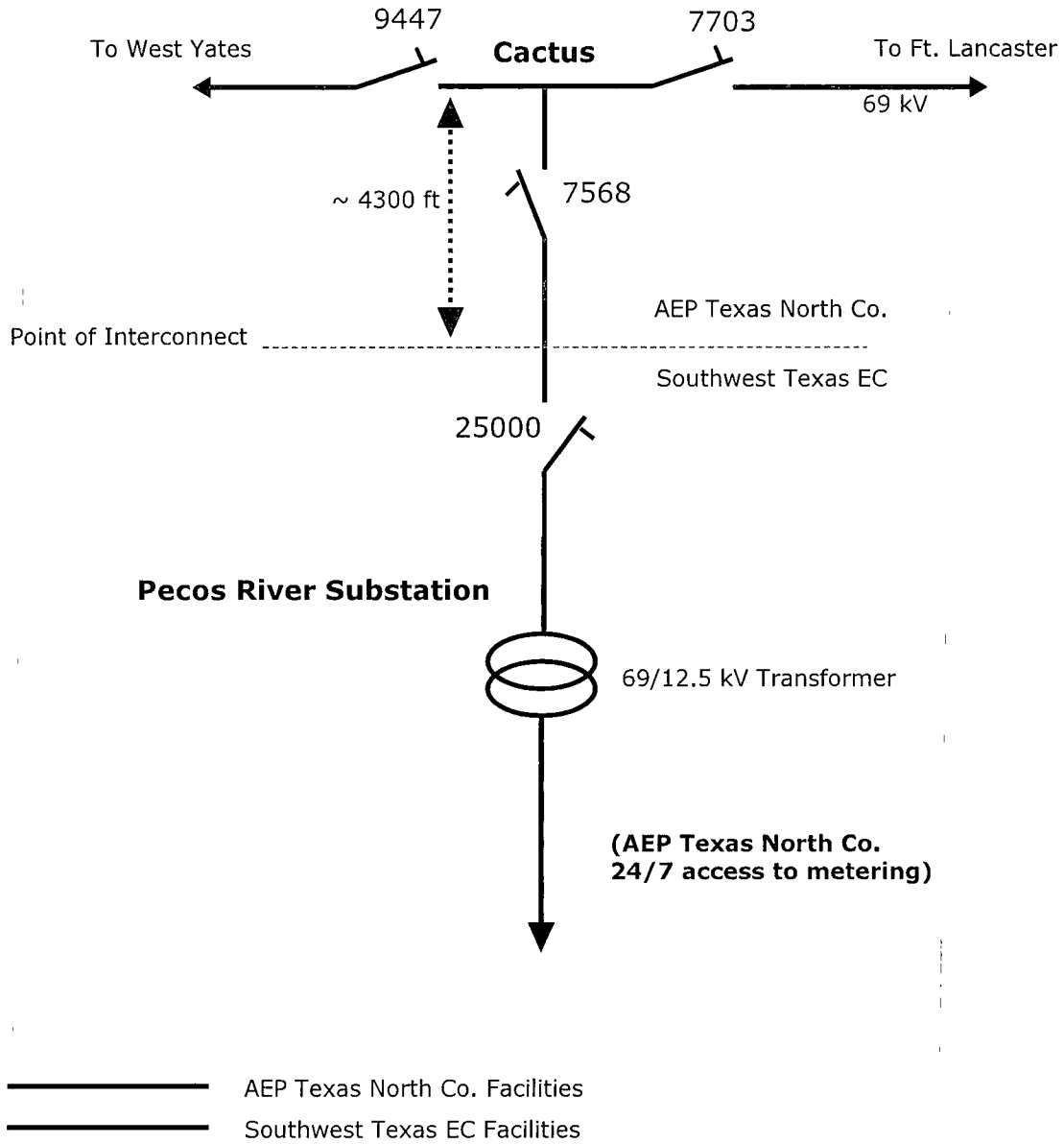

FACILITY SCHEDULE NO. 26

- 1. **Name:** Northern Natural Line
- 2. **Facility Location:** The Point of Interconnection (“POI”) is approximately 13.5 miles northwest of Eldorado, Texas, in Schleicher County. More specifically, the POI is where Company’s jumpers physically connect to the Cooperative’s primary conductors terminating on the tap pole.
- 3. **Delivery Voltage:** 12.5 kV
- 4. **Metering Voltage:** 12.5 kV
- 5. **Loss Adjustment Due To Meter Location:** None
- 6. **Normal Operation of Interconnection:** Closed
- 7. **One-Line Diagram Attached:** Yes
- 8. **Facilities Ownership Responsibilities of the Parties:**
 - A. **Company owns the following facilities:**
 - i. 12.5 kV distribution feeder including all facilities the distribution feeder needs to accommodate and serve the POI
 - ii. the meter pole
 - iii. the metering facilities
 - iv. the tap pole
 - B. **Cooperative owns the following facilities:**
 - ii. the facilities on the load-side of the tap pole
 - iii. overcurrent devices at the POI
 - iv. SCADA meter in series/parallel with the Company CTs/PTs
- 9. **Facility Operation Responsibilities of the Parties:**

Each Party will operate the facilities it owns.
- 10. **Facility Maintenance Responsibilities of the Parties:**



Each Party will maintain the equipment it owns at its expense.
- 11. **Estimated Peak Load:** 900 kW
- 12. **Other Terms and Conditions:** None

[The remainder of this page intentionally left blank]

FACILITY SCHEDULE NO. 26 (continued)

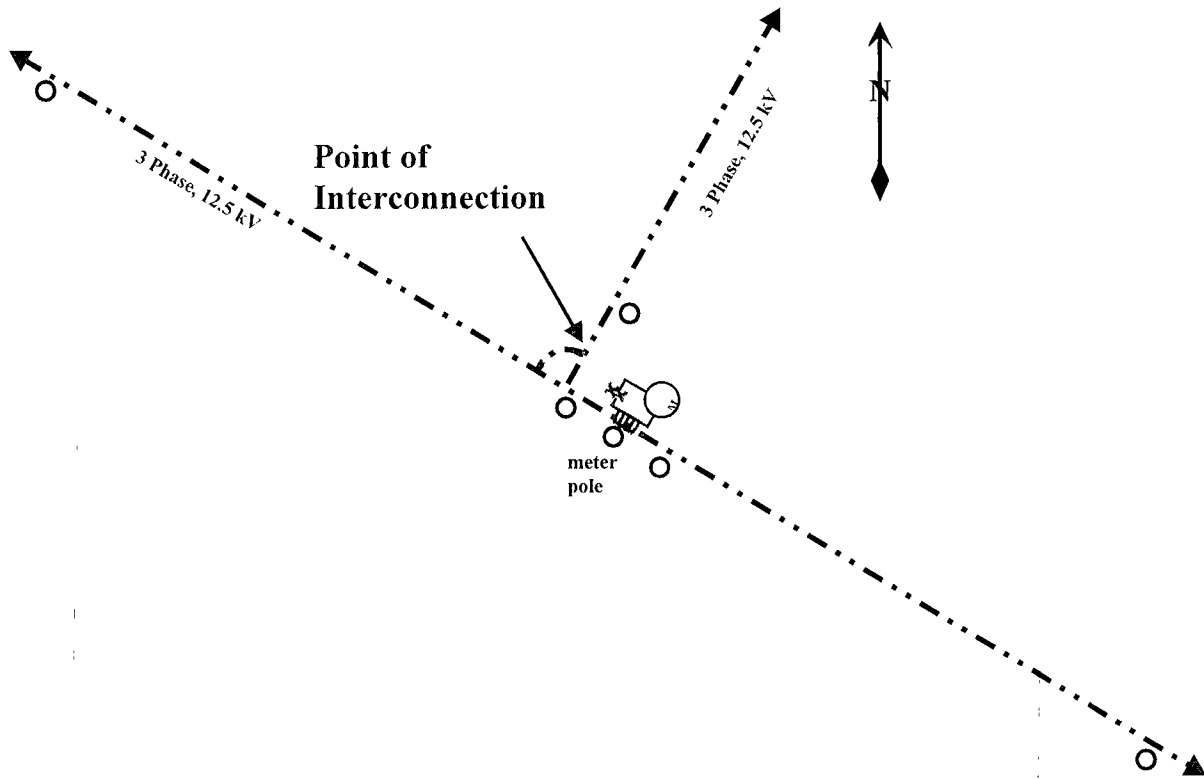
Conceptual One-line Drawing of Point of Interconnect



Company 
SWTEC 

Conceptual Drawing
Not to scale

FACILITY SCHEDULE NO. 27

1. **Name:** Yucca
2. **Facility Location:** The Point of Interconnection (“POI”) (30° 59’ 26.70” N., 101° 04’ 37.704” W.), is located in Crockett County, Texas, within the Company’s Yucca Substation (“Substation”). More specifically, the POI is where Company’s jumpers from the meter pole physically connect to the Cooperative’s primary conductors terminating on the meter pole.
3. **Delivery Voltage:** 12.5 kV
4. **Metering Voltage:** 12.5 kV
5. **Loss Adjustment Due To Meter Location:** None
6. **Normal Operation of Interconnection:** Closed
7. **One-Line Diagram Attached:** Yes
8. **Facilities Ownership Responsibilities of the Parties:**
 - A. **Company owns the following facilities:**
 - i. the Substation and all the facilities within it
 - ii. the meter pole outside the Substation
 - iii. the metering facilities
 - iv. the jumpers from the meter pole
 - B. **Cooperative owns the following facilities:**
 - i. the facilities on the load-side of the meter pole
 - ii. overcurrent devices at the POI
 - iii. SCADA meter in series/parallel with the Company CTs/PTs
9. **Facility Operation Responsibilities of the Parties:**

Each Party will operate the facilities it owns.
10. **Facility Maintenance Responsibilities of the Parties:**

Each Party will maintain the equipment it owns at its expense.
11. **Estimated Peak Load:** 4000 kW
12. **Other Terms and Conditions:**

Cooperative and Company will mutually agree on the coordination of the overcurrent devices provided by Cooperative at the POI.

FACILITY SCHEDULE NO. 27 (continued)
One-Line Diagram

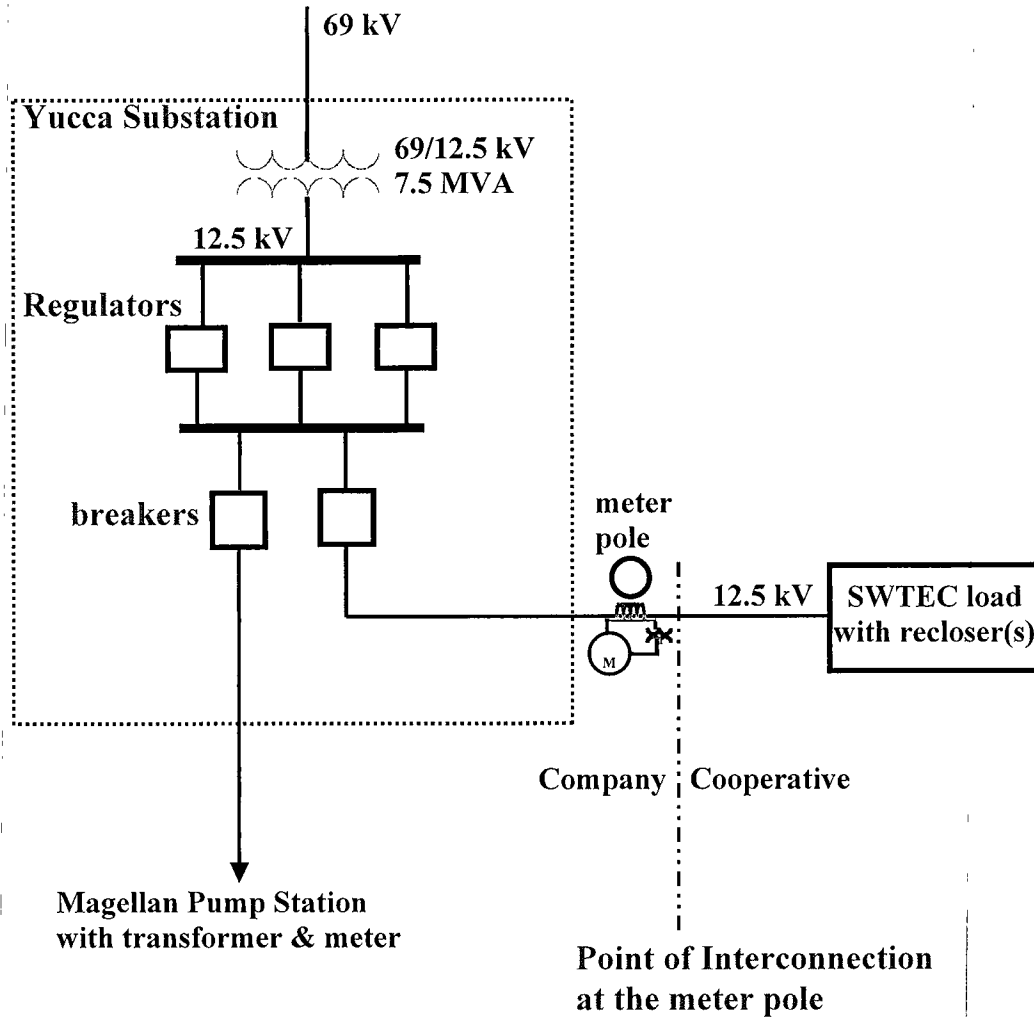

Conceptual Drawing
Not to scale

FACILITY SCHEDULE NO. 28

Flat Rock

TERMINATED

FACILITY SCHEDULE NO. 29

1. **Name:** **Rock Hollow**
2. **Facility Location:** The Point of Interconnection (“POI”) is located approximately 9.7 miles northeast of Company’s Big Lake substation, in Reagan County, Texas. More specifically, the POI is at Cooperative’s first structure outside of the Company’s 138 kV box bay Jerry Substation (“Substation”) with Company owning the single span of conductors back to the Substation, and Cooperative owning the structure and remaining conductors to Cooperative’s distribution substation approximately 150 feet from the Substation.
3. **Delivery Voltage:** 138 kV
4. **Metering Voltage:** 24.9 kV
5. **Loss Adjustment Due To Meter Location:** Yes
6. **Normal Operation of Interconnection:** Closed
7. **One-Line Diagram Attached:** Yes
8. **Facilities Ownership and Installation Responsibilities of the Parties:**
 - A. **Company will install and own the following facilities:**
 - i. the Substation and all associated facilities, including but not limited to the in-line and radial switches, Substation structures and property, and the first radial span of conductor out of the Substation
 - ii. the 14.4 kV metering facilities
 - B. **Cooperative will install and own the following facilities:**
 - i. the first structure outside of Substation and remaining facilities to Cooperative’s distribution substation
 - ii. isolating protective device within 2 spans of the 138 kV POI
 - iii. SCADA meter in series/parallel with the Company CT’s/PT’s
9. **Facility Operation Responsibilities of the Parties:**

Each Party will operate the facilities it owns.
10. **Facility Maintenance Responsibilities of the Parties:**

Each Party will maintain the equipment it owns at its own expense.
11. **Estimated Peak Load:** 15,000 kW
12. **Other Terms and Conditions:**

Parties mutually agree that this Facility Schedule may be amended to accurately document the

final as-built design of the installed permanent interconnection facilities.

FACILITY SCHEDULE NO. 29 (continued)

Area Map

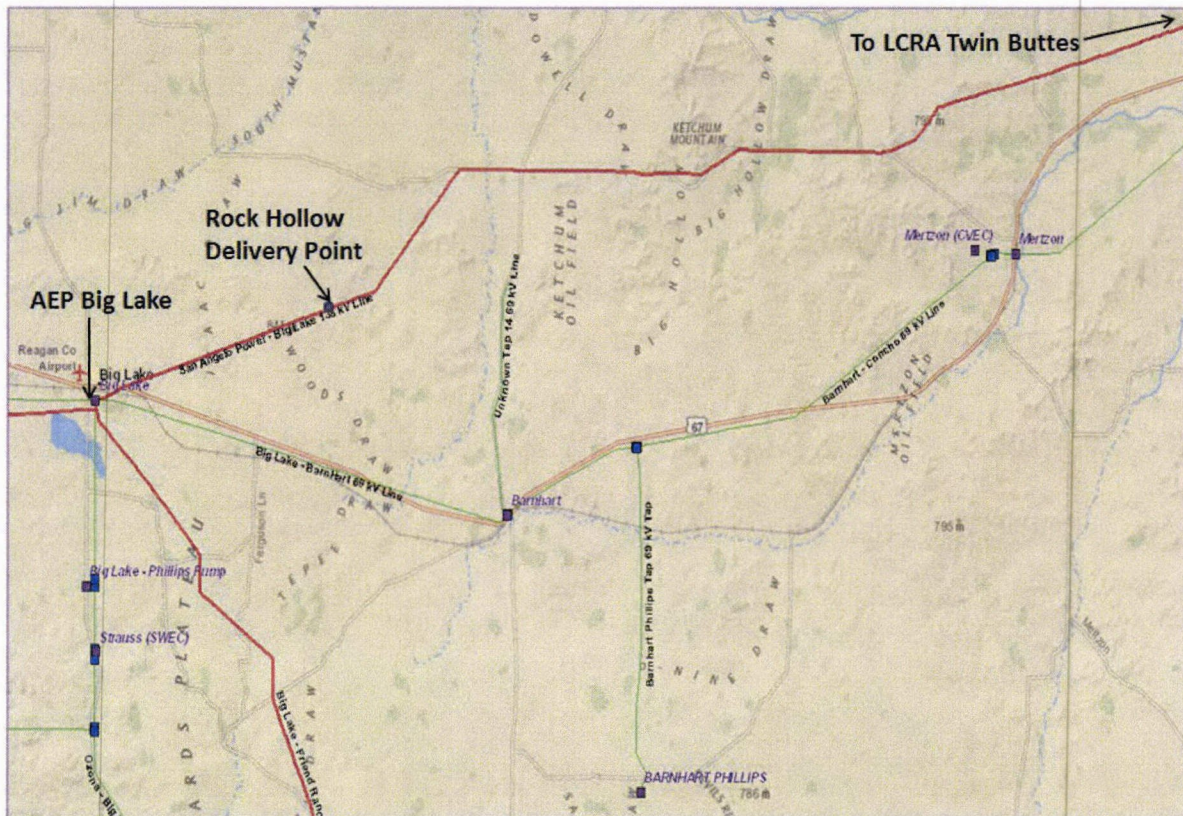

FACILITY SCHEDULE NO. 29(continued) One Line Diagram

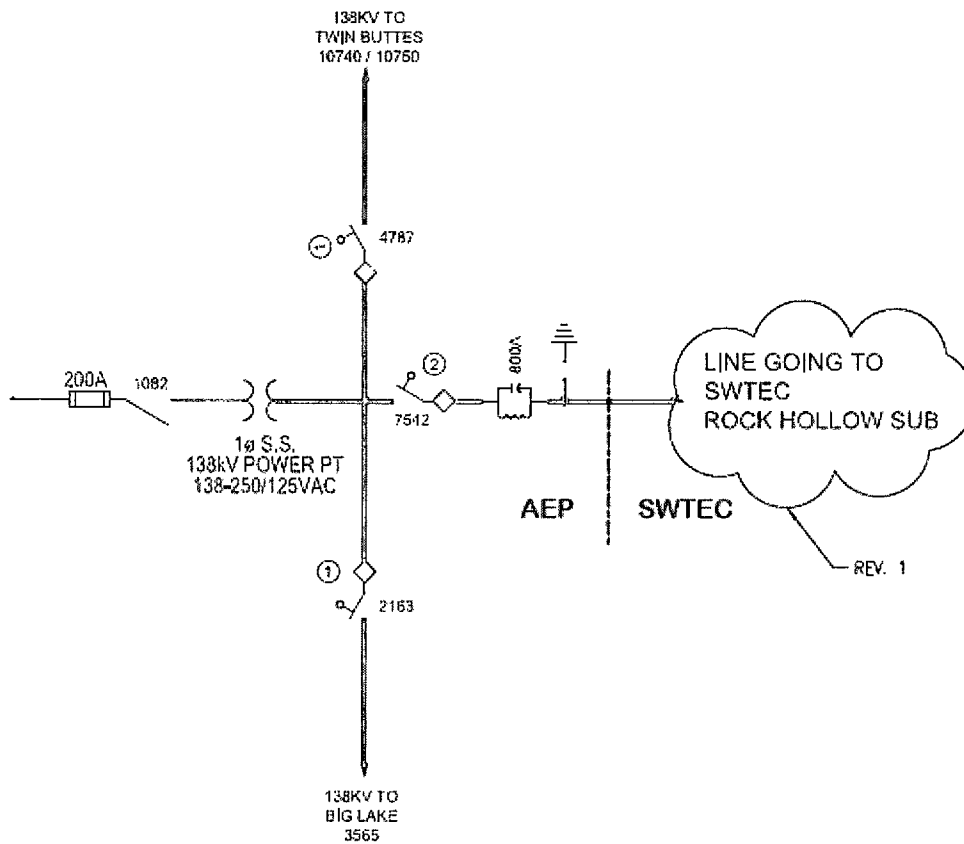

① VERTICAL BREAK, SLANTED V, COAB, MOTOR OPERATOR, ARCING HORNS, SF6 INTERRUPTER

TEXAS NORTH COMPANY		JERRY SUBSTATION # 498		138KV	
APP'D BY : BG	DR. BY : MED	CH. BY :	DATE : 08-29-13	ONE LINE DIAGRAM	
 1 RIVERSIDE PLAZA COLUMBUS, OH 43215		Work Order #:			
		42000000		DWG. No. W498SO01	REV 1

FACILITY SCHEDULE NO. 30

1. **Name:** Pandale
2. **Facility Location:** The Point of Interconnection (“POI”) (30° 41’ 19.97” N., 101° 16’ 12.0” W.), is located approximately two (2) miles west of Ozona, Texas, in Crockett County. More specifically, the POI is where Company’s jumpers from the meter pole physically connect to the SWTEC’s primary conductors terminating on the meter pole.
3. **Delivery Voltage:** 12.5 kV
4. **Metering Voltage:** 12.5 kV
5. **Loss Adjustment Due To Meter Location:** None
6. **Normal Operation of Interconnection:** Closed
7. **One-Line Diagram Attached:** Yes
8. **Facilities Ownership Responsibilities of the Parties:**
 - A. **Company owns the following facilities:**
 - i. the Pandale, 3-phase distribution feeder
 - ii. the meter pole
 - iii. the metering facilities
 - iv. the jumpers from the meter pole
 - B. **SWTEC owns the following facilities:**
 - i. the facilities on the load-side of the meter pole
 - ii. overcurrent devices at the POI
 - iii. SCADA meter in series/parallel with the Company CT’s/PT’s
9. **Facility Operation Responsibilities of the Parties:**

Each Party will operate the facilities it owns.
10. **Facility Maintenance Responsibilities of the Parties:**

Each Party will maintain the facilities it owns at its own expense.
11. **Estimated Peak Load:** 1,500 kW
12. **Other Terms and Conditions:**

Parties will mutually agree on the coordination of the overcurrent devices provided by SWTEC at the POI.

[The remainder of this page intentionally left blank]

FACILITY SCHEDULE NO. 30 (continued)

Conceptual One-line Drawing of Point of Interconnect

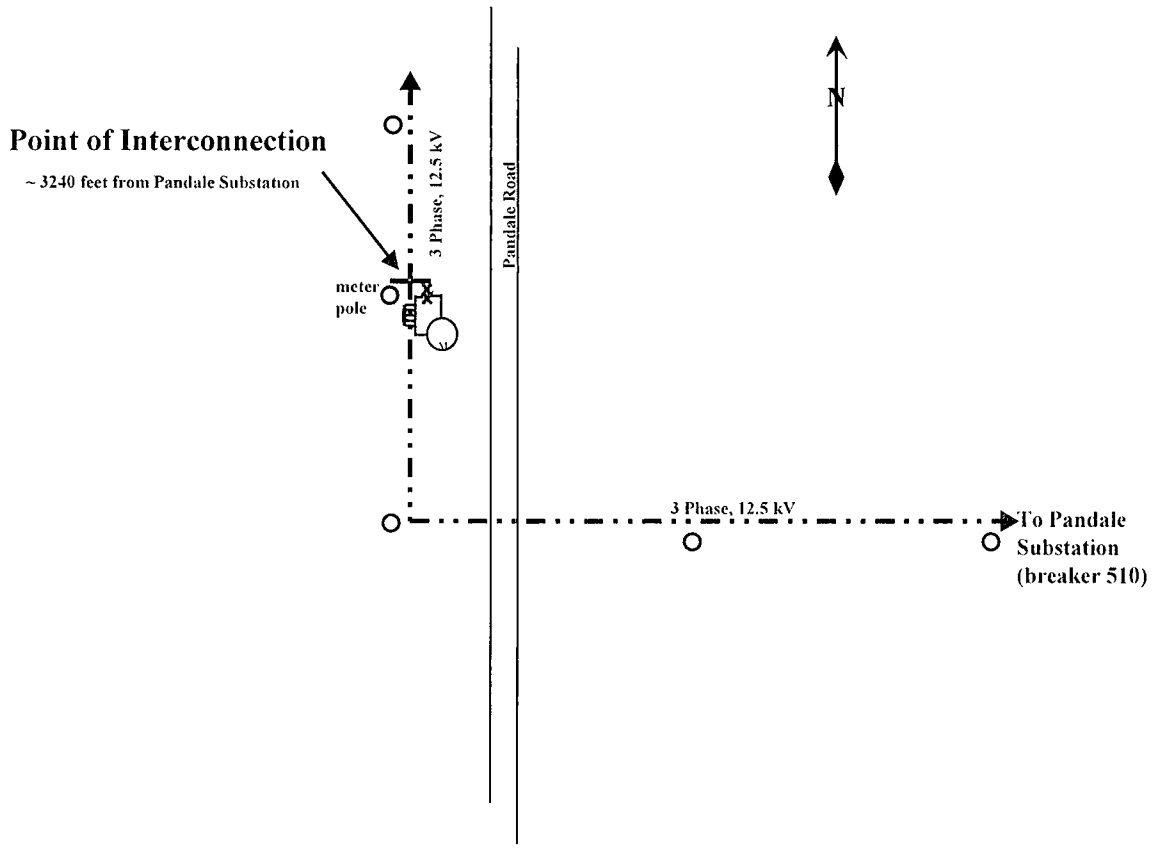

Company
SWTEC

Conceptual Drawing
Not to scale

FACILITY SCHEDULE NO. 31

1. **Name:** Trinity Field
2. **Facility Location:** The Point of Interconnection (“POI”) (31° 05’ 05.93” N., 101° 37’ 20.18” W.), is located approximately 3.1 miles east of Ranch Road 1676, in Crockett County Texas. More specifically, the POI is where AEP’s jumpers from the meter pole physically connect to the SWTEC’s primary conductors terminating on the meter pole.
3. **Delivery Voltage:** 12.5 kV
4. **Metering Voltage:** 12.5 kV
5. **Loss Adjustment Due To Meter Location:** None
6. **Normal Operation of Interconnection:** Closed
7. **One-Line Diagram Attached:** Yes
8. **Facilities Ownership Responsibilities of the Parties:**
 - A. **AEP owns the following facilities:**
 - i. the Powell Field, 3-phase distribution feeder (circuit 2529)
 - ii. the meter pole
 - iii. the metering facilities
 - iv. the jumpers from the meter pole
 - B. **SWTEC owns the following facilities:**
 - i. the facilities on the load-side of the meter pole
 - ii. overcurrent devices at the POI
 - iii. SCADA meter in series/parallel with the AEP CT’s/PT’s
9. **Facility Operation Responsibilities of the Parties:**

Each Party will operate the facilities it owns.
10. **Facility Maintenance Responsibilities of the Parties:**

Each Party will maintain the facilities it owns at its own expense.
11. **Estimated Peak Load:** 1,600 kW
12. **Other Terms and Conditions:**
 - A. Parties will mutually agree on the coordination of the overcurrent devices provided by SWTEC at the POI.
 - B. Parties mutually agree that this Facility Schedule may be amended to accurately document the final as-built design of the installed interconnection facilities

FACILITY SCHEDULE NO. 31 (continued)
One Line Diagram

Conceptual Drawing
Not to scale

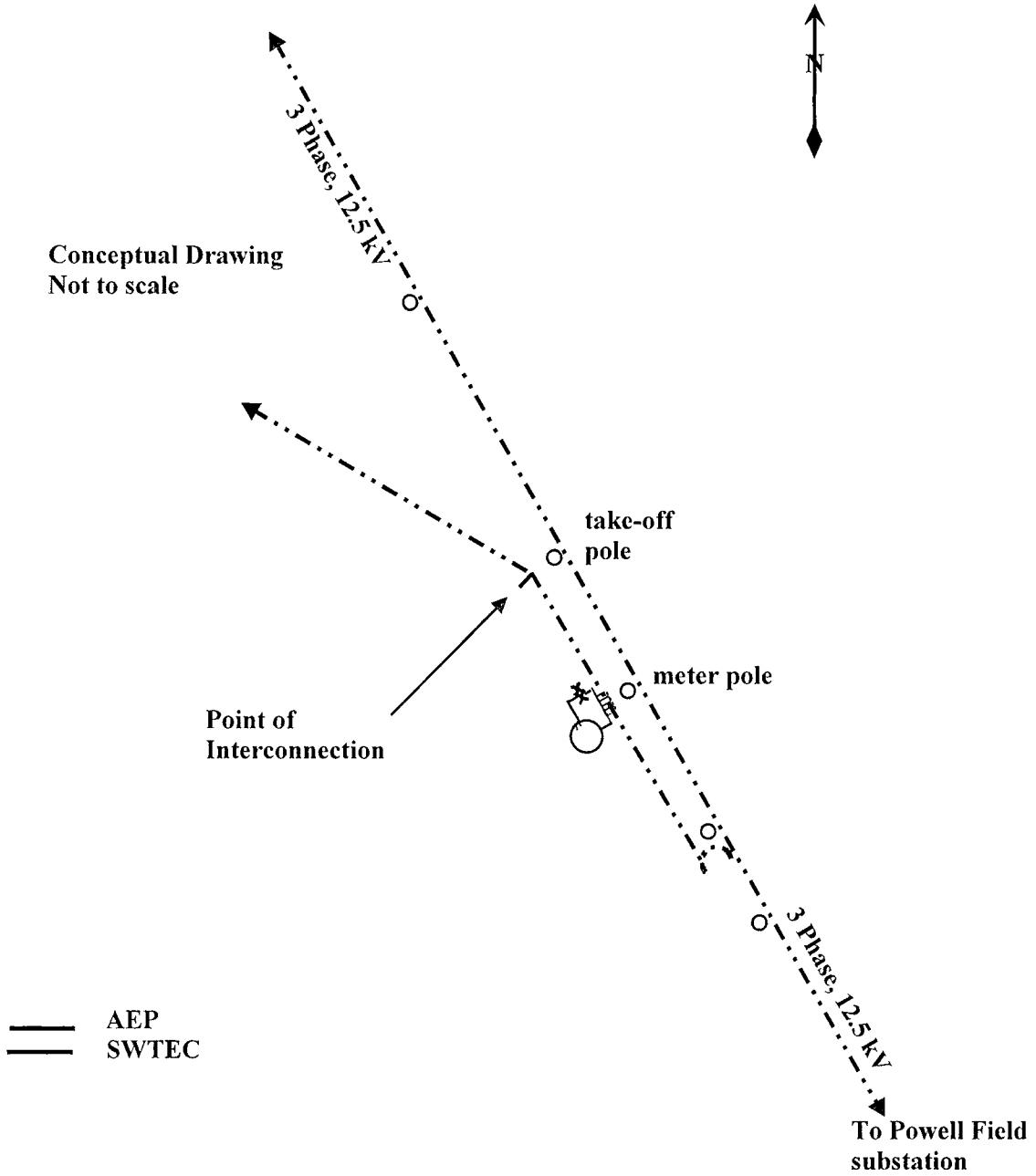

FACILITY SCHEDULE NO. 32

1. **Name:** **Pave Paws**
2. **Facility Location:** The Pave Paws Point of Interconnection (“POI”) (31° 00’ 17.67” N., 100° 33’ 19.51” W.), is located in Schleicher County, on the northeast corner of where County Road 303 and County Road 312 intersect, approximately 10.4 miles north of Eldorado, Texas. The POI is where AEP’s slack-span conductors from the Live Oak to Concho 69 kV transmission line terminate on the dead-end structure within the Pave Paws substation. More specifically, the POI is where SWTEC’s jumper conductors from the Pave Paws substation disconnect switch (2777) physically connect to AEP’s slack-span conductors terminating on the dead-end structure.
3. **Delivery Voltage:** 69 kV
4. **Metering Voltage:** 69 kV
5. **Loss Adjustment Due To Meter Location:** None
6. **Normal Operation of Interconnection:** Closed
7. **One-Line Diagram Attached:** Yes
8. **Facilities Ownership Responsibilities of the Parties:**
 - A. **AEP owns the following facilities:**
 - i. the Live Oak to Concho 69 kV transmission line
 - ii. the slack-span conductors
 - B. **SWTEC owns the following facilities:**
 - i. the dead-end within the Pave Paws substation
 - ii. the disconnect switch (2777)
 - iii. the 69 kV meters and metering facilities
9. **Facility Operation Responsibilities of the Parties:**
Each Party will operate the facilities it owns.
10. **Facility Maintenance Responsibilities of the Parties:**
Each Party will maintain the facilities it owns at its own expense.
13. **Estimated Peak Load:** N/A kW
14. **Other Terms and Conditions:**
 - A. Parties will mutually agree on the coordination of the overcurrent devices provided by SWTEC at the POI.
 - B. Parties mutually agree that this Facility Schedule may be amended to accurately document the final as-built design of the installed interconnection facilities

FACILITY SCHEDULE NO. 32 (continued)
One Line Diagram

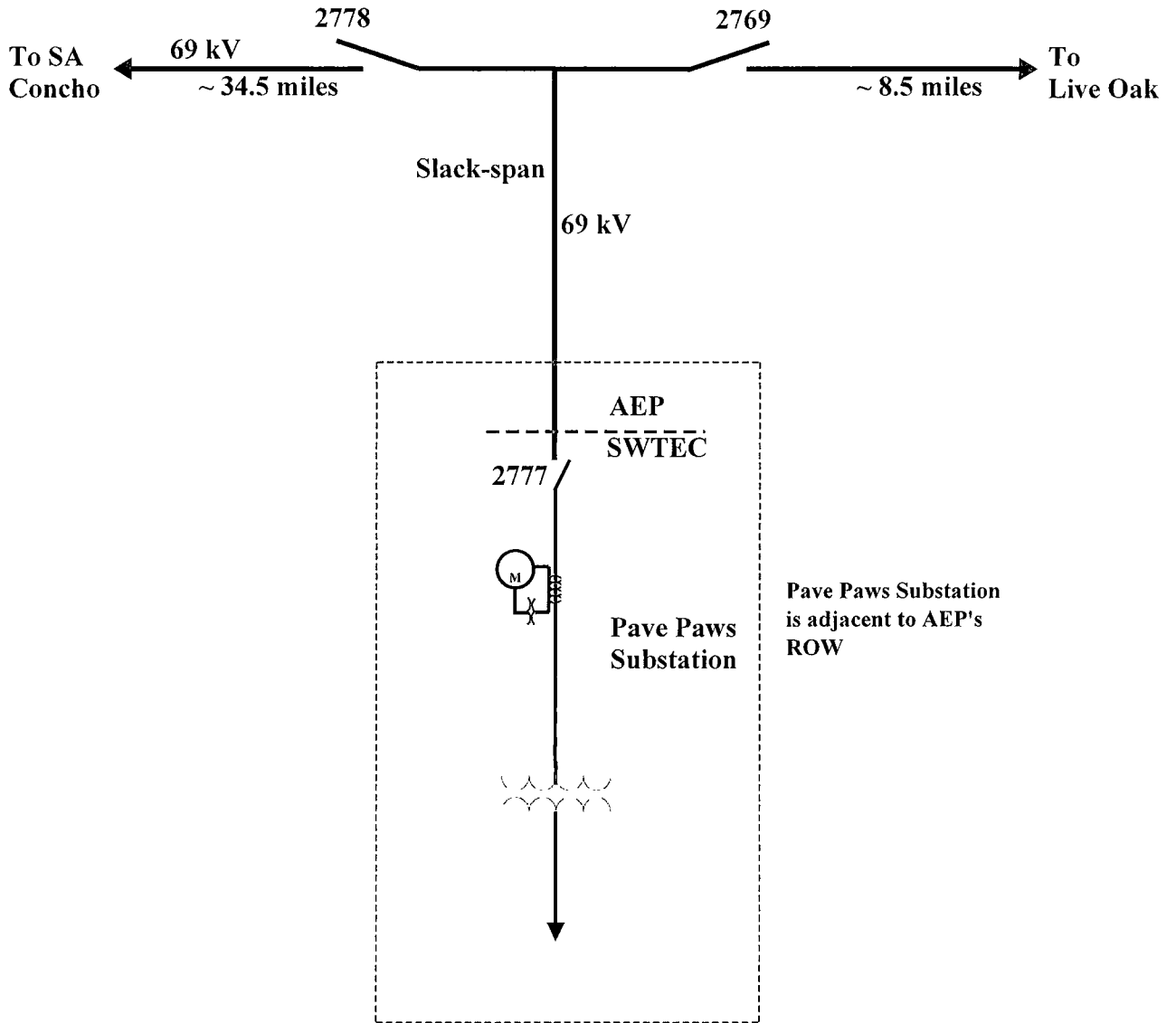

———— AEP
———— SWTEC

Distances as shown are conceptual and not to scale;
facilities are not shown completely.

FACILITY SCHEDULE NO. 33

- 1. Name:** **Martin**
- 2. Facility Location:** AEP’s Wolfcamp Station (“AEP Station”) is located approximately twenty (20.0) mile west of Big Lake, Texas, and four (4.0) miles south of US Hwy 67 in Upton County in the North McCamey to Big Lake 138 kV transmission line right of way. The Point of Interconnection will be located on the AEP Station dead-end structure at the AEP Station. More specifically, the Point of Interconnection is located where the jumper conductors from the AEP Station equipment connect to SWTEC’s 138 kV transmission line conductors from SWTEC’s Martin Substation (“Substation”).
- 3. Delivery Voltage:** 138 kV
- 4. Metering Voltage:** 12.5 kV
- 5. Loss Adjustment Due To Meter Location:** Yes
- 6. Normal Operation of Interconnection:** Closed
- 7. One-Line Diagram Attached:** Yes
- 8. Facilities Ownership and Installation Responsibilities of the Parties:**
 - A. AEP will install and own the following facilities:**
 - i. the North McCamey to Big Lake 138 kV (existing) transmission line
 - ii. the AEP Station and all associated facilities, including but not limited to the in-line and radial switches
 - iii. 12.5 kV metering and metering facilities in series/parallel with the SWTEC’s CT’s/PT’s
 - iv. the 138 kV jumpers at the AEP Station
 - v. remote terminal unit
 - vi. wavetrap
 - B. SWTEC will install and own the following facilities:**
 - i. the Substation and all associated facilities
 - ii. 12.5 kV meters and metering facilities within the Substation
 - iii. the 138 kV transmission slack span from the Substation to AEP’s Station
- 9. Facility Operation Responsibilities of the Parties:**

Each Party will operate the facilities it owns.
- 10. Facility Maintenance Responsibilities of the Parties:**

Each Party will maintain the equipment it owns at its own expense.

11. Estimated Peak Load: 10,000 kW

12. Other Terms and Conditions:

- A. The Parties recognize that AEP is installing the facilities described in Section 8A hereinabove to facilitate GSEC's request for a new Point of Interconnection to be provided by this Agreement. If GSEC cancels its request for this Point of Interconnection GSEC agrees to pay AEP for the costs that it has incurred (including the temporary facilities costs described in Section 12(C), below) in accordance with Section 4.11 or 4.12 of the Agreement. In the event such payment is determined to be taxable income to AEP and subject to income tax or franchise tax, GSEC shall reimburse AEP for the tax effect of such payment. AEP and GSEC shall cooperate in good faith concerning the determination of the tax effect of such payment. AEP's estimated total installed cost of its facilities is Two Million One Hundred Thousand Dollars (\$2,100,000)
- B. AEP's in-service date for the Point of Interconnection is estimated to be twenty-four (24) months from the Execution Date of this Agreement. AEP will use reasonable efforts to provide the Point of Interconnection on the desired in-service date in accordance with, and subject to the terms of, Section 4.5(a) of the Agreement.
- C. In the event AEP reasonably expects that it will not be able to complete the Point of Interconnection by the requested in-service date, AEP will promptly provide written notice to GSEC and will undertake reasonable efforts to meet the earliest date thereafter. At GSEC's request, AEP will also install the temporary facilities (temporary pole and hard tap conductors) necessary to energize the Point of Interconnection by the requested in-service date, and AEP will not directly assign to, or otherwise recover from, GSEC the costs it incurs in installing and removing those temporary facilities except as described in Section 12(A), above. The Parties will keep each other advised periodically as to the progress of their respective design, procurement, and construction efforts regarding the Point of Interconnection. If, at any time, GSEC becomes aware that the completion of the Point of Interconnection will not be required until after the requested in-service date, GSEC will promptly provide written notice to AEP of a new, later in-service date.
- D. Parties mutually agree that this Facility Schedule may be amended to accurately document the final as-built design of the installed permanent interconnection facilities.
- E. SWTEC will provide meter data to AEP, and if SWTEC determines read access by AEP to the meters is feasible, SWTEC will allow AEP to remotely poll the metering data from SWTEC's 12.5 kV metering facilities while in the temporary facilities configuration until installation of the permanent facilities, if applicable.

FACILITY SCHEDULE NO. 33 (continued)

Area Map

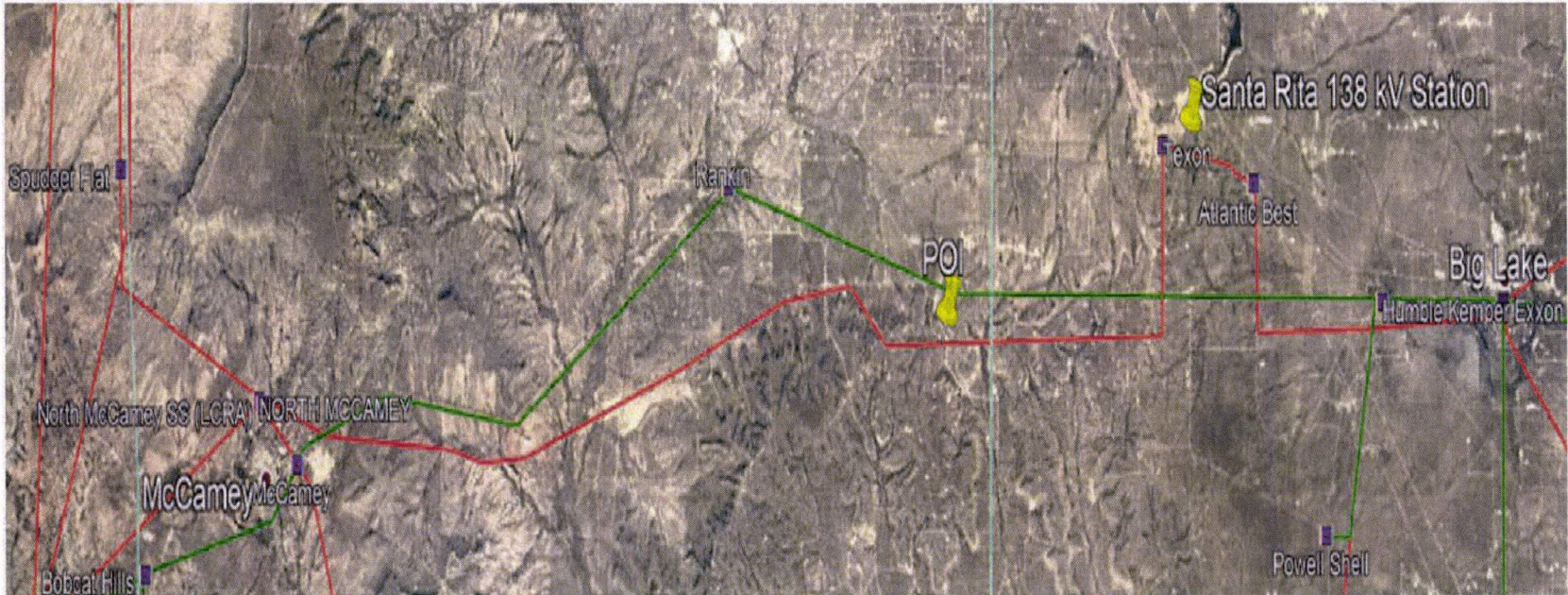

FACILITY SCHEDULE NO. 33(continued)
One Line Diagram

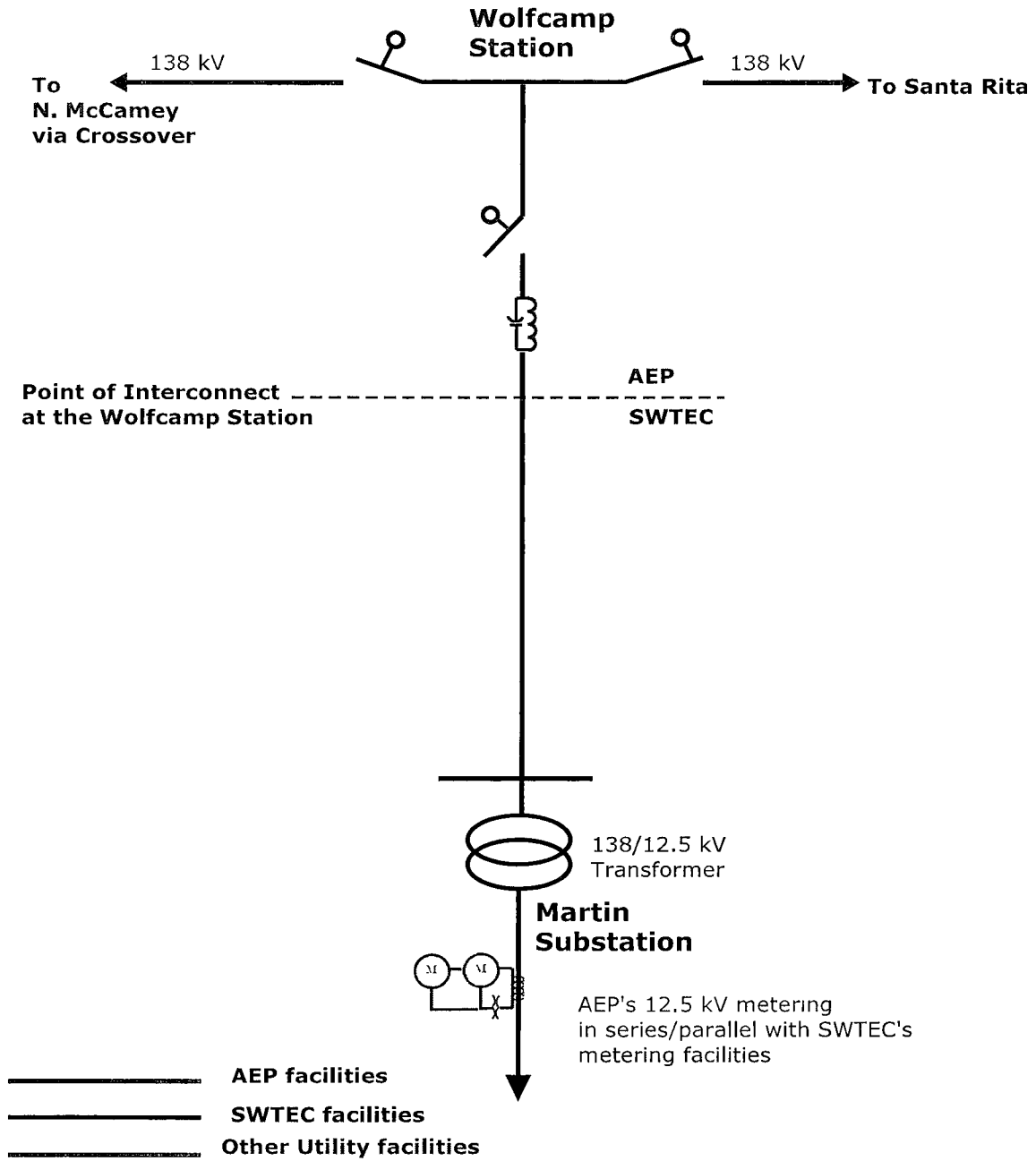

Distances as shown are conceptual and not to scale;
facilities are not shown completely.